	<b>TECHNICAL SPECIFICATION</b>		Nº: <b>I-ET-0000.00-0000-274-P9U-001</b>
	CLIENT:	GENERAL	SHEET: 1 de 72
	JOB:	GENERAL	-
	AREA:	GENERAL	-
-	TITLE:	<b>SLWR DETAILED STRUCTURAL DESIGN REQUIREMENTS</b>	EDR
-	-	-	-

**INDEX OF REVISIONS**

REV.	DESCRIPTION AND/OR REVISED SHEETS
0	ORIGINAL (THIS DOCUMENT SUPERSEDES THE DOCUMENT I-ET-0000.00-6500-274-P9U-001)
A	ITENS 4.4 AND 6.4.3
B	SOIL EMBEDMENT (ITEMS 6-I, 7.1-K, 7.2.1-M); TABLE 6 (ALS3A AND B); REFERENCE [13]
C	GENERAL REVISIONS
D	GENERAL REVISIONS
E	GENERAL REVISIONS
F	GENERAL REVISIONS
G	GENERAL REVISIONS
<b>H</b>	<b>GENERAL REVISIONS</b>

	REV. 0	REV. A	REV. B	REV. C	REV. D	REV. E	REV. F	REV. G	REV. H
DATE	28/DEC/2017	16/FEB/2018	13/MAR/2018	19/AUG/2020	07/MAY/2021	13/OCT/2022	19/JUL/2023	10/MAY/2024	31/OCT/2024
EXECUTION	BXT4	BXT4	BXT4	BXT4	BXT4	BXT4	BXT4	BXT4	BXT4
CHECK	TS8H	TS8H	TS8H	TS8H	TS8H	TS8H/ BTTB	TS8H/ ER46	C5DL/ BTTB	C5DL/BTTB
APPROVAL	CLZ2	CLZ2	CLZ2	CLZ2	CLZ2	CLZ2	CLZ2	BF6J	BF6J

THE INFORMATION CONTAINED IN THIS DOCUMENT IS PETROBRAS' PROPERTY AND MAY NOT BE USED FOR PURPOSES OTHER THAN THOSE SPECIFICALLY INDICATED HEREIN.  
THIS FORM IS PART OF PETROBRAS' N-381-REV.M.



<b>TECHNICAL SPECIFICATION</b>	Nº: <b>I-ET-0000.00-0000-274-P9U-001</b>	REV. <b>H</b>
<b>GENERAL</b>		SHEET: <b>2 de 72</b>
TITLE: <b>SLWR DETAILED STRUCTURAL DESIGN REQUIREMENTS</b>		<b>EDR</b>
		<b>-</b>

## TABLE OF CONTENTS

<b>DEFINITIONS.....</b>	<b>4</b>
<b>1. INTRODUCTION.....</b>	<b>7</b>
1.1. OBJECTIVE .....	7
1.2. SCOPE OF WORK .....	7
1.3. TYPICAL SLWR CONFIGURATION .....	8
<b>2. DESIGN ANALYSIS REQUIREMENTS .....</b>	<b>9</b>
<b>3. DESIGN DATA DEFINITION .....</b>	<b>11</b>
<b>4. STRUCTURAL GLOBAL MODEL DEFINITION .....</b>	<b>16</b>
4.1. FINITE ELEMENT MODEL.....	16
4.2. WALL THICKNESS .....	16
4.3. CLAD AND LINED PIPES .....	16
4.4. FLEXIBLE JOINT MODELING .....	17
4.5. STRESS-JOINT MODELING .....	18
4.6. TITANIUM PULL IN TUBE MODELING .....	19
4.7. SOIL MODEL.....	19
4.8. MORISON COEFFICIENTS .....	20
4.9. ANALYSIS SOFTWARE.....	20
4.10. GENERAL REQUIREMENTS.....	20
<b>5. EXTREME COMBINED LOAD EFFECT ANALYSIS .....</b>	<b>21</b>
5.1. LOAD COMBINATIONS FOR ULS AND ALS.....	23
5.2. LOADING CASES .....	25
5.2.1. FOR SMS FPU .....	26
5.2.2. FOR SPM FPU .....	27
5.3. WAVE SCREENING.....	28
5.4. SIMULATION OF IMPOSED MOTIONS AND WAVES .....	31
5.4.1. EQUIVALENT HARMONIC MOTION PROCEDURE (EHMP).....	32
5.4.2. IRREGULAR WAVE PROCEDURE (IWP).....	32
5.5. SENSITIVITY ANALYSES.....	33
<b>5.6. LIMIT OFFSET FOR 1<sup>ST</sup> RISERS PULL-IN .....</b>	<b>34</b>
<b>6. FATIGUE ANALYSIS .....</b>	<b>35</b>
6.1. WAVE AND MOTION FATIGUE ANALYSIS.....	38
6.1.1. METHODOLOGY REQUIREMENTS .....	38
6.1.2. LOADING CASES .....	39
6.1.3. SENSITIVITY ANALYSIS .....	40
6.2. VIV FATIGUE ANALYSIS.....	42
6.2.1. CURRENT VIV FATIGUE ANALYSIS.....	42
6.2.2. HEAVE INDUCED VIV FATIGUE ANALYSIS.....	44
6.2.3. SENSITIVITY ANALYSIS .....	44



<b>TECHNICAL SPECIFICATION</b>	Nº: <b>I-ET-0000.00-0000-274-P9U-001</b>	REV. <b>H</b>
<b>GENERAL</b>		SHEET: <b>3 de 72</b>
TITLE: <b>SLWR DETAILED STRUCTURAL DESIGN REQUIREMENTS</b>		<b>EDR</b>
		<b>-</b>

6.3. SLUGGING EFFECT ANALYSIS .....	45
6.3.1. SENSITIVITY ANALYSIS .....	46
<b>7. INTERFACE LOADS .....</b>	<b>47</b>
7.1. TOP INTERFACE LOADS.....	47
7.1.1. TOP LOADS BY EXTREME LOADING ANALYSIS.....	48
7.1.2. TOP LOADS BY WAVE AND MOTION ANALYSIS.....	50
7.2. BOTTOM INTERFACE LOADS.....	51
<b>8. INTERFERENCE ANALYSIS .....</b>	<b>51</b>
<b>9. INSTALLATION ANALYSIS.....</b>	<b>51</b>
<b>10. DELIVERABLES .....</b>	<b>52</b>
10.1. GENERAL DELIVERABLES .....	53
10.1.1. <b>RISER</b> DESIGN BASIS REPORT .....	53
10.1.2. <b>RISER</b> DESIGN PREMISES AND METHODOLOGY REPORT .....	53
10.1.3. <b>RISER</b> DESIGN SUMMARY REPORT .....	53
10.2. SPECIFIC TOPIC DELIVERABLES .....	53
10.2.1. <b>RISER</b> EXTREME COMBINED LOAD EFFECT ANALYSIS REPORT .....	53
10.2.2. <b>RISER</b> TOP AND BOTTOM INTERFACE LOADS REPORT .....	55
10.2.3. <b>RISER</b> WAVE AND MOTION FATIGUE ANALYSIS REPORT .....	55
10.2.4. <b>RISER</b> VIV FATIGUE ANALYSIS REPORT .....	56
10.2.5. <b>RISER</b> SLUGGING ANALYSIS REPORT .....	57
10.2.6. <b>RISER</b> COMBINED FATIGUE ANALYSIS SUMMARY REPORT .....	58
<b>10.2.7. RISER EFFORTS AT MONITORING SYSTEM REPORT .....</b>	<b>59</b>
<b>11. REFERENCES.....</b>	<b>60</b>
<b>APPENDIX A FXJ STIFFNESS AS A FUNCTION OF THE ALTERNATING ANGLE ....</b>	<b>62</b>
<b>APPENDIX B RISER BOTTOM CURRENT PROFILE INTERPOLATION CRITERIA ....</b>	<b>66</b>
<b>APPENDIX C UPSET-END STRESSES.....</b>	<b>68</b>
<b>APPENDIX D VIV TDP SPREADING .....</b>	<b>70</b>



## DEFINITIONS

The following definitions are used for the purpose of this technical specification:

- ALS Accidental Limit State
- BE Best estimate
- BM Bending Moment
- C-Mn Carbon Manganese Steel
- CONTRACTOR The company responsible for the design of the risers and related equipment.
- CoR Center of Rotation (see Figure 7)
- CRA Corrosion Resistant Alloy
- CRA Pipes When referred herein, means clad pipes or lined pipes
- Fatigue sensitive Sections The fatigue sensitive riser sections will be the sections not classified as non-fatigue sensitive, according to Table 1 (item 5.19).
- **DAF** **Drag Amplification Factor**
- Design Life Operation, installation and decommissioning duration, as per [2].
- DNV Det Norske Veritas
- DNV UF DNV Usage Factor
- DOF Degree of Freedom
- ECA Engineering Critical Assessment
- EHMP Equivalent Harmonic Motion Procedure
- EOL End of Life
- ET Effective Tension
- FEA Finite Element Analysis
- FEM Finite Element Method
- FXJ Flexible Joint
- FPSO Floating, Production, Storage and Offloading Unit
- FPU Floating Production Unit
- HOA Hang-Off Adaptor
- Hs Wave Significant Height
- ID Inner wall
- ILA In Line Anchor
- KH Keel Hauling
- LRFD Load and Resistance Factor Design
- LE Lower Estimate
- LTSJ Lower Titanium Stress Joint

- Metocean Meteorological & Oceanographic
- movX, movY, movZ, FPU motions (translational and rotational) imposed at riser top  
movRX, connection, at FPU local reference system (see Figure 7).  
movRY, movRY
- NMP No Motion Point
- OD Outer wall
- PETROBRAS PETROBRAS - Petróleo Brasileiro S.A.
- PLET Pipeline End Terminal
- Project Scope of activities performed by the CONTRACTOR for a specific field and host FPU
- RAO Response Amplitude Operator
- RMS Root Mean Square
- SAG&HOG Regions of the SLWR configuration – See FIGURE 1
- SCF Stress Concentration Factor
- SCR Steel Catenary Riser
- SF Shear Force
- SJ Stress Joint (that can be built with steel or titanium material)
- SLWR Steel Lazy Wave Riser
- SMS Spread Moored System
- SMYS Specified Minimum Yield Stress
- SN curve Stress range versus number of cycles design curve
- SOL Start of Life
- SPM Single Point Moored (Turret System)
- SUPPLIER The organization that constructs the equipment or item referred to in the text, and provides it under a Purchase Order directly to the PETROBRAS or through the CONTRACTOR for riser EPCI
- Support-tube Generic term that refers to the tubular support type installed at the lower riser balcony. Support-Tubes can be I-Tube, BSMF, BSDL, RmoST and TSUDL. The specific Support type of the Project is defined in [2].
- SWL Still Water Level
- TBD To be defined
- TD Time Domain
- TDP Touch Down Point – Point on which the riser touches the soil



TITLE:

**SLWR DETAILED STRUCTURAL DESIGN REQUIREMENTS**

EDR

-

- TDZ Touch Down Zone – Zone of variation of TDP
- TiPT Titanium Pull-in Tube
- Top Riser Connector Generically refers to the equipment that promotes the connection of the riser to the platform, distributing the interface loading while allowing unimpeded passage of carried fluids. It may be Flexible joint, steel or titanium Stress Joint, Titanium Pull in Tube or other devices clearly specified within Project Documentation.
- ToT Top of Taper (see Figure 7)
- Tp Wave Peak Period
- TSJ Titanium Stress Joint
- UE Upper Estimate
- ULS Ultimate Limit State
- UTSJ Upper Titanium Stress Joint
- TRF Riser/Flowline Transition – Point considered as the transition between riser and flowline, based on a soil contact, without lateral and vertical displacements due to the riser dynamic along the design life
- VIM Vortex Induced Motion
- VIV Vortex Induced Vibration

Shall	Indicates a mandatory requirement
Should	Indicates a preferred course of action
May	Is used where alternatives are equally acceptable

	<b>TECHNICAL SPECIFICATION</b>	Nº: <b>I-ET-0000.00-0000-274-P9U-001</b>	REV. <b>H</b>
	<b>GENERAL</b>		SHEET: <b>7 de 72</b>
	TITLE: <b>SLWR DETAILED STRUCTURAL DESIGN REQUIREMENTS</b>		<b>EDR</b>
			-

## 1. INTRODUCTION

### 1.1. OBJECTIVE

The purposes of this Technical Specification are:

- To define the requirements for the analysis procedure to be employed;
- To establish the acceptance criteria to be employed in the Structural Detailed Design of the SLWR configurations;
- To define the deliverables minimum content and the standard to present the results.

### 1.2. SCOPE OF WORK

CONTRACTOR shall proceed to the complete structural verification of SLWR configurations. This work shall include all aspects related in this Specification and others that may be added as a function of the Codes or other recommendations, in order to guarantee that the riser is structurally safe for the intended design life under the operational, accidental, temporary and installation conditions.

Despite the identification of lines presented in [2], a complete set of steel risers shall be designed to be installed in any of the riser balcony supports designated for its function, regardless of the installation type (direct pull-in and KH). The results of all steel risers shall be documented.

The Detailed Design shall incorporate the **real characteristics** of the purchased equipment related to the riser construction, such as:

- Riser configuration definition;
- Buoyancy modules characteristics (material, dimensions, etc);
- Clad or lined pipe length and wall thickness;
- C-Mn pipe length and wall thickness;
- Pipe coating characteristics (material, dimensions, etc);
- FXJ/ SJ capacity in terms of angular deflection and tension;
- VIV suppressors characteristics (type, length, pitch, dimensions, etc).

Analyses that do not incorporate all final riser characteristics will be considered as preliminary and shall be reassessed to provide final results.

At the beginning of the riser design, prior to the start of the analyses, CONTRACTOR shall present templates of all documents required in section 10 to be issued, for discussion and evaluation by PETROBRAS. These templates shall cover the text body as well as corresponding attachments for the analyses results. It aims to minimize the number of reviews in each document, reducing the time for final approval of this set of riser detailed reports.

### 1.3. TYPICAL SLWR CONFIGURATION

SLWR – Compliant riser configuration with intermediate buoyancy sections designed to absorb most of FPU vertical motion, improving the riser response in the TDZ and avoiding critical stresses oscillations, as per Figure 1.

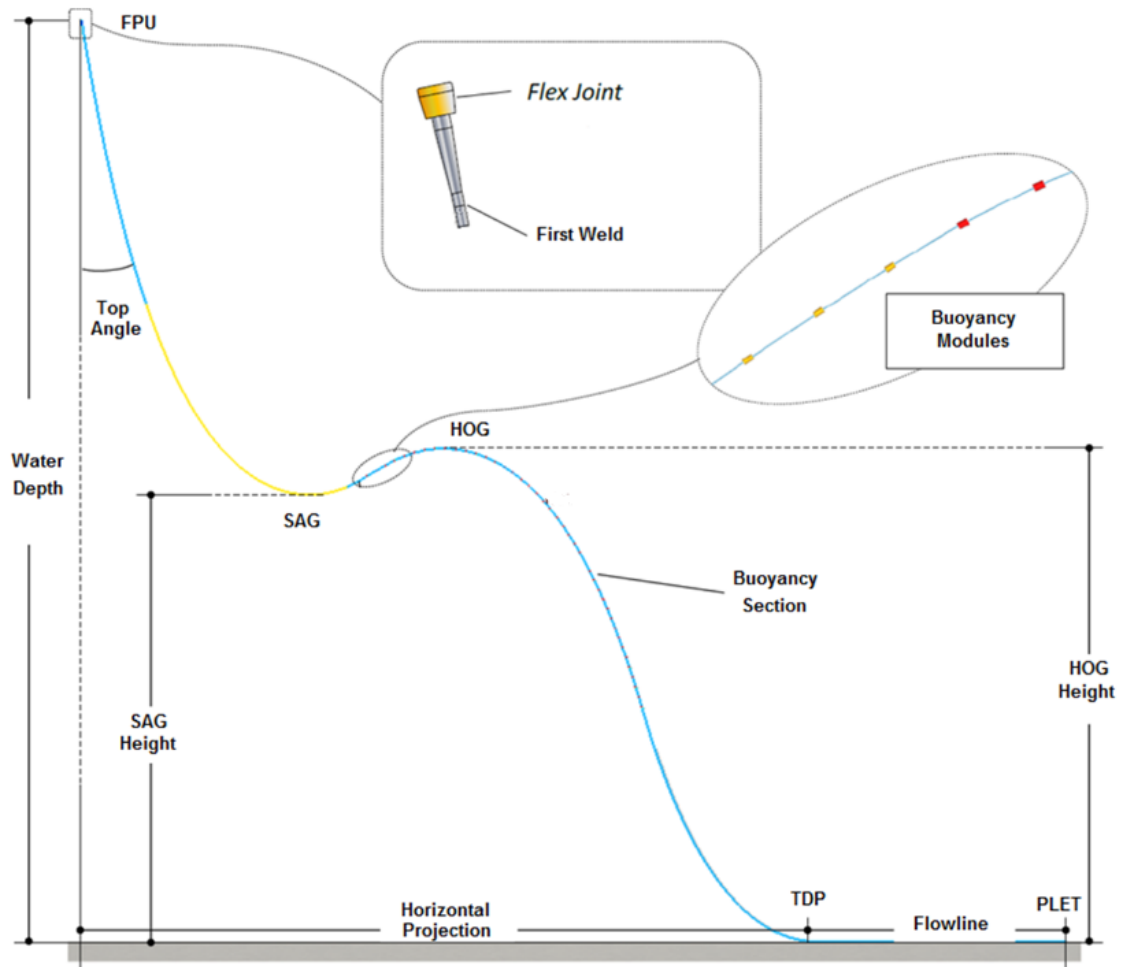

Figure 1 – SLWR Configuration



## 2. DESIGN ANALYSIS REQUIREMENTS

A document designated “**Riser Design Basis Report**” will be generated at the beginning of this Detailed Structural Design, as described in section 10.1.1, incorporating all final supplier data involved in riser configurations.

The document “**Riser Design Premises and Methodology Report**” shall detail and describe the methodologies and/or design requirements, applied codes, design criteria and any additional engineering assumption that are not clearly defined and established in this technical specification, as described in section 10.1.2. The computer programs or finite element package to be used shall be named and described. Any methodology criteria or design parameter that is not mentioned in this Technical Specification, but is considered necessary to the design, shall be submitted to PETROBRAS for approval and incorporated in the final version of the “**Riser Design Basis Report**” or in the “**Riser Design Premises and Methodology Report**”, depending on the type of information (see sections 10.1.1 and 10.1.2).

The analyses methodology described in next sections **may solely be modified with PETROBRAS consent**. CONTRACTOR may include additional items considered essential to improve the reliability of the design, and this shall be submitted to PETROBRAS for approval.

The main verification tasks covered by this document are:

- Establishment of a representative structural global analysis model;
- Extreme Combined Load Effect Analysis;
- Wave and Motion Fatigue Analysis;
- Current VIV Fatigue Analysis;
- Heave-Induced VIV Fatigue Analysis;
- Slugging Effect Analysis.

The following tasks are covered by other technical specifications:

- Wall Thickness Sizing Verification (see references [3], [9], [10], [11] and [12]);
- **Riser** Interference Analysis (see reference [13]);
- **Riser** Installation Analysis (see reference [14]);
- **Riser Top Connector Structural Analysis** (see references [19], [20], [21] and [22]);
- Riser-Soil Interaction Analysis (see reference [15]);
- Pre-Lay, Wet Storage and Recovery Analysis (see reference [32]).



<b>TECHNICAL SPECIFICATION</b>	Nº: <b>I-ET-0000.00-0000-274-P9U-001</b>	REV. <b>H</b>
GENERAL		SHEET: 10 de 72
TITLE:	<b>SLWR DETAILED STRUCTURAL DESIGN REQUIREMENTS</b>	EDR
		-

The basic Codes are referred in section 11. Other codes may be referenced or used in any specific aspect if subjected to PETROBRAS for approval.

The following sections 5, 6 and 7 will provide two approaches for the riser design: one with the **base case** main parameters and other with **sensitivity studies** for possible variations of these parameters. Note that the CONTRACTOR **shall guarantee the accomplishment of the design criteria for both approaches.**

### 3. DESIGN DATA DEFINITION

Table 1 considers the totality of data that will be the input for the detailed verification of the risers.

Table 1  
Analysis Data

SEQ.	DATA	DATA SOURCE
1	<b>FPU DATA</b>	
1.1	Calibrated RAOs (for all operational drafts)	See reference [2].
1.2	Operating time frequency of RAO drafts for Fatigue Analysis	See reference [2].
1.3	Extreme Circular Offsets in terms of water depth percentage (%) for Extreme Analysis	See reference [2].
1.4	Offsets for Wave Fatigue Loading Cases.	See reference [2].
1.5	Calibrated FPU 2 <sup>o</sup> order motions for representative drafts, in terms of harmonic motion and/or time traces, for Extreme and Fatigue analyses, when applicable	See reference [2].
1.6	Alternatively, time traces of Full dynamic response (1 <sup>st</sup> and 2 <sup>nd</sup> order random motions from coupled model)	See reference [2].
1.7	The angle magnitudes and directions to be considered in the platform hull damaged – accidental condition for Extreme Analysis	See reference [2].
1.8	Vortex Induced Motions (VIM): time traces or pairs of amplitude-period corresponding to loading cases, when applicable	To be provided by PETROBRAS in reference [2]. Not applicable for FPSOs.
1.9	FPU Heading for SMS (spread mooring) and FPU Heading per loading case for SPM (turret mooring) for Extreme and Fatigue analyses	See reference [2].
1.10	Drawings showing the riser connection points, the riser function sequence and riser azimuths	See reference [2].
1.11	Data of the fairleads locations and mooring lines configuration to be used in the Interference verification between riser and mooring	See reference [2].
1.12	FPU drafts	See reference [2]. All operational drafts provided will be used.
1.13	The relative angle between turret type FPSO and waves to be considered in the Extreme Analysis	To be provided by PETROBRAS in reference [2], if applicable. Not applicable for spread moored SMS FPU.

1.14	Directional offsets to be adopted in the Interference Analysis	See reference [2].
2	<b>METOCEAN DATA</b>	
2.1	Wave fatigue loading cases with correlated bi-modal waves, current profiles and winds	See reference [17].
2.2	Fatigue current profiles (*1)	See reference [16].
2.3	Extreme waves	See reference [16].
2.4	Extreme currents (*1)	See references [16].
2.5	Duration and evolution of extreme current profiles for VIV and Interference Analyses (*1)	See reference [17].
3	<b>GEOTECHNICAL DATA</b>	
3.1	Soil Vertical and Lateral Stiffness for different pipe embedments, depending on the analysis type (see section 4.7)	Based on reference [15].
3.2	Equivalent lateral and axial friction coefficients for different pipe embedments, depending on the analysis type (see section 4.7)	Based on reference [15].
3.3	Seabed slope in the riser plane, between TDZ and TRF (see section 4.7)	Based on reference [15].
3.4	Soil bathymetry (see section 4.7)	Based on reference [2]
4	<b>TOP CONNECTION</b>	
4.1	Riser top connector: Flexible Joint (FXJ), Stress Joint (SJ), Titanium Pull-in Tube (TIPT)	See reference [2].
4.2	Flexible Joint (FXJ) data	To be provided by CONTRACTOR, according to the supplier information, when FXJ is the connection type. See references [19][22]
4.3	Stress Joint (SJ) data	To be provided by CONTRACTOR, according to the supplier information, when SJ is the connection type. See references [20][22]
4.4	Titanium Pull-in Tube (TIPT) data	To be provided by CONTRACTOR, according to the supplier information, when TIPT is the connection type. See reference [21]
4.5	Length and geometry of the Top Connection joint Extension	To be defined by CONTRACTOR.

4.6	Receptacle angle	See reference [2].
4.7	Support/ receptacle limit loads	See reference [2].
4.8	Support type and dimensions	See reference [2].
5	<b>RISER DATA</b>	
5.1	Internal diameter	See reference [2].
5.2	Wall thickness(ess) (unique along the riser or values along the riser with the curvilinear position of the transitions, if any)	To be defined by CONTRACTOR.
5.3	Steel grade	See reference [2].
5.4	Top angle	To be defined by CONTRACTOR, in accordance with Receptacle angle (section 4.10) and submitted for PETROBRAS approval.
5.5	Riser PLET location	See reference [2]. Defined by PETROBRAS at the subsea layout.
5.6	Corrosion allowance	See reference [2].
5.7	Minimum length of clad pipe	See reference [2].
5.8	Thickness for thermal insulation coating	To be calculated by CONTRACTOR based on the requirements defined by PETROBRAS. See reference [2].
5.9	Design Life	See reference [2].
5.10	S-N curves to be used in the damage evaluation, on the internal and external fibers of the riser cross section, for the clad pipes, lined pipes and C-Mn pipes, considering sensitive and non fatigue sensitive sections	See reference [2]. Any change coming from the welding qualification program shall be incorporated.
5.11	Penalty factor to be used for the S-N curve for C-Mn pipes, as a function of the corrosion-fatigue effect of aggressive internal contents	See reference [2].
5.12	Internal misalignment (hi-lo) value to be used in the SCF calculation	See reference [26].
5.13	Initial ovalization (fabrication and reeling, if applicable)	To be defined by CONTRACTOR.
5.14	Fabrication tolerances with relation to wall thickness	Clad pipes, lined pipes and C-Mn pipes: to be defined by CONTRACTOR, based

		on supplier information and PETROBRAS requirements [9][10][11][12].
5.15	Weights (dry and wet) to be considered to represent the J-LAY collars or sleeves, when applicable.	Dimensions shall be proposed by CONTRACTOR.
5.16	Maximum structural damping	0.3%
5.17	Safety Factor for Wave&Motion and Slug fatigue analyses (for safety class high)	DFF1 = 10
5.18	Safety Factor for VIV and Heave induced fatigue analyses (for safety class high)	DFF2 = 20 for linear damage summation. DFF1 = 10 for quadratic damage summation.
5.19	Minimum <b>total fatigue life</b> (factored by DFFs) to be achieved by non fatigue sensitive riser sections	40*Design Life (see item 5.9 above).
<b>6</b>	<b>OPERATIONAL CONDITIONS</b>	
6.1	Riser Function	See reference [2].
6.2	Profiles of pressure, temperature and internal fluid density data for design, operational, incidental and transient conditions	See reference [30].
6.3	Pressure, density (gas and liquid), velocity (gas and liquid) and liquid holdup profiles along the entire riser length for each time-step, during at least one entire slug cycle, for Severe Slugging Analysis	To be provided by PETROBRAS, if applicable, based on riser geometry defined by CONTRACTOR.
6.4	Hydrodynamic slug characterization (frequency, gas bubble and liquid piston lengths, gas fraction, liquid holdup, velocities and densities) in some specific points along the riser length for Hydrodynamic Slugging Analysis	To be provided by PETROBRAS in reference [2], if applicable.
<b>7</b>	<b>POSITIONING ERRORS</b>	
7.1	Subsea equipment (anchor system or fixed point) positioning error	See reference [2].
<b>8</b>	<b>VIV SUPPRESSOR</b>	
8.1	Suppressor type to be considered	See reference [2] and [33].
<b>9</b>	<b>BUOYANCY MODULES</b>	
9.1	Buoyancy modules characteristics (for lazy-wave configuration application).	To be defined by CONTRACTOR. See reference [34].
<b>10</b>	<b>DATA FOR INTERFERENCE ANALYSIS</b>	
10.1	Riser configuration data of neighbor flexibles and umbilicals.	Flexibles and Umbilicals: in case of CONTRACTOR scope, to be provided by



<b>TECHNICAL SPECIFICATION</b>	Nº: <b>I-ET-0000.00-0000-274-P9U-001</b>	REV. <b>H</b>
<b>GENERAL</b>		SHEET: 15 de 72
TITLE: <b>SLWR DETAILED STRUCTURAL DESIGN REQUIREMENTS</b>		EDR
		-

	Mooring lines data.	CONTRACTOR. Otherwise, to be provided by PETROBRAS.  Mooring lines: to be provided by PETROBRAS.
10.2	FPU geometrical characteristics near riser support	To be provided by PETROBRAS.
11	<b>PIPE SECTION PROPERTIES</b>	
11.1	Geometrical characteristics	See reference [2]

(\*1) For riser analyses, linear interpolation criteria for bottom current profile and indication of current velocity at level zero (surface) shall be in accordance with Appendix B.

<b>TECHNICAL SPECIFICATION</b>	Nº: <b>I-ET-0000.00-0000-274-P9U-001</b>	REV. <b>H</b>
<b>GENERAL</b>		SHEET: <b>16 de 72</b>
TITLE: <b>SLWR DETAILED STRUCTURAL DESIGN REQUIREMENTS</b>		<b>EDR</b>
		-

#### 4. STRUCTURAL GLOBAL MODEL DEFINITION

##### 4.1. FINITE ELEMENT MODEL

The finite element model to be used shall include the effect of steel riser coating (all layers), buoyancy modules, VIV suppressors and riser top connector (FXJ, SJ or TiPT) including the extension detailed geometry.

The finite element mesh shall be proven adequate through a sensitivity study that shall be presented and submitted to PETROBRAS for approval. The lengths of the finite element used shall be chosen according to the criticality of each section under analysis:

- Near the top region, the changing in wall thickness of the taper section shall be represented, requiring smaller elements. The FXJ extension dimensions and stiffness of the flexible element (per load combination) shall be defined by supplier.
- For the TDZ, the elements shall be shortened to adequately capture the riser-soil interaction.
- Also, in the buoyancy modules region (the convex and concave regions) smaller elements shall be used and each buoyancy module shall be modelled individually for all design criteria.

**It is highlighted that will be necessary to identify the monitoring system position on the FE mesh for each riser before starting all the analyses, in order to present at the end of design an envelope of riser efforts at this point, setting alarms on FPU for riser's operation, according to [35] or other document referring monitoring system in [1] and [2].**

##### 4.2. WALL THICKNESS

Minimum wall thickness for design checks shall be considered as described in DNV-ST-F201 [3].

The corrosion allowance, for C-Mn pipes, shall be considered as a corrosion occurring around the entire circumference of the specific section being verified.

Fabrication tolerances shall be considered as described in the design code and PETROBRAS requirements [9], [10], [11] and [12], according to the specifications of each pipe used.

The riser shall be simulated with the nominal characteristics and the forces calculated as if no corrosion or thickness reduction is present. The reduced section shall be considered for stress calculation.

For CRA layer, see section 4.3 bellow.

##### 4.3. CLAD AND LINED PIPES

For Extreme Load verification, clad and liner CRA layer shall be considered as contributing for riser weight and structural stiffness. However, the clad and liner CRA layer shall be neglected for the riser strength calculation. Thus, for the forces and bending moments evaluation, the clad and liner CRA layer



contribution shall be considered. On the other hand, the CRA layer thickness shall be subtracted from the pipe wall thickness and considered as a corrosion allowance for riser resistance evaluation.

When applying the above proposition, if in some situation the pipe does not meet the DNV code requirement [3], CONTRACTOR may propose an alternative procedure including clad/liner contribution to the total pipe resistance [8], [9] and [10]. This procedure shall be approved by PETROBRAS.

Lined pipes minimum curvature radius ( $RC_{min}$ ) obtained in the Extreme Loads or any pipeline maneuvering (including pre-lay and recovery if foreseen) global simulations shall be verified according to following equation:

$$RC_{min} = \frac{OD \cdot (OD - 2t_2)}{t_{liner}} \cdot SF$$

Where:

OD – pipe outer diameter

$t_2$  – backing steel wall thickness

$t_{liner}$  – liner thickness

SF – Safety Factor = 2

For Fatigue verification, the clad and liner can be considered as contributing for the weight, structural stiffness and strength, since the resultant stress on CRA layer do not surpass its SMYS (considering de-rating effect) and tests described in item 6.5 from [8] are performed. The verification shall be performed at **CRA internal** and **CRA external wall** (external being the interface between CRA and C-Mn).

#### 4.4. FLEXIBLE JOINT MODELING

The FXJ stiffness's in the flexional directions and in the torsional directions shall be considered according to document [19]. The stiffness curves provided by supplier shall be associated with events provided in reference [30]. A constant stiffness shall be applied for the static analyses. The stiffening factors shall be obtained based on the supplier stiffness curve and used in a conservative way. Consecutive stiffness refinement cycles proposed in Appendix A may be adopted to find an adequate and less conservative dynamic FXJ stiffness value per load case, depending on the parameter to be evaluated. This factor multiplies the basic reference stiffness value adopted in the static analyses, as a function of the FXJ alternating angle. If the resultant standard deviation of the alternating angle corresponds to a stiffening factor which is higher than the stiffening factor used in the simulation, then



the simulation shall be performed again with the higher stiffening factor, which will give higher reactive bending moments.

There are three different scenarios to define adequately the FXJ stiffness, where CONTRACTOR shall guarantee an adequate conservatism for each type of analysis, selecting the ideal curve and value following this guide:

- a) Extreme conditions to maximize top efforts: selecting the stiffer FXJ' curve, starting cycles with fixed maximum stiffness (corresponding to 0.01 of alternating angle) and performing optionally the refinement described in Appendix A per each load case;
- b) Extreme conditions to maximize cocking angle: selecting the less stiff FXJ' curve and mandatory performing the refinement described in Appendix A to select a lower stiffness value in the curve, differentiated per load case. At least two refinement cycles shall be adopted to determine an adequate FXJ angular variation and correspondent stiffness;
- c) Fatigue conditions: selecting operational scenario that provides the most stiff FXJ' curve, starting cycles with fixed maximum stiffness (corresponding to 0.01 of alternating angle) and performing optionally the refinement described in Appendix A, differentiated per load case. When performing FXJ stiffness refinement, the most critical loading cases shall be selected, at least the ones that totalize 99% of damage in each critical sections along the riser.

One possibility to avoid double the amount of extreme analysis is prioritize the *approach that maximizes the cocking angle* as base case, and then rerun the identified critical cases in the sensitivity with the *approach that maximizes top efforts and stresses*. In this case, for both approaches, a tolerance in stiffness shall be applied as per item 5.5.

The temperature and pressure effects on FXJ stiffness for each load category shall also be considered when CONTRACTOR is defining stiffness values to be employed in the analyses, as per [19].

The FXJ extension shall be modeled, including the representation of the tapered section in the finite element model.

The loading application point is the CoR defined by FXJ supplier design. A reference point "P" for interface load limit comparison shall be included at the base of the selected support, as per section 7.

In the case of HOA FXJ [22], the Hang-off Adaptor shall be modeled as rigid link, connected to the base of the selected Support–Tube and to the CoR. The riser shall be connected to the CoR below the rigid link/ HOA.

#### 4.5. STRESS-JOINT MODELING

The SJ shall be modeled with tapered and straight sections that should result from sizing performed by SJ supplier, using riser top loads. Material properties (mechanical, fatigue curves, de-rating of stresses and E-modulus) shall observe the requirements of [20] or [21]. The SCF of geometric transitions (flange neck, tapered transitions) shall be calculated by FEM and included within the relevant models.



<b>TECHNICAL SPECIFICATION</b>	Nº: <b>I-ET-0000.00-0000-274-P9U-001</b>	REV. <b>H</b>
GENERAL		SHEET: 19 de 72
TITLE: <b>SLWR DETAILED STRUCTURAL DESIGN REQUIREMENTS</b>	EDR	
		-

The loading application point is the transition between the dynamic and static (restrained) sections, or the Top of Taper (ToT) defined by SJ supplier design. A reference point “P”, for interface load limits comparison, shall be included at the base of the selected support, as per section 7.

In the case of HOA TSJ [22], the Hang-off Adaptor shall be modeled as rigid link, connected to the base of the selected Support–Tube and to the ToT. The riser shall be connected to the ToT below the rigid link/ HOA.

#### 4.6. TITANIUM PULL IN TUBE MODELING

The TiPT shall be modeled in all its length, including the Steel Transition Spool, the representation of all the compact flanges along TiPT and SCF of the geometric transitions (flange neck, tapered transitions and inner diameter transition if required).

The LTSJ and UTSJ shall be modeled with tapered and straight sections that should result from sizing performed by SJ supplier, using riser top loads. Material properties (mechanical, fatigue curves, de-rating of stresses and E-modulus) shall observe the requirements of [21].

The hang-off connection at the top of the TiPT shall be represent as a crimp-fitting. The support-tube connection shall allow the relative movement of the TiPT through the Trumpet, in axial direction, and shall include the gap and the stiffness of the contact region between the UTSJ and the Trumpet. The position of the loading application point at the contact region shall be informed.

#### 4.7. SOIL MODEL

The riser-soil interaction data shall be described in Riser Design Basis Report and considered in analyses as per in the Riser Design Premises and Methodology Report, both to be submitted to PETROBRAS for approval. All information regarding the interaction with soil to be considered in risers design shall be obtained in accordance with document [15].

The seabed slope determined between TDP and TRF points or the bathymetry of each riser shall be considered for Extreme and Fatigue analyses. For Interference analysis, see document [13].

For extreme and fatigue conditions, CONTRACTOR shall determine the soil elastic stiffness and the equivalent friction coefficients to be used in the analyses, according to the soil-interaction analysis [15], for the embedment indicated in sections 5 and 6 respectively, and submit to PETROBRAS approval. For Interference analysis, see document [13].

The best estimate mean value (BE), in terms of stiffness and friction coefficients, shall be used as base case and the minimum/ maximum shall be used in the sensitivity analyses. The minimum value (LE) represents the lowest nominal value obtained from LE, BE and UE soil properties. Similarly, the maximum value (UE) represents the highest nominal value obtained from LE, BE and UE soil properties.

#### 4.8. MORISON COEFFICIENTS

The normal drag coefficients to be adopted for bare pipe and buoyancy sections shall be 1.2 for extreme simulations and 0.7 for fatigue simulations. The inertia coefficient for bare pipe and buoyancy sections shall be 2.0 in both simulations. **For Interference analysis, see document [13].**

In the buoyancy sections, longitudinal drag and inertia coefficients shall be adopted according to reference [7].

Riser lengths with VIV suppressors shall be properly considered and the adopted values for the drag and the inertia coefficients shall be justified.

**All these** values shall be justified in the **Riser Design Premises and Methodology Report** and presented in the **Riser Design Basis Report**.

#### 4.9. ANALYSIS SOFTWARE

Only a few commercially available software packages are accepted to be employed for the analyses. The adopted software shall consider the LRFD approach of DNV-ST-F201 [3].

Table 2 presents the names of the packages and the type of analyses for which they are applicable. In case of CONTRACTOR intend to use different softwares from the ones listed in Table 2, the requirement shall be submitted to PETROBRAS approval.

Table 2  
Analysis Software

TYPE OF ANALYSIS	SOFTWARE (*)
Fatigue / Extreme / Installation Fatigue/ Interference	FLEXCOM, from Wood Group, RIFLEX, from Sintef DEEPLINES, from Principia ORCAFLEX, from Orcina
VIV	SHEAR7 from MIT (Version 4.10 shall not be used)
Installation	FLEXCOM, from Wood Group, RIFLEX, from Sintef DEEPLINES, from Principia ORCAFLEX, from Orcina PIPELAY from Wood Group
General	ABAQUS, ANSYS

(\*) Care shall be taken with variable time steps in time domain dynamic analysis algorithms.

#### 4.10. GENERAL REQUIREMENTS

- Care shall be taken with the buoyancy modules distribution along the linepipe since they shall not be positioned close to the girth weld and triple point. Buoyance modules should be centered in the linepipe. The buoyance clamp shall have a minimum distance of 200mm from triple point or 100mm from the edge of field joint coating, whichever is greater. If necessary, better S-N fatigue curves may be considered for fatigue analysis of parent pipe material if sharp edges and surface flaws are improved by grinding, **as per Appendix A from reference [5]**. These additional

requirements shall be included in the visual examination procedure before coating. The buoyance distribution should not block the access for inspection of field joint coating area.

- Choose a specific FPU draft (for example, intermediate) and a mean internal fluid density to define the riser top angle and their correspondent riser horizontal projection (top connection to TRF). When changes are made on the FPU draft or on the internal fluid density, keep the same riser horizontal projection or a fixed TRF point.
- A minimum length of riser laid on seabed when defining the riser configurations is required in order to guarantee the TRF point as defined in item "DEFINITIONS". Identify in drawings the NO MOTION POINT (NMP).
- CONTRACTOR shall previously evaluate if will be necessary to carry out analyses related to on-bottom roughness, free-span and lateral stability for the riser sections between TDP and TRF. If confirmed, the same flowline analysis requirements shall be performed in accordance with [23] and [24].
- Proposed riser mean top angle may vary from the support top connection angle, conditioned to validation of top connection's supplier (see references [1], [19], [20] and [21]).
- The top interface loads shall be within the final FPU load limits (see reference [2]).
- For TiPT connector type, the top interface loads shall be calculated for lower and upper balcony and both compared with final FPU load limits (see reference [2]).
- The riser section with **VIV suppressor** should not touch the seabed for all internal fluid conditions and FPU drafts, including the load combinations related to buoyancy loss. **In case of Wet Storage condition, VIV suppressor shall be avoided in cycling region of both temporary TDPs. In case the adoption of VIV suppressor on TDZ (nominal in-place or temporary) is deemed necessary, it shall be specified and qualified for this purpose under cyclical loads.**
- The riser integrity shall be assured also during load transfer, pull-in, riser docking and abandonment.
- The proposed riser configuration (full of water by accidental flooded condition) shall guarantee the non-exceedance of FPU cable limit load for pull-in and pull-out operations, according to reference [2].
- If **specified for the riser design** more than one internal diameter **and/or** riser configuration for the same riser function, each one shall be treated separately in the selection of the critical riser and sensitivity studies. **As example:**
  - **PROD 8" and PROD 6.5"**
  - **same riser with different characteristics (as top angle and/or buoyance modules distribution and/or strake's coverage).**

## 5. EXTREME COMBINED LOAD EFFECT ANALYSIS

The objectives are:

- To demonstrate that the riser is designed to resist the potential modes of failure, when submitted to operational situations and severe environmental conditions, as defined in the DNV-ST-F201 [3] by using the LRFD method;
- To generate the pairs tension x angular deflections at the riser top (including at least Maximum Tension with associate angle and Maximum Angle with associate tension) for the specification of

<b>TECHNICAL SPECIFICATION</b>	Nº: <b>I-ET-0000.00-0000-274-P9U-001</b>	REV. <b>H</b>
<b>GENERAL</b>		SHEET: <b>22 de 72</b>
TITLE: <b>SLWR DETAILED STRUCTURAL DESIGN REQUIREMENTS</b>		<b>EDR</b>
		<b>-</b>

the riser top connector. The maximum top riser connector rotation shall include the vessel compartment flooded condition;

- To demonstrate that the limits of the compressive axial loads to happen at the riser top are not violated, in order to preserve the interface device integrity, according to supplier's information and FPU requirements;
- To generate maximum riser top loads to be verified with relation to the attendance of load limits from riser balcony and supports structures;
- To verify if the minimum curvature radius along the line for all loading cases is higher than the minimum value calculated according to section 4.3, for riser with liner CRA layer to avoid wrinkling;
- To generate riser footprint that corresponds to the envelope of TDP positions during Design life;
- To generate loads for the design of the riser anchoring system.

The general methodology requirements are listed below:

- a) The dynamic analysis shall consider the effects of wave, currents and wind acting on the platform, and the effects of currents and waves acting directly along the steel riser;
- b) FPU motions shall be derived from RAO data and second order motions (when applicable), or alternatively time traces of the complete motions (first + second order). All these parcels shall be considered in the wave screening described in 5.3;
- c) Note that the roll RAO curves can be provided considering different levels of viscous damping for Roll DOF, that shall be adopted appropriately for extreme contour waves and for operational fatigue waves. Details related to each damping level will be provided accordingly;
- d) Static FPU offsets, considered in the riser analyses, will correspond to the values provided by PETROBRAS, according to item 1.3 of Table 1. The errors shall be added to the specified offset always in the most conservative way, according to item 7.1 of Table 1;
- e) The relative phase angle between motions and waves direct action over the riser shall be considered in the analyses. It is possible that PETROBRAS decides to provide time traces from a coupled model;
- f) All operational drafts shall be considered according to section 1.12 of Table 1;
- g) All internal fluid characteristics provided in section 6.2 of Table 1 shall be considered in the analyses. Alternatively, CONTRACTOR can propose a fluid screening to select among some group of fluids which ones will provide the most critical results to be considered as a base case, covering operational and temporary fluid conditions, and submitted to PETROBRAS for approval. At least one representative minimum, medium and maximum fluid densities and empty condition shall be selected as base case. For risers operating with more than one function, the fluid content for each function associated with respective operating condition shall be included. All fluids not selected as base case shall be analyzed in sensitivity study;

- h) Negative effective tension values (compression) along the riser can be accepted if DNV-ST-F201 [3] recommendations are accomplished. For this purpose, the FE mesh shall be refined enough to demonstrate the convergency of effective tension, bending radius and bending moment;
- i) Negative effective tension values (compression) at the riser top shall be limited to the value prescribed by the supplier of the riser top connector and FPU interface requirements (see reference [2]);
- j) The maximum riser top loads shall be lower than the final FPU limits to be informed accordingly by PETROBRAS;
- k) For lined and clad pipes verification, CONTRACTOR shall refer to section 4.3;
- l) Yield strength de-rating for backing steel shall be considered according to reference [4]. If the strength contribution of CRA is considered in the analysis, tensile properties for CRA layer affected by temperature shall be defined according to reference [8];
- m) The soil stiffness and friction values adopted shall correspond to the medium values associated to 25% of riser embedment;
- n) For each dynamic loading case simulated, a FXJ alternating angle shall be identified and the stiffening factor shall be adopted in the analysis, as defined in item 4.4.
- o) CONTRACTOR shall adopt for the buoyance modules the EOL condition as a base case, due to soak/compressive/creep effects informed by supplier.

### 5.1. LOAD COMBINATIONS FOR ULS AND ALS

The load combinations to be simulated shall follow DNV-ST-F201 [3]. A minimum set is described in Table 3. PETROBRAS will provide corresponding FPU offsets as indicated in section 1.3 of Table 1.

Table 3  
Load Combinations for the Steel Riser Design

LOAD COMBINATION	MODE OF OPERATION	WIND RETURN PERIOD (YEARS)	WAVE RETURN PERIOD (YEARS)	CURRENT RETURN PERIOD (YEARS)	INTERNAL FLUID PROFILES (*1)	NOTES
ULS1	TEMPORARY	1	1	1	N/A	<ul style="list-style-type: none"> <li>Hydrotest pressure. Full of water. Test water density and temperature as per CONTRACTOR PreCom Procedure. Actual values shall be recorded, per ref. [29].</li> <li>Only for Flexible Joint design, sea state associated with ULS1 may be reduced, according to [19].</li> </ul>
ULS2	OPERATING	100	100	10	DESIGN, OPERATING	<ul style="list-style-type: none"> <li>Intact hull &amp; mooring</li> </ul>
ULS3	OPERATING	10	10	100	DESIGN, OPERATING	<ul style="list-style-type: none"> <li>Intact hull &amp; mooring</li> <li>Only for Flexible Joint design, the current return period associated with ULS3 may be reduced, according to [19].</li> </ul>
ULS4	OPERATING	1	1	1	INCIDENTAL	<ul style="list-style-type: none"> <li>Intact hull &amp; mooring</li> </ul>
ULS5	OPERATING	1	1	1	DESIGN	<ul style="list-style-type: none"> <li>Intact hull &amp; mooring</li> <li>Only to SPM FPU for beam seas conditions</li> </ul>
ALS1	ACCIDENTAL	100	100	10	DESIGN, OPERATING	<ul style="list-style-type: none"> <li>One mooring line broken</li> </ul>
ALS2	ACCIDENTAL	10	10	100	DESIGN, OPERATING	<ul style="list-style-type: none"> <li>One mooring line broken</li> </ul>



ALS3A (-) ALS3B (+) ALS3C (-) ALS3D (+)	ACCIDENTAL	1	1	1	DESIGN, OPERATING	<ul style="list-style-type: none"> <li>Platform with compartment flooded. Value and inclination direction given by PETROBRAS, according to section 1.7 in Table 1.</li> <li>Combinations ALS3C and ALS3D are without offset.</li> </ul>
ALS4	ACCIDENTAL	100	100	10	DESIGN, OPERATING	<ul style="list-style-type: none"> <li>Loss of buoyancy modules (see Table 5)</li> </ul>
ALS5	ACCIDENTAL	10	10	100	DESIGN, OPERATING	<ul style="list-style-type: none"> <li>Loss of buoyancy modules (see Table 5)</li> </ul>

(\*1) Internal fluid profile defined as per item 6.2 from Table 1.

Design conditions shall be simulated considering the design pressure profile, always combined with the maximum design temperature along the riser length, combining at least with minimum, average and maximum densities.

Operating conditions shall be simulated considering its associated profiles (pressure, temperature and density).

A scenario that maximizes the external overpressure on TDP shall be simulated, considering minimum pressure combined with minimum density and maximum design temperature.

CONTRACTOR may propose a fluid screening for PETROBRAS approval. See item (g) above.

Incidental condition shall be simulated considering the incidental pressure profile, always combined with the maximum design temperature along the riser length, combining at least with minimum, average and maximum densities.

Table 4 presents a model to be followed and presented in the document of **Riser Design Premises and Methodology Report**, with respective values and fluid codes from [2] [30].

Table 4  
Load Combinations from Table 3

Scenarios	Top Pressure	Density Profile	Fluid Code	ULS1	ULS2	ULS3	ULS4	ULS5	ALS1	ALS2	ALS3A/ ALS3B (*4)	ALS4	ALS5
INCIDENTAL Incidental Pressure	TBD	Minimum Fluid Density	TBD				X						
		Average Fluid Density	TBD				X						
		Maximum Fluid Density	TBD				X						
DESIGN Design Pressure	TBD	Minimum Fluid Density (*1)	TBD		X	X		X	X	X	X	X	X
		Average Fluid Density (*1)	TBD		X	X		X	X	X	X	X	X
		Maximum Fluid Density (*1)	TBD		X	X		X	X	X	X	X	X
OPERATING A Maximum Pressure	TBD	Associated density and temperature profile	TBD		X	X		X	X	X	X	X	
OPERATING B Maximum Temperature	TBD	Associated density and pressure profile	TBD		X	X		X	X	X	X	X	
OPERATING C Minimum Operational Pressure	TBD	Associated density and temperature profile (*2)	TBD		X	X		X	X	X	X	X	
Hydrotest Pressure	TBD	TBD	TBD	X									
Hybernation (if applicable)	0	TBD	TBD		X	X		X	X	X	X	X	
Empty (*3)	0	NA	E1		X	X		X	X	X	X	X	

(\*1) Density profiles shall be extracted from [2] [30] and shall include the all fluid profiles.



(\*2) In order to verify external overpressure effects at TDP. To select a scenario which combines low pressure level with high temperature.  
 (\*3) Without internal pressure.  
 (\*4) ALS3C/ ALS3D just for the most critical load case from ALS3A/ ALS3B, as per Table 6.

The complete set of FPU motions corresponding to operational FPU drafts shall be considered in the design. In the following sections, there is a description how CONTRACTOR can proceed to combine loads in order to take all of them into account, without having to process a very large number of loading cases.

Follow Table 5 to consider the quantity of loss buoyancy modules, typically more critical condition losing at the top of the HOG and at the ending of floated segment (from HOG to SAG). CONTRACTOR shall propose a combination of loss buoyancy modules for PETROBRAS approval.

Table 5  
Number of lost buoyancy modules

QTY OF BUOYANCY MODULES	QTY OF LOST BUOYANCY MODULES
Less than 15	1
15 to 39	2
40 to 60	3
More than 60	4 or 4%, whichever is higher

## 5.2. LOADING CASES

Wave and current data are given in 22,5° intervals between 0° and 360° [2], giving a total of 16 (sixteen) directions. They shall be defined as N, NNE, NE, ENE, E, ESE, SE, SSE, S, SSW, SW, WSW, W, WNW, NW and NNW, according to Figure 2. So, for each load combination listed on Table 3, 16 (sixteen) environmental load directions shall be considered, regardless of the global reference system (XG, YG), in order to cover all possible critical situations that can be faced by the riser. Moreover, for each environmental load direction, a complete set of pairs Hs x Tp shall be considered, as mentioned in section 5.3.

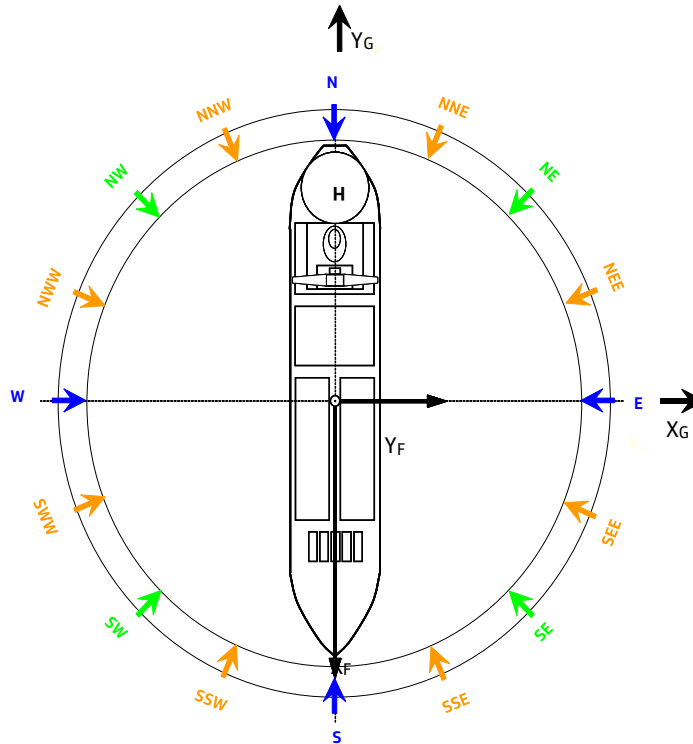

Figure 2 – Global Environmental Load Directions

### 5.2.1. For SMS FPU

The analyses shall be performed for both collinear and non collinear approaches, combining waves, currents and offsets:

For collinear environmental conditions (see Table 7), combine currents (surface and mid-depth) with waves. The FPU offsets shall follow the wave directions.

For non collinear environmental conditions (see Table 7), combine currents (surface and mid-depth) with waves 45 deg apart. The FPU offsets shall follow the wave directions.

- for surface current profiles aligned cases, combine two more current profiles (choose neighbor current profiles directions with  $\pm 22.5^\circ$  from original aligned direction). Moreover, combine with original static offset and zero offset.
- for mid-depth current profiles aligned cases, combine mid-depth current profiles in all direction from Metocean. Moreover, combine with original static offset and zero offset.

For waves in scenarios with spread mooring system, CONTRACTOR shall use the extreme single peak wave from metocean [16].

### 5.2.2. For SPM FPU

The analyses shall be performed for three following approaches, combining waves, currents and offsets (see Figure 3 and Table 8):

- Head seas conditions shall be considered with collinear wave and current. The FPU offset and heading shall be considered aligned with wave comes from bow to stern. In total, 16 FPU heading directions shall be assessed, combined with all load combinations from Table 3, except ULS5. For head seas conditions CONTRACTOR shall use the extreme single peak wave from metocean [16];
- Quartering seas conditions shall be considered with waves and currents approaching the FPU  $\pm 22.5$  deg from the bow (considering the FPU longitudinal axis), always 45 deg apart from each other (See Figure 3). The FPU offset and heading shall be considered in the middle of wave and current. In total, 16 FPU heading directions shall be assessed, combined with all load combinations from Table 3, except ULS5. For quartering seas conditions CONTRACTOR shall use the extreme single peak wave from metocean [16];
- Beam seas conditions shall be evaluated, in order to represent bimodal wave conditions. The FPU heading and offset shall be considered in the same direction of surface current (see Figure 3). In total, 7 FPU heading directions (the quantity depending on the Metocean data [16]) shall be assessed (according to [16]), combined with load combination ULS5 from Table 3. Just for beam seas conditions CONTRACTOR shall use the extreme double peak wave from metocean [16]. In this condition, IWP approach (see section 5.4.2) shall be directly adopted for the selected waves in wave screening. If PETROBRAS has additional information for specific project, it will be informed to CONTRACTOR.

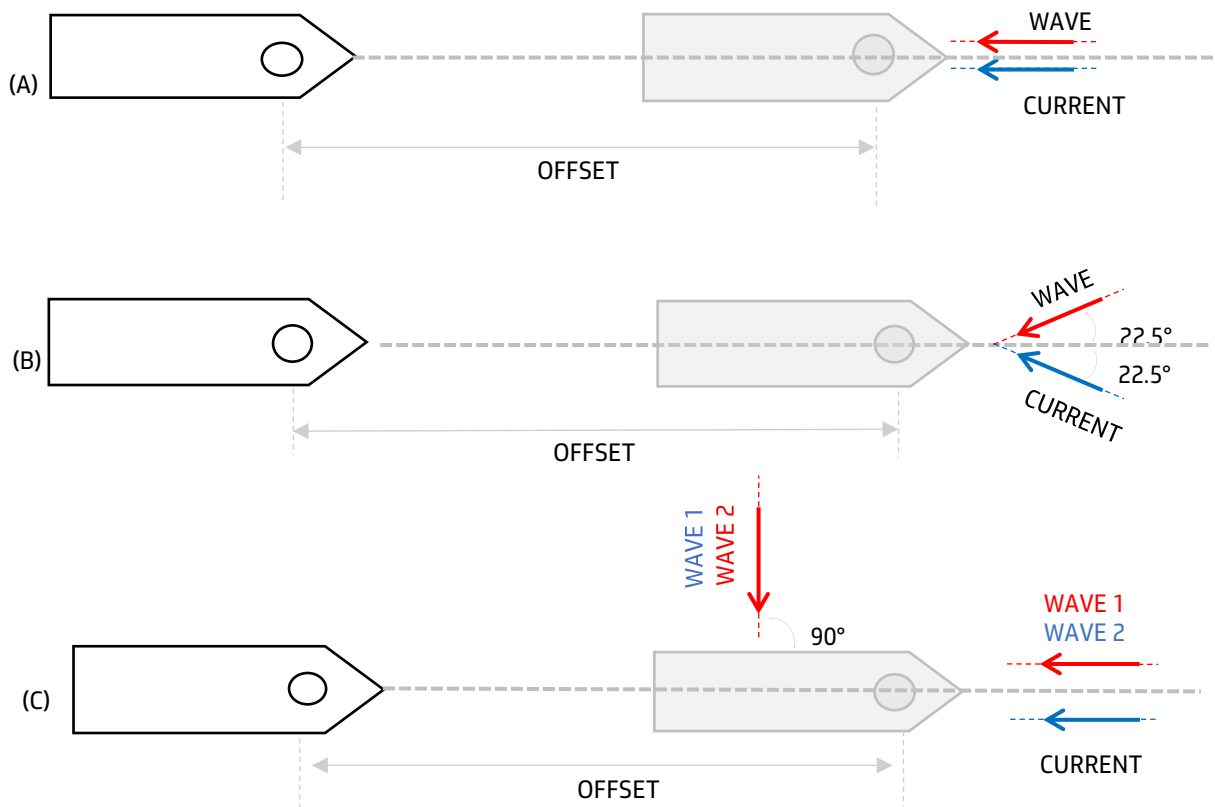

Figure 3 – Environmental conditions for SPM FPUs:  
 (A) Head seas (b) Quartering seas (c) Beam seas

### 5.3. WAVE SCREENING

In the Metocean, for each recurrence period (1-year, 10-year and 100-year) and direction, there is a set of Hs-Tp pairs (contour curves). When selecting waves to perform the riser dynamic analyses, one option is to process the entire number of existent pairs, but this procedure will result in a high number of dynamic analyses.

An alternative approach, considered acceptable by PETROBRAS, is to perform the wave screening to select a subset of load cases, with the previous calculation of the FPU short-term maximum responses at each riser connection points, based on each FPU draft RAOs, with the entire set of pairs Hs x Tp for the 16 directions and for each recurrence period (depending on the loading combination from Table 3). For storage units, all provided drafts shall be analyzed in this study, and the results for each five parameters described below shall be associate with the draft that provides the most critical value.

If applicable, the contribution of second order motions in terms of maximum amplitudes, velocities and accelerations shall be considered in the wave's selection of wave screening, not only by the rotational motion itself but also including its induced vertical motion. In this case, two steps are required to select the loading cases:

- First, critical loading cases by 1<sup>st</sup> order motions (by RAOs);
- Additionally, including critical loading cases by 1<sup>st</sup> + 2<sup>nd</sup> order together.

Based on the results of FPU motion responses, CONTRACTOR shall select, for each connection point and wave direction, at least five loading cases (waves/drafts) according to the following parameters described in Figure 4, which presents a flowchart of the alternative motion analysis procedure as the **first step** to select most critical waves for extreme analysis (see Figure 5 describing the **following steps**).

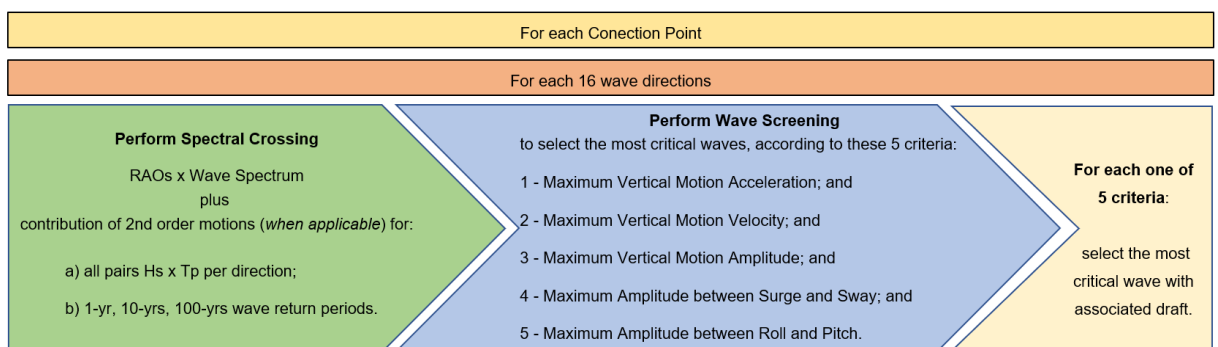

Figure 4 – Wave screening

For the riser analysis, all selected loading cases of all 16 environmental load directions from wave screening (with corresponding FPU draft) shall be simulated, for each corresponding load combination from Table 3, and for each combination internal fluid density/pressure from reference [2] or fluids

selected in fluid screening (see item (g) from section 5), with two types of current profiles (surface and mid-depth). From Table 3, some load combinations admit a reduced number of loading cases, based on the most critical riser response from other load combinations, as described in Table 6.

Table 6  
Reduced Loading Cases for some Load Combinations

REDUCED LOADING CASES (*1)	BASED ON CRITICAL CASES FROM	CRITERIA
ALS1	ULS2	Highest DNV UF at TDP Highest DNV UF at SAG & HOG Highest DNV UF at Top Maximum and Minimum FX, FY, FZ, MX, MY, MZ at the riser top (see Figure 7)
ALS2	ULS3	
ALS4	ULS2	Highest DNV UF at TDP Highest DNV UF at SAG & HOG Highest DNV UF at Top Maximum and Minimum FX, FY, FZ, MX, MY, MZ at the riser top (see Figure 7)
ALS5	ULS3	
ALS3C	ALS3A	<i>maximum top riser rotation angle</i>
ALS3D	ALS3B	

(\*1) The reduced loading cases may be applied just if the offset difference between intact and damaged condition is up to 0.5% of SWL.

Additionally, a non-colinear approach (waves, currents and FPU offsets) shall be verified for SMS FPU, for all load combinations from Table 3:

- For the worst DNV UF cases (3 different regions: TDP, SAG&HOG and Top) with surface current profiles aligned cases.
- For the worst DNV UF cases (3 different regions: TDP, SAG&HOG and Top) with mid-depth current profiles from aligned cases.
- **For the maximum Top riser rotation angle.**

The procedure used by CONTRACTOR in the selection of critical waves shall be presented in the **Riser Design Premises and Methodology Report** and submitted to PETROBRAS for approval.

Table 7 and Table 8 present an estimative of maximum number of loading cases to be analyzed for SMS FPU and SPM FPU respectively, if none of 5 pairs Hs-Tp per draft is repeated, i.e., the number of loading cases can be lower, depending on the results of wave screening.

Table 7  
Number of Loading Cases for SMS FPU simulation per riser position

	LOAD COMBINATIONS	WAVES/ DRAFT (*1)	WAVE DIRECTIONS	CURRENT PROFILES	OFFSET (*3)	2ND ORDER PHASE ADJUSTMENT (*2)	TOTAL LOADING CASES
Colinear Conditions	ULS1	5	16	2	1	2	320
	ULS2	5	16	2	1	2	320
	ULS3	5	16	2	1	2	320
	ULS4	5	16	2	1	2	320
	ALS1 (*5)	5	16	2	1	2	320
	ALS2 (*5)	5	16	2	1	2	320
	ALS3 A and B (*4)	5 + 5	16	2	1	2	320 + 320
	ALS3 C and D (*4)	1 + 1	1	1	1	1	1 + 1

	ALS4 (*5)	5	16	2	1	2	320
	ALS5 (*5)	5	16	2	1	2	320
Non-colinear Conditions	Worst DNV UF at TDP (surface currents)	1	1	2	2	1	4
	Worst DNV UF at SAG&HOG (surface currents)	1	1	2	2	1	4
	Worst DNV UF at TOP (surface currents)	1	1	2	2	1	4
	Worst DNV UF at TDP (mid-depth currents)	1	1	8	2	1	16
	Worst DNV UF at SAG&HOG (mid-depth currents)	1	1	8	2	1	16
	Worst DNV UF at TOP (mid-depth currents)	1	1	8	2	1	16
Maximum total number of loading cases per fluid/pressure and per connection point							3262

(\*1) Waves means 5 pairs Hs-Tp selected by criteria presented in Figure 4. The most critical draft for each 5 pairs Hs-Tp of wave screening may be adopted. Each 5 pairs Hs-Tp shall be selected for each 16 wave directions, combined with 2 types of current profiles and with 2 types of phase adjustment (described below) and finally performed for each load combination described in Table 3.

(\*2) When 2<sup>nd</sup> order roll motion is applicable, the phase adjustment will be applied for the vertical motion and roll motion. If CONTRACTOR demonstrates through riser analysis that one of the options for phase adjustment is predominantly most critical than the other, just this most critical can be adopted (per riser function). In this case, it shall be submitted to PETROBRAS for approval.

(\*3) For colinear conditions, when using mid-depth current profiles, align the offsets with the wave direction when the vessel is an FPSO.

(\*4) For load combinations ALS3A and ALS3B, the loading case that present the maximum top riser rotation angle shall be reassessed considering zero offset (ALS3C and ALS3D), only to verify if this new condition can bring higher top riser rotation angle. If the higher angle is confirmed to occur in this condition, it shall be additionally included in the top connector loading case matrix with its respective effective tension.

(\*5) May have a reduced quantity of loading cases based on Table 6.

**Table 8**  
Number of Loading Cases for SPM FPU simulation per riser position

	LOAD COMBINATIONS	WAVES/DRAFT (*1)	WAVE DIRECTIONS			CURRENT PROFILES	OFFSET	2ND ORDER PHASE ADJUSTMENT (*2)	TOTAL LOADING CASES
			HEAD SEAS	QUARTERING SEAS	BEAM SEAS				
Colinear/ Non-colinear Conditions	ULS1	5	16	16*2	-	2	1	2	960
	ULS2	5	16	16*2	-	2	1	2	960
	ULS3	5	16	16*2	-	2	1	2	960
	ULS4	5	16	16*2	-	2	1	2	960
	ULS5 (*4)	5	-	-	7*2	1	1	2	140
	ALS1	5	16	16*2	-	2	1	2	960
	ALS2	5	16	16*2	-	2	1	2	960
	ALS3 A and B (*3)	5 + 5	16	16*2	-	2	1	2	960 + 960
	ALS3 C and D (*3)	1 + 1	1	1	1	1	1	1 + 1	1 + 1
	ALS4	5	16	16*2	-	2	1	2	960
ALS5	5	16	16*2	-	2	1	2	960	
Maximum total number of loading cases per fluid/pressure and per connection point									9742

(\*1) Waves means 5 pairs Hs-Tp selected by criteria presented in Figure 4. The most critical draft for each 5 pairs Hs-Tp of wave screening may be adopted. Each 5 pairs Hs-Tp shall be selected for each 16 wave directions, combined with 2 types of current profiles and with 2 types of phase adjustment (described below) and finally performed for each load combination described in Table 3.

(\*2) For example: when 2<sup>nd</sup> order roll motion is applicable, the phase adjustment will be applied for the vertical motion and roll motion.

<b>TECHNICAL SPECIFICATION</b>	Nº: <b>I-ET-0000.00-0000-274-P9U-001</b>	REV. <b>H</b>
<b>GENERAL</b>		SHEET: <b>31 de 72</b>
TITLE: <b>SLWR DETAILED STRUCTURAL DESIGN REQUIREMENTS</b>		<b>EDR</b>
		<b>-</b>

(\*3) For load combinations ALS3A and ALS3B, the loading case that present the maximum top riser rotation angle shall be reassessed considering zero offset (ALS3C and ALS3D), only to verify if this new condition can bring higher top riser rotation angle. If the higher angle is confirmed to occur in this condition, it shall be additionally included in the top connector loading case matrix with its respective effective tension.

(\*4) For ULS5, just surface current referenced profiles will be analyzed. Two combinations of wave peak 1 and wave peak 2 from extreme double peak waves will be applied for head and beam directions.

#### 5.4. SIMULATION OF IMPOSED MOTIONS AND WAVES

The motion and wave modeling procedures shall encompass hybrid approach represented by equivalent harmonic excitation and complemented by random simulation, both in time domain based on spectral wave description, in order to capture the nonlinearities that are present in the riser dynamic response under extreme loads.

For the deterministic approach is defined the Equivalent Harmonic Motion Procedure (EHMP) for the first order FPU motions, described in the section 5.4.1. In loading cases with second order motions for DOF out of horizontal plane (Heave, Roll and Pitch DOF's), PETROBRAS will provide harmonic signals for each DOF, in terms of amplitude and period, to be composed with the first order motions. CONTRACTOR shall adjust the phases between first and second order motions, both for Vertical Motion and Rotational Motions involved. Critical loading cases identified with this hybrid approach analyses shall be checked using a random approach.

For the random approach is defined the Irregular Wave Procedure (IWP) analysis for the first and second order FPU motions, **described in section 5.4.2**, in order to verify if it is possible to capture a more restrictive situation than the one identified by using the hybrid methodology. In loading cases with second order motions for DOF out of horizontal plane, CONTRACTOR shall consider this load parcel using harmonic signals or original random signals (depending on how PETROBRAS provides this data) and compose them with the first order random parcel, without necessity to phase alignment since a longer total time simulation is required. Alternatively, it is possible that PETROBRAS decides to provide complete time traces with first and second order parcels from coupled model time domain simulations.

As critical loading cases, CONTRACTOR shall select from Table 7 or Table 8 the ones that give:

- The highest value of DNV UF at TDZ;
- The highest value of DNV UF at buoyancy modules region (HOG & SAG regions);
- The highest value of DNV UF in the top region;
- Maximum and Minimum FX, FY, FZ, MX, MY, MZ (see reference system described in section 7.1, Figure 7) at the riser top;
- The highest value of compression along the line, if applicable;
- The highest FXJ/ SJ cocking angle.

The EHMP methodology requires the definition of a single reference DOF for each analysis. For this procedure, vertical imposed motion, movZ, shall be always the reference DOF, which affects severely the SAG, HOG and touch down area. For the riser top region design, other degrees of freedom may be

TECHNICAL SPECIFICATION	Nº: I-ET-0000.00-0000-274-P9U-001	REV. H
GENERAL		SHEET: 32 de 72
TITLE: SLWR DETAILED STRUCTURAL DESIGN REQUIREMENTS		EDR
		-

critical, so they may be adopted also as reference DOF, between movX and movY, and between movRX and movRY, depending on analyst judgment if additional loading cases should be performed in order to obtain the most conservative results for the riser.

#### 5.4.1. Equivalent Harmonic Motion Procedure (EHMP)

The following steps shall be followed:

- Transfer the RAO from the FPU center of motion to each riser top connection point;
- Obtain the response spectrum for the motions at each riser top connection point, by crossing the wave spectrum with the RAO transferred to these connections;
- Determine, considering the Rayleigh statistical distribution, the most probable maximum value of displacement ( $d_{max}$ ) and acceleration ( $a_{max}$ ) for each riser top connection point;
- Determine, for each DOF, the dynamic motion period ( $T$ ) at each riser top connection point, using the most probable maximum value of displacement ( $d_{max}$ ) and acceleration ( $a_{max}$ ), as determined in item (c) above, considering the following formula:

$$T = 2\pi \sqrt{\frac{d_{MAX}}{a_{MAX}}}$$

- Assume harmonic motions for each riser top connection point, corresponding to the maximum amplitude values calculated for each DOF, as per item (c) above ( $d_{max}$ ) and a single period evaluated for the reference DOF, according to paragraph (d) above ( $T$ );
- Assume, for the regular motions at each top riser connection point, the same phase values of the transferred RAO in paragraph (a), taken for the corresponding period of paragraph (d).

**Note:** The above approach does not consider the direct wave action on the riser.

#### 5.4.2. Irregular Wave Procedure (IWP)

This procedure shall be considered as a validation check of the results from the above-mentioned EHMP procedure for each riser. Therefore, only the critical loading cases, selected according to section 5.4, shall be analyzed according to this method covering each one of the critical riser regions per riser. Alternative approaches may be proposed for PETROBRAS approval.

- The minimum simulation time shall be 10800s;
- The minimum number of harmonic components to describe wave spectra shall be 300;
- When 2<sup>nd</sup> order motion time-series are provided by PETROBRAS, they are preferable when compared with harmonic signals;
- The peak values obtained from riser analysis in time domain shall be based on an extreme distribution fitting (Gumbel) to determine the maximum DNV-UF and von Mises at 3 critical regions (Top, SAG-HOG and TDZ), maximum/minimum values for the top interface loads and maximum cocking angle, assuming the most probable value;
- The number of realizations (i.e. seed number variation) shall be studied to determine the statistical extreme values. Three procedures can be accepted:



- i. Instead of most probable value, if all parameters described in (d) above meet the criterion for the 3-h extreme value distribution with 90% of non-exceedance, just 1 seed can be performed. Note that 3-h extreme value distribution shall be obtained by firstly fitting a Weibull distribution to the **time series peaks sample** and then using Order Statistics;
  - ii. If parameters described in (d) do not meet the design criteria **with the methodology** described in (i) above, 3-h long simulations for at least 20 seed numbers shall be performed. A Gumbel distribution shall be fitted to the sample containing the maximum/ minimum historical from each realization;
  - iii. Alternatively to (ii), just one realization (1 seed number) with a time duration much longer than 3-h can be performed, but the time duration needs to be long enough to guarantee the statistical stability of mean, standard deviation, skewness and kurtosis of the signal. Based on a stable signal, the peak values would be adjusted as described above in (d) [25].
- f) The complete methodology to be adopted, including number of realizations, time duration of each simulation and determination of extreme values, shall be described at the **Riser Design Premises and Methodology Report**, and submitted to PETROBRAS for approval.

In summary, 3 levels of loading cases (LC) selection are performed during the riser design under extreme loads, reducing progressively their quantity:

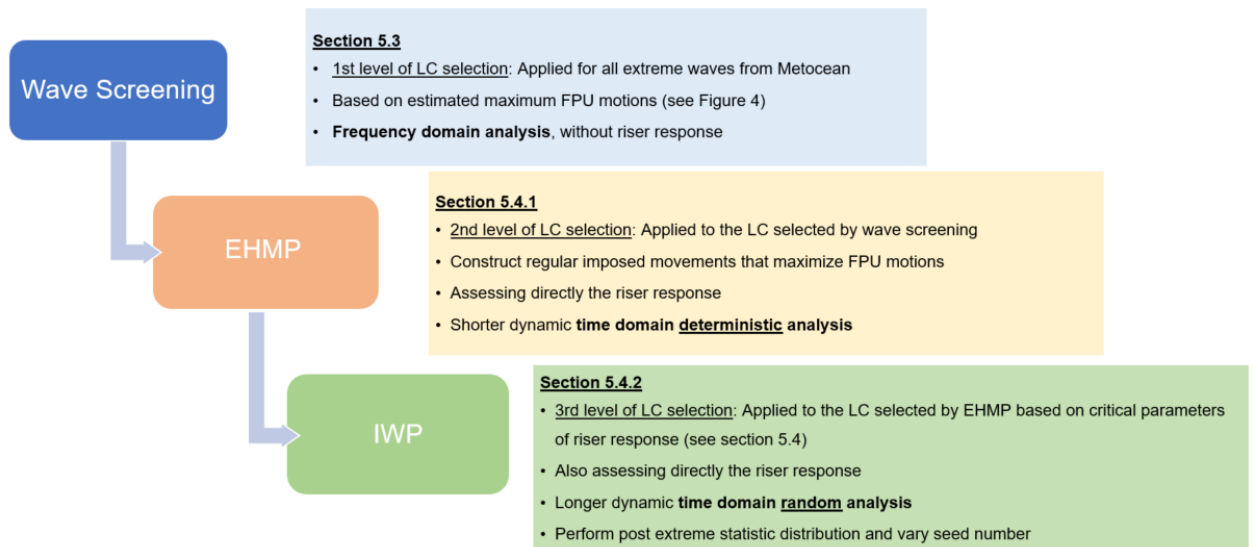

Figure 5 – Levels of loading cases selection per analysis steps

### 5.5. SENSITIVITY ANALYSES

Sensitivity analyses are intended to provide information about the changes in the riser behavior, corresponding to the variation in the input parameters used in the analyses performed. The riser model used in the analyses shall be based on the nominal characteristics, but the effect of variations **needs to be investigated individually**. One exception, however, is when analyzing critical cases that **maximizes top efforts and stresses** which shall be performed together with **FXJ stiffness tolerances** ( $\pm 10\%$ ), as previously described in item 4.4.

<b>TECHNICAL SPECIFICATION</b>	Nº: <b>I-ET-0000.00-0000-274-P9U-001</b>	REV. <b>H</b>
<b>GENERAL</b>		SHEET: <b>34 de 72</b>
TITLE: <b>SLWR DETAILED STRUCTURAL DESIGN REQUIREMENTS</b>		<b>EDR</b>
		<b>-</b>

CONTRACTOR shall select the critical conditions from base case and perform the sensitivity study for the minimum set of parameters described below, at least for the most critical risers selected by each critical region (Top, SAG&HOG and TDZ), i.e. each critical region can come from different riser, per ID or OD, for each riser function, selected according to each parameter defined in section 5.4. Note that for each selected riser, the results shall be presented for its entire riser length (Top, SAG&HOG and TDZ) and per ID and OD. In a case **to have in** the design more than one internal diameter **and/or riser configuration** for the same riser function, each one shall be treated separately, as **per section 4.10**.

The loading cases used in the study shall be the same most critical ones selected for IWP approach.

As a result from the sensitivity analyses, CONTRACTOR can suggest further investigation or limitations to the riser construction in order to mitigate undesirable effects.

**CONTRACTOR shall present in the document of Riser Design Premises and Methodology Report a detailed proposal for the variation of each parameter to be discussed and approved by PETROBRAS.**

The minimum set of parameters to be investigated shall include:

- Riser installation top angle (see reference [1]);
- Riser installation azimuth and/or riser support construction errors (see reference [1]);
- Riser internal fluid density variations for operational and temporary situations (all cases not included as a base case). In case a comprehensively fluid screening study is presented and approved by PETROBRAS, this sensitivity can be disregarded;
- Upper bound hydrodynamic parameter, including the influence of Marine Growth on the top region (even with the anti-fouling coverage) and **Amplified Cd by** DAF along the riser length;
- Pipe weight fabrication tolerances (see reference [26]);
- FXJ rotational stiffness value (tolerances of  $\pm 10\%$  w.r.t. selected curves from base case);
- Error in the buoyancy modules positioning along the riser;
- Variations in the efficiency of the buoyancy modules according to fabrication tolerances per module informed by supplier;
- Soil parameters (upper bound and lower bound parameters).

### **5.6. LIMIT OFFSET FOR 1<sup>st</sup> RISERS PULL-IN**

**To expedite the first oil, CONTRACTOR is required to inform the possibility of the proposed riser system to be installed under a wider range of FPU offsets, performing the pull-in of first risers before the complete mooring lines installed and tensioned.**

**Note that the risers would operate under these temporary conditions only if the results presented are in accordance with all the design criteria required in this technical specification and others referred to herein. Therefore, the results required do not represent an obligation to be met, but an assessment to determine if, within a reduced timeframe at the beginning of the whole project, the riser can operate under these conditions.**

**The required conditions to be analyzed:**

<b>TECHNICAL SPECIFICATION</b>	Nº: <b>I-ET-0000.00-0000-274-P9U-001</b>	REV. <b>H</b>
<b>GENERAL</b>		SHEET: <b>35 de 72</b>
TITLE: <b>SLWR DETAILED STRUCTURAL DESIGN REQUIREMENTS</b>		<b>EDR</b>
		-

- FPU offsets of 16%, 14%, 12%, and 10%;
- Under three conditions: extreme annual waves and weather restriction conditions of 3 meters and 2 meters Hs, with Tp at a peak vessel resonant response, per direction.

The resultant limiting criteria should be clearly identified, including riser, vessel, pull-in rigging and pull-in system limitations.

## 6. FATIGUE ANALYSIS

The objectives are:

- To demonstrate that the riser is designed according to the DNV-RP-C203 [5];
- To evaluate the fatigue damage along the riser, and especially in the critical riser sections, coming from:
  - FPU motion and direct wave action on the riser;
  - Current VIV;
  - Heave-induced VIV motion;
  - Slugging (if applicable).
- To calculate the damages along the riser length for each parcel above and the totalized them, joint by joint (in each correspondent arclength), detailing at least top, buoyancy modules (HOG and SAG regions) and TDZ regions (see restrictions to totalize joint by joint in TDZ for Current VIV and Slugging in item 6.2 and 6.3);
- To define the length and location of critical riser sections, identifying fatigue sensitive and non-fatigue sensitive sections, as mentioned in Table 1 (item 5.19);
- To generate top loads and angular deflections to be used for the specification of the riser top connector;
- To generate top loads to be used in the design of the FPU receptacle and support structure;
- To generate stress histograms to be used in the ECA study of critical riser sections and other joints along the riser (see item (k) below). Thus, it is necessary to inform histograms of totalized damage from all fatigue parcels together and also to inform histograms of each source of fatigue damage separately, choosing the critical joints identified in the totalized damage. The bin size of stress variation in histograms shall be the same for all fatigue parcels. Thus, find an adequate bin size to be employed for all histograms.

The general methodology requirements are listed below:

- a) Fatigue assessment shall be evaluated in sixteen (16) points around the girth weld and parent material along the riser, considering eight (8) points around the riser circumference on the internal wall and eight points around the external wall (see Figure 6);

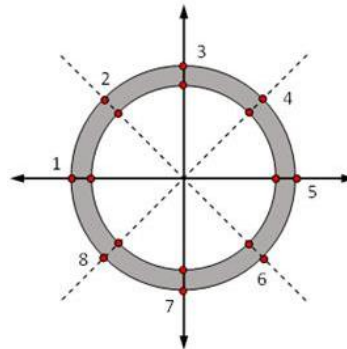

Figure 6 – Points around riser section for fatigue evaluation  
(3-7 riser plane and 1-5 out-of riser plane)

- b) Convenient SCF shall be considered and evaluated for fatigue damage calculation of steel riser critical regions such as the riser girth welds, J-Lay collar, upset-end pipe, etc. The SCF shall be calculated according to the methodology described in reference [5]. The hi-lo shall be assumed as described in Table 1, item 5.12;
- c) For pipes with thickness greater than 25mm, perform a correction in the calculated SCF according to reference [6].
- d) The pipe parent material shall be verified. Depending on the geometrical profile obtained after pipe ends machining (if applicable), a stress concentration may result and shall be considered;
- e) In case of use the upset-end pipe in critical riser regions, CONTRACTOR shall consider an appropriate model to well represent the stresses in these positions. Two approaches may be accepted by PETROBRAS: a detailed representation of the pipe thickness at the upset, including the transition to pipe body or the simplified methodology indicated in Appendix C;
- f) The S-N curves to be adopted will be defined as mentioned in item 5.10 of Table 1;
- g) For aggressive corrosion service, the penalty factors to be applied to S-N curves in C-Mn sections shall be considered, according to the data defined in Table 1, item 5.11;
- h) For in-line forged components, specific SCF and S-N curve shall be used in the fatigue verification as for the welds and parent material;
- i) All internal fluid characteristics provided in section 6.2 of Table 1 shall be considered in the analyses. Alternatively, CONTRACTOR can propose a fluid density screening to select among some group of fluids which ones will provide worst damage conditions to be considered as a base case, covering operational and temporary fluid conditions, and submitted to PETROBRAS for approval. At least one representative minimum, medium and maximum fluid densities and empty condition shall be selected as base case. For risers operating with more than one function, the fluid content for each function associated with respective operating condition shall be included. All fluids not selected as a base case shall be analyzed in sensitivity study. In a lack of information about time duration of each internal fluid [2], a 100% time duration shall be considered for each one.
- j) CONTRACTOR shall adopt for the buoyance modules the EOL condition as a base case, due to soak/compressive/creep effects informed by supplier.

- k) Stress histograms shall be generated for the most critical riser per function and per critical section (note that each critical region may be associated to different risers): sections that present the minimum fatigue lives at the riser top region, at buoyancy modules region (HOG and SAG regions), at the TDZ, at the TRF or Inline Anchor Forging, at all the transition points between clad and lined pipe segments (if applicable) and at all the transition points between fatigue sensitive and non fatigue sensitive segments (if applicable). These stress histograms shall be adopted for all other risers with the same function. In case of very conservative results, CONTRACTOR may additionally generate stress histograms for specific risers to avoid over conservatism.
- l) Two approaches are **required** by PETROBRAS to be applied on the damage summation of all parcels, **and both shall meet the design criteria**:
- **Direct linear summation** Each damage shall be factored by its respective DFF determined in items 5.17 and 5.18 from Table 1.

$$D_{total\ in-plane} = (DFF_1 \times (D_{wave} + D_{Slug}) + DFF_2 \times D_{VIV\ in-plane})$$

$$D_{total\ out-of-plane} = (DFF_1 \times (D_{wave} + D_{Slug}) + DFF_2 \times (D_{VIV\ out-of-plane} + D_{HVIV}))$$

Where:

DFF<sub>1</sub> and DFF<sub>2</sub> are according to items 5.17 and 5.18 from Table 1

D<sub>wave</sub> – damage due to Wave and Motion

D<sub>slug</sub> – damage due to Slug flow

D<sub>VIV</sub> – damage due to VIV current profiles

D<sub>HVIV</sub> – damage due to Heave induced VIV by waves (contributing just for out-of-plane fatigue parcel)

- **Quadratic summation** (according to expression below with DFF of item 5.17 from Table 1), by reference [27].

$$D_{total\ in-plane} = \left( DFF_1 \times \left( D_{wave}^{\frac{2}{m}} + D_{VIV\ in-plane}^{\frac{2}{m}} + D_{Slug}^{\frac{2}{m}} \right)^{\frac{m}{2}} \right)$$

$$D_{total\ out-of-plane} = \left( DFF_1 \times \left( D_{wave}^{\frac{2}{m}} + D_{VIV\ out-of-plane}^{\frac{2}{m}} + D_{HVIV}^{\frac{2}{m}} + D_{Slug}^{\frac{2}{m}} \right)^{\frac{m}{2}} \right)$$

Where:

DFF<sub>1</sub> is according to item 5.17 from Table 1

D<sub>wave</sub> – damage due to Wave and Motion

D<sub>slug</sub> – damage due to Slug flow

D<sub>VIV</sub> – damage due to VIV current profiles

D<sub>HVIV</sub> – damage due to Heave induced VIV by waves (contributing just for out-of-plane fatigue parcel)

*m* – S-N curve slope. If bilinear curve, adopt the most critical *m* value.

<b>TECHNICAL SPECIFICATION</b>	Nº: <b>I-ET-0000.00-0000-274-P9U-001</b>	REV. <b>H</b>
<b>GENERAL</b>		SHEET: <b>38 de 72</b>
TITLE: <b>SLWR DETAILED STRUCTURAL DESIGN REQUIREMENTS</b>		<b>EDR</b>
		-

Graphs of damage comparing linear and quadratic summation along the entire riser shall be presented. Note that the most critical fatigue damage between these two approaches shall be adopted in the combined fatigue summary.

Unfactored fatigue damage shall be presented in documents with the results of each fatigue parcel (see section 10.2.3, 10.2.4 and 10.2.5). Factored fatigue damage, fatigue life and contribution of temporary conditions (as installation budget, wet storage, etc.) shall be presented in document with the combined fatigue summary (see section 10.2.6).

All damages of operational conditions shall be presented in an annual base to properly combine all fatigue parcels. Temporary conditions shall be considered as a budget ( $\beta$ ) in the final calculation of fatigue life, as per the following equation:

$$Fatigue\ life = \frac{(1 - \beta)}{D_{total}}$$

## 6.1. WAVE AND MOTION FATIGUE ANALYSIS

### 6.1.1. Methodology Requirements

- a) The following effects shall be considered in the analysis: the functional loads, the static offset, the wave first and second order FPU motions and the effect of waves and currents acting directly on the riser. First order motions shall be considered at six DOF's; second order motions shall be considered acting simultaneously with the first order motions in surge and sway DOF's. If applicable, still consider second order motions in DOF's out of horizontal plane (heave, roll and pitch);
- b) The relative phase angle between motions and waves direct action over the riser shall be considered in the analyses;
- c) The base case shall consider two most frequent FPU drafts, totalizing for both 100% of time duration.
- d) The time domain random fatigue analysis approach shall be used;
- e) A realistic frequency range shall be considered, containing at least 300 frequency intervals for the wave spectrum discretization;
- f) In order to identify the stress ranges and corresponding number of cycles contained in the predicted stresses time series, the Rainflow method shall be employed;
- g) For the FXJ modeling, see section 4.4, item c) to select appropriate FXJ stiffness;
- h) The fatigue performance for the risers must satisfy the design life through the totalized damage and incorporate the safety factors mentioned in section 6, item l). If CONTRACTOR intends to reduce the safety factor (based on item "Enhanced risk based safety factors – steel risers" from DNV-RP-F204 [6]), the validation study shall be presented to PETROBRAS approval;
- i) The soil stiffness and friction values adopted shall correspond to the medium values associated to an appropriate riser embedment: 25% for extreme loads (as mentioned in section 5, item m)) and 100% for operational loads;

- j) For lined and clad pipes verification, CONTRACTOR shall refer to section 4.3;
- k) The total integration time for each analysis shall be 3-hours, but CONTRACTOR may propose a shorter simulation (not less than 1-h), based on a previous study to be submitted for PETROBRAS approval, with:
- a. Comparison of 3-hours and 1-hour as  $(1h - 3h) \div 3h$ , per loading case, in terms of individual damage and ZZ-stress (mean and standard deviation). 3h is the reference for comparison;
  - b. Considering at least the loading cases that totalize 90% of damage in each critical sections along the riser;
  - c. For the hot-spots from TOP, SAG&HOG and TDZ (even coming from different risers);
  - d. For at least one riser per function.
- l) The base case shall adopt different seed numbers for each loading case [28];
- m) Just for risers with a small fatigue margin (less than 20%), i.e. for the difference between Design life and total combined factored fatigue life, in any hot-spots, additional investigations shall be performed in terms of seed number (minimum of 20 seeds) and 3-hours time duration.

#### 6.1.2. Loading Cases

Wave and Motion Fatigue shall encompass both long term and short term fatigue parcels. These parcels can be linearly combined joint by joint.

As long term, PETROBRAS will provide the complete set of correlated wave, wind and current representing a typical operational year and CONTRACTOR shall analyze all set of data from item 2.1 of Table 1.

- Bi-modal waves shall be employed, according to reference [17].
- For fatigue current profiles, associate the correspondent ones from surface level, considering velocity and direction from each cluster, according to reference [16].
- PETROBRAS will provide the mean offsets, first and second order motions separately or the full motion time traces, according to PETROBRAS choice for the specific design.

As short term, some storm colinear conditions (wave, current and offset) shall also be added to the operational conditions as explained below. For each riser, the most critical extreme waves (and its correspondent current profile, offset and FPSO draft) in terms of fatigue damage at critical regions of riser (TOP, SAG&HOG and TDZ) for ID and OD, for each load category separately (1-year, 10-years and 100-years), shall be used:

- The most damaging loading case for **1-year return seastate** with a percentage of occurrence that corresponds to one occurrence of this storm condition for each one year of Design life (each occurrence with 3-hours duration);

- The most damaging loading case for **10-years return seastate** with a percentage of occurrence that corresponds to one occurrence of this storm condition for each ten years of Design life (each occurrence with 3-hours duration);
- The most damaging loading case for **100-years return seastate** with a percentage of occurrence that corresponds to one occurrence of this storm condition for the Design life, (each occurrence with 3-hours duration).

Two possibilities are accepted for the selection of most damaging loading case, one loading case per each return period described above (1-year, 10-years and 100-years):

- Perform random analyses with IWP approach for all seastates analyzed in section 5.3 (selected by wave screening), for load combinations described in Table 9;
- Identify firstly the most critical direction for damage through the EHMP approach, following Table 9, and perform random analyses with IWP approach for all extreme seastates of the most critical direction, and then select the wave that provides the most damage on riser.

Table 9  
Wave Fatigue Seastates for Storm Conditions

Fatigue Bins	Environment	Extreme Load Combination (**)	Occurrence
Bin 1	1-year seastate	ULS1	1 event for each 1-year duration
Bin 2	10-year seastate	ULS3	1 event for each 10-year duration (*)
Bin 3	100-year seastate	ULS2	1 event for Design life

(\*) To calculate the percentage of occurrence for decenary condition, CONTRACTOR shall always consider entire events, i.e., 10yr, 20yr, 30yr, ..., even without a not complete decade as design life (for example: Required Design life = 23 years shall consider 3 storm events for Bin 2)

(\*\*) All fluids analyzed in **fatigue** base case for each load combination (ULS1, ULS2 and ULS3). **Note that ULS1 condition is a reference for extreme annual load combination, but all fatigue base case fluids shall also be analyzed for this condition.**

### 6.1.3. Sensitivity Analysis

Sensitivity analyses are intended to provide information about the changes in the riser behavior, corresponding to the variation in the input parameters used within the analyses performed. The riser model used in the analyses shall be based on the nominal characteristics, but the effect of variations needs to be investigated individually.

CONTRACTOR shall select the critical conditions from base case and perform the sensitivity study for the minimum set of parameters describe below, at least for the most critical risers selected by critical regions (Top, SAG&HOG and TDZ), i.e. each critical region can come from different riser, per ID or OD, for each riser function, in terms of fatigue life, as exemplified in Table 10. Note that for each selected riser, the results shall be presented for its entire riser length (Top, SAG&HOG and TDZ) and per ID and OD. In a case to have in the design more than one internal diameter **and/or riser configuration** for the same riser function, each one shall be treated separately, as **per section 4.10.**



Table 10  
Example of most critical conditions to perform sensitivity

Riser Functions	Diameter	TOP	SAG&HOG	TDP
PROD	ID	Slot: A Fluid code: X1 FPSO draft: LCY1	Slot: B Fluid code: X2 FPSO draft: LCY2	Slot: C Fluid code: X3 FPSO draft: LCY3
	OD	Slot: D Fluid code: X4 FPSO draft: LCY4	Slot: E Fluid code: X5FPSO draft: LCY5	Slot: F Fluid code: X6FPSO draft: LCY6
INJ	ID	Slot: A Fluid code: X1 FPSO draft: LCY1	Slot: B Fluid code: X2 FPSO draft: LCY2	Slot: C Fluid code: X3 FPSO draft: LCY3
	OD	Slot: D Fluid code: X4 FPSO draft: LCY4	Slot: E Fluid code: X5 FPSO draft: LCY5	Slot: F Fluid code: X6 FPSO draft: LCY6

(\*) Slot, fluid code and FPU draft can be the same or not between riser regions and pipe wall.

In terms of most critical loading cases, two steps may be applied to select a reduced number of simultaneous metocean conditions in the sensitivity study:

1. Perform the minimum set of parameters described below, initially with the loading cases that totalize 50% of damage, in each one of critical sections along the riser. In case of the new results surpass in 5% and 60% the fatigue life of the base case (with the same set of loading cases) for fatigue sensitive and for non fatigue sensitive riser regions respectively (see item 5.19 from Table 1), additional verifications shall be performed according to item (2) below. For each selected riser, combine for the entire riser the critical load cases of all critical regions.
2. For the parameters that exceed the fatigue life limits specified in item (1) above, a more detailed analyses shall be performed, at least with the loading cases that totalize 90% of damage in each one of critical sections along the riser. For each selected riser, combine for the entire riser the critical load cases of all critical regions.

One exception for the above criteria is for internal fluid density variations, where at least the loading cases that totalize 99% of damage shall be analyzed for the most critical risers per function and per critical regions.

As a result from the sensitivity analyses, CONTRACTOR can suggest further investigation or limitations to the riser construction in order to mitigate undesirable effects.

**CONTRACTOR shall present in the document of *Riser Design Premises and Methodology Report* a detailed proposal for the variation of each parameter to be discussed and approved by PETROBRAS.**

The minimum set of parameters to be investigated shall include:

- Riser installation top angle (see reference [1]);

- Riser installation azimuth and/or riser support construction errors (see reference [1]);
- Riser internal fluid density variations for operational and temporary situations (all cases not included as a base case);
- Analyses without application of current profiles, or the current profile with the minimum surface velocity for the same direction of each load case selected as critical;
- Variations on hydrodynamic coefficients, including lower and upper bound values;
- Pipe fabrication tolerances (see reference [26]);
- FXJ rotational stiffness value (tolerances of  $\pm 10\%$  w.r.t. selected curves from base case);
- Accidental loss of buoyancy modules (see Table 5);
- Error in the buoyancy modules positioning along the riser;
- Variations in the efficiency of the buoyancy modules according to fabrication tolerances per module informed by supplier;
- Soil parameters (upper bound and lower bound parameters).

## 6.2. VIV FATIGUE ANALYSIS

The objectives are:

- To define the VIV suppressor type, length and positioning along the riser;
- To guarantee the adequate level of safety, based on the characteristics of the products being purchased and qualified for the installation;
- To evaluate the fatigue damage along the riser, mainly in the buoyancy region (SAG and HOG regions) and TDZ, coming from the **action of currents** that causes vortex induced vibration;
- To evaluate the fatigue damage along the riser, mainly in the top region, buoyancy region (SAG and HOG regions) and TDZ, coming from the **action of FPU motion** that causes vortex induced vibration (heave induced fatigue);
- To generate the stress histograms to be used in the calculation of total damage with the addition of all effects that causes fatigue;
- The fatigue performance for the risers must satisfy the design life through the totalized damage, incorporating the safety factors, mentioned in section 6, item I).

### 6.2.1. Current VIV Fatigue Analysis

- a) Sheared-flow effects shall be considered;
- b) The program SHEAR7 from MIT (Massachusetts Institute of Technology) shall be used (see section 4.9). If considered by CONTRACTOR the use of other computer codes, it shall be submitted to PETROBRAS for approval;

<b>TECHNICAL SPECIFICATION</b>	Nº: <b>I-ET-0000.00-0000-274-P9U-001</b>	REV. <b>H</b>
<b>GENERAL</b>		SHEET: <b>43 de 72</b>
TITLE: <b>SLWR DETAILED STRUCTURAL DESIGN REQUIREMENTS</b>		<b>EDR</b>
		-

- c) The SHEAR7 steering parameters such as Strouhal number, CL tables, cut-off, reduced velocity bandwidth, structural damping and others, shall be listed in the **Riser Design Basis Report** and submitted to PETROBRAS for approval;
- d) The VIV analyses shall consider the riser mode shapes and curvatures in the riser static neutral configuration, including the representation of each buoyancy module individually, a proper soil stiffness at the TDZ and soil bathymetry between TDP and TRF;
- e) In the analyses, all current profiles (see documents [16] and [17]) shall be considered as aligned along the water depth. It means that the individual direction associated to each depth level shall not be considered. The current profiles shall be considered as unidirectional for VIV analysis purpose. All single current profiles shall be considered as acting in two different directions: in-plane and out-of-plane (without performing any velocity projection). This means that each current profile shall be aligned with the riser plane and also perpendicular to the riser plane;
- f) The VIV analysis of the riser shall be performed for two types of loads, namely: short-term VIV analysis (extreme) and long-term VIV analysis (common operation). The short-term events fatigue damage shall be added to the long-term event fatigue damage;
- g) The short-term VIV analysis will determine the damage induced by the extreme currents of all directions and reference levels of document [17]. CONTRACTOR shall perform these analyses considering two types of events: 10-years return period events and 100-years return period events. These events are composed by an evolution of current profiles in each direction: “1-year to 100-years to 1-year” and “1-year to 10-years to 1-year”. The duration of each current profile in all directions will be defined in document [17]. It shall be assumed that during the Design life the riser will see one 100-years event and n-times 10-years event (follow the same approach described in Table 9 for the quantity of decenary events).
- h) To combine 100-years and 10-years events for fatigue damage, CONTRACTOR shall identify: the most damaged 100-year direction to compose one event of 100-years duration (with all profiles from that direction); the most damaged 10-year direction to compose one event of 10-years duration (with all profiles from that direction, considered n-times during the Design life, as described above). The damages, for the most critical direction, for each type of event, will be added to the long-term fatigue damage, assuming the duration described in the following documents: [16] for long-term current profiles and [17] for short-term current profiles;
- i) The long-term events correspond to the whole set of currents with return period of less than 1-year. CONTRACTOR shall use in the analyses all this set of current, including all Reference Level Profiles and directions, as per [16];
- j) Each long-term current profile has a number of occurrence, and their percentage of occurrence is determined dividing this number of occurrence by the total quantity of occurrence from all current profiles for all reference levels and directions;
- k) Fatigue damage values coming from the complete set of current profiles are usually added considering the TDP on the same position due to the frequency domain analysis. In this context, the most critical damage from TDP shall be considered as acting in the entire TDZ region as a baseline\* for the total damage summation joint by joint. If this approach become very conservative for TDZ, CONTRACTOR can assume a TDP damage spreading based on the TDP positions from Wave and Motion fatigue analysis, as presented in Appendix D, but still considering a new lowered

baseline from the most critical TDP damage. If CONTRACTOR intends to present a different proposal for TDP damage spreading, it shall be submitted to PETROBRAS for approval;

\*(baseline defined in an extension to cover the maximum near and far riser TDP positions from the extreme load cases, the same identified in TDP footprint from extreme analysis).

- l) CONTRACTOR shall calculate VIV damage at external and internal fibers of the riser sections; The soil stiffness and friction values adopted shall correspond to the medium values associated to an appropriate riser embedment: 25% for short-term (extreme loads) and 100% for long-term (operational loads).
- m) The same fluids selected as base case through the fluid screening of Wave and Motion Fatigue Analysis (see section 6, item i)) shall be adopted for Current VIV.

### 6.2.2. Heave Induced VIV Fatigue Analysis

- a) The effect of heave induced VIV shall be investigated, with respect to the damage in the critical regions along the riser: Top, SAG&HOG and TDZ;
- b) All loading cases selected for Wave and Motion fatigue analysis, including the extreme waves, (defined in section 6.1.2) shall be analyzed to the heave induced VIV;
- c) In principle, all Wave fatigue loading cases shall generate normal velocity significant value ( $2 \cdot \text{RMS}$ ), that will be used to compose a current profile to be applied in the SHEAR7 analyses;
- d) Time domain analysis shall be used for the evaluation of the equivalent current profiles;
- e) The duration of the extreme events shall be the same assumed for the Wave fatigue calculations as mentioned in section 6.1.2;
- f) CONTRACTOR may propose alternative approaches or changes in the herein stated methodology in order to evaluate the damage contribution from the Heave Induced VIV that shall be submitted to PETROBRAS for approval;
- g) The soil stiffness and friction values adopted shall correspond to the medium values associated to an appropriate riser embedment: 25% for short-term (extreme loads) and 100% for long-term (operational loads).

### 6.2.3. Sensitivity Analysis

Sensitivity analyses are intended to provide information about the changes in the riser behavior, corresponding to the variation in the input parameters used within the analyses performed, **for long and short terms**. The riser model used in the analyses shall be based on the nominal characteristics, but the effect of variations needs to be investigated individually.

CONTRACTOR shall select the critical conditions from base case and perform the sensitivity study for the minimum set of parameters described below, at least for the most critical risers selected by critical regions (SAG&HOG and TDZ), i.e. each critical region can come from different riser, per ID or OD, for each riser function, in terms of fatigue life, as exemplified in Table 10 (disregarding the top region and

parameter of FPSO draft, not relevant to VIV). Note that for each selected riser, the results shall be presented for its entire riser length (Top, SAG&HOG and TDZ) and per ID and OD. In a case to have in the design more than one internal diameter **and/or riser configuration** for the same riser function, each one shall be treated separately, as **per section 4.10**.

- For VIV, the most critical loading cases shall be:
  - for long-term: all load cases, but just for in-plane or out-of-plane vibration, whichever is more critical;
  - for short-term: the same critical events already selected for 100-years event and 10-years event.
- For HVIV, its not necessary to perform sensitivity study.

As a result from the sensitivity analyses, CONTRACTOR can suggest further investigation or limitations to the riser construction in order to mitigate undesirable effects.

**CONTRACTOR shall present in the document of *Riser Design Premises and Methodology Report* a detailed proposal for the variation of each parameter to be discussed and approved by PETROBRAS.**

The minimum set of parameters to be investigated shall include:

- Lift and added mass coefficients;
- Suppressors coverage (length and positions);
- SHEAR7 steering parameters;
- Soil parameters (upper bound and lower bound parameters);
- Accidental loss of buoyancy modules (see Table 5);
- Accidental loss of **VIV suppressor** on top, near SAG&HOG (if applicable), between TDP and HOG (if applicable) **and on TDZ (if applicable)**, each one in an individual analysis;
- Error in the buoyancy modules positioning along the riser;
- Riser internal fluid density variations for operational and temporary situations (the same included in the sensitivity of Wave and Motion fatigue analysis);
- Pipe fabrication tolerances (see reference [26]);
- Mode shapes and curvatures for maximum far and near offsets and the consequences for fatigue life.

### 6.3. SLUGGING EFFECT ANALYSIS

A structural evaluation of the effect of slugging (hydrodynamic and/or severe) on the production risers for Fatigue Analyses results shall be performed when applicable.

<b>TECHNICAL SPECIFICATION</b>	Nº: <b>I-ET-0000.00-0000-274-P9U-001</b>	REV. <b>H</b>
<b>GENERAL</b>		SHEET: <b>46 de 72</b>
TITLE: <b>SLWR DETAILED STRUCTURAL DESIGN REQUIREMENTS</b>		<b>EDR</b>
		-

Fluid slugging characteristics will be provided by PETROBRAS as described in Table 1, item 6.3 or 6.4. All slug loading cases shall be analyzed as base case.

In the particular case of severe slugging, some recommendations shall be followed by CONTRACTOR:

- Selection in the time history of stress bending moment of critical riser region, the portion of permanent signal to be repeated along one typical year, disregarding the transient portion through a cutoff;
- An adequate compatibility in time and space shall be performed:
  - Time: the same time step between the fluid data provided and riser structural model;
  - Space: between the fluid mesh data and riser structural mesh, presenting a sensitivity study for the structural mesh, to be approved by PETROBRAS.
- Care shall be taken with each riser soil bathymetry and its consistence with the flow assurance generated data.

The Slugging fatigue damage shall be properly added to the other fatigue parcels. In the same way as Current VIV, where the critical joint on TDP position is not spread by the FPSO offsets and low frequency motions in horizontal plane, the damage shall be considered as a baseline\* by the most critical damage, where a spread is also allowed to be adopted as presented in Appendix D for Current VIV.

*\*(baseline defined in an extension to cover the maximum near and far riser TDP positions from the extreme load cases).*

The parameters and techniques regarding fatigue calculations shall be in accordance with section 6.

The histograms for ECA regarding slugging effect shall be presented.

### 6.3.1. Sensitivity Analysis

Sensitivity analyses are intended to provide information about the changes in the riser behavior, corresponding to the variation in the input parameters used within the analyses performed. The riser model used in the analyses shall be based on the nominal characteristics, but the effect of variations needs to be investigated individually.

CONTRACTOR shall select the critical conditions from base case and perform the sensitivity study for the minimum set of parameters described below, at least for the most critical riser per critical region, per ID or OD, in terms of fatigue life. In a case to have in the design more than one internal diameter **and/or riser configuration** for the production riser function, each one shall be treated separately, as **per section 4.10**.

The critical loading cases shall be analyzed in the sensitivity study.

TECHNICAL SPECIFICATION	Nº: I-ET-0000.00-0000-274-P9U-001	REV. H
GENERAL		SHEET: 47 de 72
TITLE: SLWR DETAILED STRUCTURAL DESIGN REQUIREMENTS		EDR
		-

CONTRACTOR can suggest further investigation or limitations to the riser construction in order to mitigate undesirable effects.

**CONTRACTOR shall present in the document of *Riser Design Premises and Methodology Report* a detailed proposal for the variation of each parameter to be discussed and approved by PETROBRAS.**

The minimum set of parameters to be investigated shall include:

- Near and Far maximum FPU position, changing the TDP position;
- Accidental loss of buoyancy modules (see Table 5);
- Pipe fabrication tolerances (see reference [26]).

## 7. INTERFACE LOADS

### 7.1. TOP INTERFACE LOADS

The riser top force reactions at the FPU connections for riser balcony and supports structural verifications will be provided by CONTRACTOR, based on the final proposed SLWR configurations of the project. These forces shall be calculated for all riser slots and compared with the limit requirement provided by PETROBRAS for all degrees of freedom, in order to guarantee that the design of the riser balcony and supports at the FPU will be in accordance with the risers final design. For the comparison of maximum riser loads with final limits defined by FPU, a transfer on the load application point shall be performed, according to reference [31] where the application point adopted by FPU is defined.

The main analyses to be performed are:

- Extreme Loading Analysis
- Wave and Motion Fatigue Analysis

The structural global models shall be the same used in the Extreme Combined Load Effect analysis (according to section 5) and Wave and Motion Fatigue Analysis (according to section 6.1). Special attention shall be taken with the reference system for riser top support loads calculation. A fixed reference system at the support shall be adopted and will be called *Support Reference System*, supposing to follow motions from the platform and is independent from the riser motions.

A reference system (e.g. as indicated in Figure 7) shall be followed to present the results, independent of the top connector type, with a fixed axis in the axial direction (e.g. X-axis:  $F_x$ ,  $M_x$ ) when the riser is in the neutral position, coincident with support inclination in the riser direction (sometimes support inclination doesn't coincide with riser top angle, but support inclination is mandatory for the definition of X-axis). The other fixed axes shall coincide respectively with the riser in-plane (e.g. Z-axis:  $F_z$ ,  $M_z$ ) and out-of-plane (e.g. Y-axis:  $F_y$ ,  $M_y$ ) directions. The reference system shall be clearly described in the design documents. The origin of the reference system (depending on the top connector type [19], [20], [21] and [22]) shall be informed.

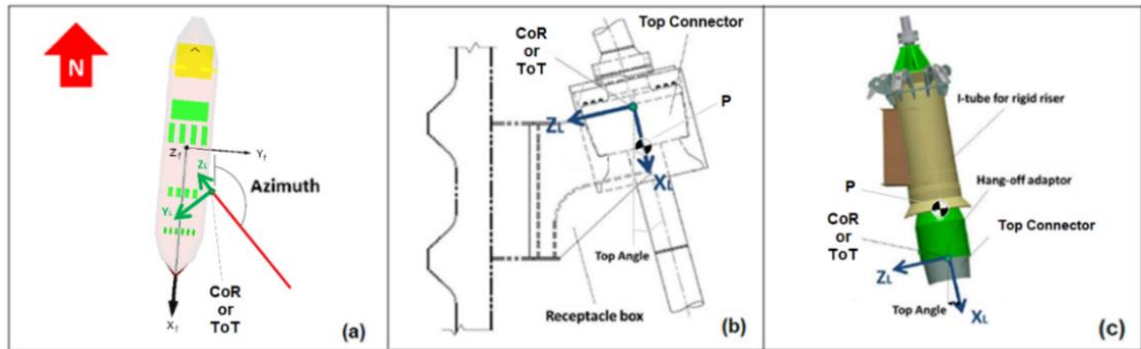

Figure 7 – EXAMPLE of Definition of the Fixed Support Reference System,  
 (a) Top view (b) Lateral view with conical receptacle and (c) Lateral view with hang-off adaptor

### 7.1.1. TOP LOADS BY EXTREME LOADING ANALYSIS

CONTRACTOR shall present the top loads corresponding to all load combinations from Table 3. For each load combination, CONTRACTOR shall present the dynamic **maximum absolute load's resultants** (effective tension ET, bending moment BM and shear force SF) AND **maximum and minimum forces and moments of each component** ( $F_x$ ,  $F_y$ ,  $F_z$ ,  $M_x$ ,  $M_y$  and  $M_z$ ) with their simultaneous, all of them with **riser empty and the heaviest fluid condition**, following the reference system described in section 7.1. The comparison of these top riser loads with the final load limits in terms of maximum resultants or components will depend on what will be available by FPU report, but both shall be presented by CONTRACTOR.

Figure 8 and Figure 9 shows a standard model to be followed by CONTRACTOR to present the riser top interface loads, in terms of resultants and components respectively. For Figure 9, the same load categories presented in Figure 8 shall be assessed. Each value on diagonal shall present the maximum or minimum value of each load parameter and in the other columns their associated values at the same instant of time. The loading case (LC) of each line from table shall be identified. These maximum values to be compared to the load limits shall be in terms of envelope of EHMP and IWP results, whichever is greater, including sensitivity results and, in case of IWP, also including extreme statistical distribution and number of realizations.

Those values shall be identified considering their algebraic values, bringing the signals. In addition to the Dynamic loads (with Functional loads, offsets, current profiles and waves), CONTRACTOR shall also present the Functional loads (Loads that occur as a consequence of the physical existence of the system) and Static loads (with Functional loads, offsets and current profiles).



Load Category	Critical case	Identify Load Case	Effective Tension	Bending Moment	Shear Force
<b>100yr Loads</b> ULS2/ ULS3/ ALS1/ ALS2/ ALS4/ ALS5	LC from Max ET	A	Max Value	Associated value	Associated value
	LC from Max BM	B	Associated value	Max Value	Associated value
	LC from Max SF	C	Associated value	Associated value	Max Value
<b>1yr Operational</b> ULS1/ <b>ULS5</b>	LC from Max ET	A	Max Value	Associated value	Associated value
	LC from Max BM	B	Associated value	Max Value	Associated value
	LC from Max SF	C	Associated value	Associated value	Max Value
<b>1yr Damage Loads to Portside</b> ALS3A/ ALS3C	LC from Max ET	A	Max Value	Associated value	Associated value
	LC from Max BM	B	Associated value	Max Value	Associated value
	LC from Max SF	C	Associated value	Associated value	Max Value
<b>1yr Damage Loads to Starboard</b> ALS3B/ ALS3D	LC from Max ET	A	Max Value	Associated value	Associated value
	LC from Max BM	B	Associated value	Max Value	Associated value
	LC from Max SF	C	Associated value	Associated value	Max Value

Figure 8 – Standard model to report riser top interface loads in terms of resultants

Critical case	Identify Load Case	Max Fx	Max Fy	Max Fz	Max Mx	Max My	Max Mz	Min Fx	Min Fy	Min Fz	Min Mx	Min My	Min Mz
LC from Max Fx	A	Max V	AV	AV	AV	AV	AV	-	-	-	-	-	-
LC from Max Fy	B	AV	Max V	AV	AV	AV	AV	-	-	-	-	-	-
LC from Max Fz	C	AV	AV	Max V	AV	AV	AV	-	-	-	-	-	-
LC from Max Mx	D	AV	AV	AV	Max V	AV	AV	-	-	-	-	-	-
LC from Max My	E	AV	AV	AV	AV	Max V	AV	-	-	-	-	-	-
LC from Max Mz	F	AV	AV	AV	AV	AV	Max V	-	-	-	-	-	-
LC from Min Fx	G	-	-	-	-	-	-	Min V	AV	AV	AV	AV	AV
LC from Min Fy	H	-	-	-	-	-	-	AV	Min V	AV	AV	AV	AV
LC from Min Fz	I	-	-	-	-	-	-	AV	AV	Min V	AV	AV	AV
LC from Min Mx	J	-	-	-	-	-	-	AV	AV	AV	Min V	AV	AV
LC from Min My	K	-	-	-	-	-	-	AV	AV	AV	AV	Min V	AV
LC from Min Mz	L	-	-	-	-	-	-	AV	AV	AV	AV	AV	Min V

(\*) Max V = maximum value    Min V = minimum value    AV = associated value

Figure 9 – Standard model to report riser top interface loads in terms of components

In case of FXJ, for each critical loading case selected by IWP approach (loading cases for maximum and minimum forces and moments in 6 dof and maximum cocking angle), according to section 5, CONTRACTOR shall generate the pairs Tension x Top Angle for each time step, in order to construct

TECHNICAL SPECIFICATION	Nº: I-ET-0000.00-0000-274-P9U-001	REV. H
GENERAL		SHEET: 50 de 72
TITLE: SLWR DETAILED STRUCTURAL DESIGN REQUIREMENTS		EDR
		-

plots that will allow the visualization of the most critical Tension x Top Angle pairs. The methodology accepted to generate the Tension x Top Angle pairs is Irregular Wave Procedure (IWP) in time domain.

In case of SJ and TiPT, the same type of plot shall be generated in terms of Tension x Angle.

Attention shall be taken with the note (\*4) from Table 7 and note (\*3) from Table 8.

Figure 10 shows an example of the plot that needs to be generated. The same scale of axes shall be adopted for all plots generated for the loading cases selected. Loading cases selected for maximum and minimum of the same degree of freedom can be plotted in the same graph.

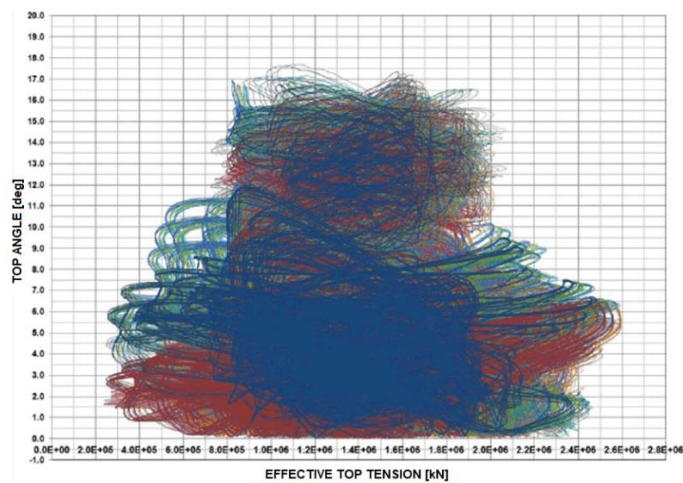

Figure 10 – Plot example of Tension x Top angle

### 7.1.2. TOP LOADS BY WAVE AND MOTION ANALYSIS

The riser top loads to perform fatigue verification of platform hull, receptacle and support structures are calculated based on riser top forces and moments time-series obtained in the wave fatigue analysis, according to section 6.1. For each loading case simulated, it is necessary to generate time-series of each **load** component (Fx, Fy, Fz, Mx, My and Mz) on riser top connection point, and present the statistical values of each component (mean value, standard deviation, maximum and minimum historical, maximum and minimum statistical). The reference system shall be in accordance with the description provided in section 7.1, and same adopted for 7.1.1.

Alternatively to the entire riser scope, the time-series of top efforts under fatigue conditions could be generated at least for the most critical risers per function in each three regions of riser balcony: bow, middle and stern. If present in the subsea layout risers going to portside and starboard, both shall be selected as a minimum scope of their corresponding region of riser balcony. This riser's selection shall be submitted to PETROBRAS for approval.

<b>TECHNICAL SPECIFICATION</b>	Nº: <b>I-ET-0000.00-0000-274-P9U-001</b>	REV. <b>H</b>
<b>GENERAL</b>		SHEET: <b>51 de 72</b>
TITLE: <b>SLWR DETAILED STRUCTURAL DESIGN REQUIREMENTS</b>		<b>EDR</b>
		-

## 7.2. BOTTOM INTERFACE LOADS

The riser bottom force reactions for structural ILA and TRF verification will be provided by CONTRACTOR, based on the final proposed SLWR configurations of the project. The effective tension shall be calculated for all riser azimuths, in order to guarantee that the design of the subsea equipment will be in accordance with the final riser design.

Note that bending moment and shear force are not expected in ILA and TRF positions, as per third requirement from section 4.10, showing this attendance through graphs on this region. CONTRACTOR shall also inform the minimum and maximum length of riser on seabed, with attention to the fourth requirement from section 4.10.

In terms of riser dynamics, the main analysis to be performed is Extreme Combined Load Effect (section 5). The same structural global models used for top interface loads shall be adopted for bottom interface loads, but in terms of bottom reference system, the riser axial axis shall be adopted to present the results. The envelope of maximum and minimum values per load combination shall be presented for EHMP and IWP approaches, whichever is greater. For IWP, all results generated in 5.4.2, including extreme distribution and number of realizations shall be presented for bottom interface loads.

If there is no anchoring system at TRF, additional analyses shall be performed by CONTRACTOR in order to determine the extreme load envelope as well as the cyclic loads which pipeline can impose on PLET. In addition to riser analysis results, loadings refer to operational conditions, such as shutdowns, restarts, etc. shall be considered in these additional analyses. Proper pipe-soil interaction parameters shall be adopted for assuring a certain conservatism level of these analyses. Finally, CONTRACTOR shall previously issue complete methodology for verification and PETROBRAS approval.

## 8. INTERFERENCE ANALYSIS

The methodology and requirements to perform Interference Analyses will be described in document [13].

The drag amplification factor (DAF) for rigid, flexible and umbilicals risers due to VIV effect shall be generated as described in reference [13] for check the clashing between risers, as well between risers and mooring lines.

## 9. INSTALLATION ANALYSIS

The methodology and requirements to perform Riser Installation Analyses will be described in document [14].

In cases where Pre-lay, Wet Storage (WETS) and Recovery is required, the riser design shall encompass fatigue, extreme and interference analyses considering these new riser conditions, in addition to the requirements from documents [14] and [32].

## 10. DELIVERABLES

The CONTRACTOR shall issue a number of design reports related with specific events described below, following a presentation format and time scheduled in agreement with PETROBRAS representatives, before the beginning of the work specified herein.

These reports shall be presented digitally for PETROBRAS comments. The CONTRACTOR shall use the following documentation software: Microsoft®: Word for Windows as word processor converting to Adobe® Portable Document Format (PDF); Excel for Windows as spreadsheet (all calculations related to damage summation, application of any factor, weighting for drafts or any other similar, shall be available in spreadsheets for conference); and Project for Windows as time schedule software. Drawings shall be presented in: MicroStation® for Windows from Bentley Systems native format files (DGN) or Adobe® Portable Document Format (PDF).

Every event will be associated with a report issued by the CONTRACTOR. The main reports are:

- **Riser** Design Basis Report
- **Riser** Design Premises and Methodology Report
- **Riser** Design Summary Report
- **Riser Configuration Data Sheet**
- **Riser** Extreme Combined Load Effect Analysis Report
- **Riser** Top and Bottom Interface Loads Report
- **Riser** Wave and Motion Fatigue Analysis Report
- **Riser** VIV Fatigue Analysis Report
  - Current VIV Fatigue Analysis
  - Heave-Induced VIV Fatigue Analysis
- **Riser** Slugging Analysis Report
- **Riser Combined** Fatigue Analysis Summary Report
- **Riser Efforts at Monitoring System Report**
- **Riser** Interference Analysis Report (see reference [13])
- **Riser** Installation Analysis Report (see reference [14])

The reports shall contain at least the information described in following items.

### 10.1. GENERAL DELIVERABLES

The reports considered as general deliverables are:

- **Riser** Design Basis Report
- **Riser** Design Premises and Methodology Report
- **Riser** Design Summary Report

#### 10.1.1. **Riser** Design Basis Report

This report shall detail and describe all final data involved in riser design such as pipe, coating, buoyancy modules, strakes, top riser connector, riser monitoring system, cathodic protection (directly from the suppliers), the riser system description (layout and configurations), the internal fluid density, pressure and temperature, the FPU data, soil data, environmental data and the riser analysis input data.

Appendix D of DNV-ST-F201 may be used as a guide for Design Basis.

The **Riser** Design Basis Report shall be agreed with PETROBRAS representatives.

#### 10.1.2. **Riser** Design Premises and Methodology Report

This report shall detail and describe the methodologies, procedures and applied computer programs used in steel riser analyses for all riser design criteria; the acceptance criteria to be used; all applicable loading cases, limit states and safety classes for all temporary, operating and accidental design conditions.

The **Riser** Design Premises and Methodology shall be agreed with PETROBRAS representatives.

#### 10.1.3. **Riser** Design Summary Report

This report shall contain the full description of the steel riser configuration and the consolidation of all final results obtained. A summary of each topic and an overall diagnostic of the riser design shall be provided.

### 10.2. SPECIFIC TOPIC DELIVERABLES

The delivered specific topic reports are described in detail in following items. In all these documents with riser analysis results, CONTRACTOR shall become available the complete models employed in all software packages from Table 2.

#### 10.2.1. **Riser** Extreme Combined Load Effect Analysis Report

This report shall include at least the following information described below:

- a) The complete data used in the analyses containing all the details of the riser model and the load data as well, including safety class;

- b) Full traceability of the calculations performed;
- c) Full description of statistical treatment adopted for EHMP and IWP;
- d) The wave spectrum discretization adopted;
- e) The FXJ stiffness used for each simulated loading case;
- f) Tabulated results from functional & static loading cases (with offsets and current static analyses) and from dynamic loading cases (for both approaches EHMP and IWP). The results shall be given to the riser top region, buoyancy modules region (SAG and HOG) and TDZ region of the riser configuration separately, for each riser position, for ID and OD, for each fluid density considered as a base case;
- g) The tabulated results shall include at least: the loading case, the riser imposed top motions and rotations, envelopes of FXJ rotations, axial forces, effective tensions, hoop, bending moments, DNV UF and von Mises stresses along the riser for all critical sections and all riser positions. Static parcel of results shall be presented separately from the dynamic parcel;
- h) For the random time domain analysis, all statistical parameters (mean value, standard deviation, skewness and kurtosis), extrapolated and historical extreme values, shall be tabulated. The complete set of all risers results can be put in the report Appendix section, but the most critical results of each riser shall be highlighted in the main text body;
- i) Graphical results shall be presented for the most critical loading cases of each riser as listed below:
  - Mean or neutral static configuration;
  - Effective tension along the riser in the mean or neutral position;
  - Bending moment along the riser for the mean or neutral position;
  - Envelopes of maximum and minimum effective tension along the riser;
  - Envelopes of maximum and minimum bending moment along the riser;
  - Envelopes of maximum von Mises stresses along the riser;
  - Envelopes of maximum DNV UF along the riser;
  - Time traces for the critical node in the top region, buoyancy modules region (SAG and HOG) and TDZ region for: DNV UF, maximum stresses and minimum effective tension;
  - Static parcel of results shall be presented in the same graphics of dynamic parcel;
  - Time traces with statistical stability of parameters mean value, standard deviation, skewness and kurtosis for IWP approach.
- j) Results from sensitivity analyses;
- k) Time traces, statistical parameters and peak values of the imposed motions and riser response found in the irregular wave analyses for each riser;
- l) The riser TDP footprint calculated for all riser positions. The results shall be presented graphically and also by indicating precisely the distances values for each riser;
- m) For some results, a model of graphics presentation shall be followed and will be provided by PETROBRAS;
- n) An appendix with all complete results along the riser length, including base case and sensitivity.

TECHNICAL SPECIFICATION	Nº: I-ET-0000.00-0000-274-P9U-001	REV. H
GENERAL		SHEET: 55 de 72
TITLE: SLWR DETAILED STRUCTURAL DESIGN REQUIREMENTS		EDR
		-

- o) A separate appendix with risers response evaluation for pull-in limiting conditions under temporary offsets, as per section 5.6, clearly identifying the limiting criteria for risers, vessel, pull-in rigging and pull-in system.

### 10.2.2. Riser Top and Bottom Interface Loads Report

The results report shall include at least the following information described below:

- a) The complete data used in the analyses containing all the details of the riser model and the loading data as well;
- b) Filenames shall have the same root names of the loading cases table, in order to facilitate the record tracking procedure.
- c) Tabulated envelope of interface loads to the top and bottom maximum and minimum reactions of the riser configuration shall be presented separately for: functional & static loading cases (with offsets and current static analyses) and dynamic loading cases (for both approaches EHMP and IWP); all loading combinations (identifying the critical loading case); all riser positions; all fluid densities considered as a base case. The correspondent riser imposed top motions & rotations shall also be reported together with the top reactions, as well the FXJ stiffness adopted;
- d) The comparison of the envelope of top loads with the FPU load limits in terms of maximum resultants and/or components, as per Figure 8 and Figure 9.
- e) For random time domain analysis with IWP approach, all statistic parameters (mean value and standard deviation) extrapolated and historical extreme maximum and minimum values shall be tabulated. Time traces for riser top and bottom reactions shall be provided. The complete set of all riser results shall be presented in an Appendix section and the most critical results be highlighted in the main text body.
- f) The forces and moments at the top shall be provided in a specific load application point and in a fixed reference system as described in section 7.1;
- g) Results from sensitivity analyses;
- h) Graphs with pairs Tension x Top Angle by IWP shall be presented as described in item 7.1;
- i) The tabulated results mentioned in item (c) and pairs Top Tension x Top Angle shall also be provided in Excel spreadsheet file;
- j) Time traces of each component of top forces and moments, statistical parameters and peak values due to Wave and Motion Fatigue Analyses described in item 7.1.2, for riser top connection points selected and each internal fluid density from base case shall be generated.
- k) For bottom interface, when there is no anchoring system at TRF (as described in item 7.2), present a Table with the envelope of extreme loads and time series of cyclical loads.

### 10.2.3. Riser Wave and Motion Fatigue Analysis Report

This report shall encompass at least the information described below, for girth weld, triple point parent material and transition points (between clad and liner and/or between fatigue sensitive and non fatigue sensitive) along the riser, considering at the cross-section for each of those sixteen (16) points as per section 6:

- a) The description of the adopted approach, either random analysis performed through the time-domain approach (random time-domain dynamic non-linear analysis), and the computer programs used;
- b) Full traceability of the calculations performed;
- c) The set of loading cases used with the discrimination of wave, wind and current characteristics, with the corresponding occurrence, also offsets and FPU motions;
- d) Filenames shall have the same root names of the fatigue loading cases table, in order to facilitate the record tracking procedure;
- e) The wave spectrum discretization adopted;
- f) The FXJ stiffness used for each simulated loading case;
- g) The stresses concentration factors (SCFs) and any other factor adopted for girth weld joints and their calculation procedure;
- h) Tabulated results of the worst unfactored fatigue life case for each critical region of all risers, coming from the combination of all loading cases of long-term, for each internal fluid density considered as a base case. The loading case that produces the highest fatigue damage, and the critical point around the riser section with this highest damage shall be included in this table;
- i) For each critical region of each riser, the ranking of the loading cases of long-term according to the damage contribution regarding the total damage;
- j) Present tabulated unfactored fatigue results of short-term parcel for each return period, for each critical riser regions, for all risers, identifying the loading cases;
- k) Present a totalized unfactored long and short terms fatigue results for each critical riser regions, for all risers, tabulated and graphically, comparing results from different S-N curves for OD and ID wall. Graphical results of the worst lifetime along the riser length shall be generated, with details for some joints at the riser top region, buoyancy modules region (SAG and HOG) and TDZ region;
- l) Comparison of the most critical Von Mises result along the riser length with the yield stress considering the de-rating of the CRA layer, as per item 4.3. Identify for each riser and each internal fluid density the arclength of the most critical von Mises;
- m) The sensitivity analysis results with unfactored fatigue life;
- n) An appendix with all complete unfactored results along the riser length, including base case and sensitivity.

For some results, a model of graphics presentation shall be followed and will be provided by PETROBRAS.

#### 10.2.4. **Riser** VIV Fatigue Analysis Report

This report shall encompass information's about Current VIV and Heave Induced VIV as described below:

For Current VIV:

- a) Computer program used and loading cases considered;
- b) Full traceability of the calculations performed;



- c) Input files for the computer code used, with mode shapes and curvatures and all input data files related with the VIV analysis in Appendix;
- d) VIV suppressor characteristics and its description of proposed length and positioning along the risers;
- e) Tables and Graphs with all Mode shapes and curvatures that contributes for the riser response, for each critical region of the riser, for all risers;
- f) Table with the complete ranking of the current profiles by order of damage for critical sections;
- g) Table with the most critical current profiles from each short and long terms, identifying the activated mode shapes and its contribution for the total VIV damage;
- h) Tables and graphs of unfactored fatigue life along the riser for the most damage loading case from each short term parcel (10-yr and 100yr) and the total long term parcel separately, and also for the totalized damage from long plus short terms, detailing SAG&HOG and TDZ regions for all risers. All combinations of internal fluid density from base case, pipe wall (ID and OD), riser in-plane and out-of-plane vibrations shall be presented separately along the entire riser length. Identify the arclength of the most critical sections for fatigue life. Appendix shall present in detail all the results of each current profile of each riser;
- i) Graphs of maximum RMS of A/D x arclength of the riser and maximum RMS of Stresses x arclength of the riser, associated to the critical current profiles of each critical region of riser that provides higher damages;
- j) DAFs calculated per current profile for all rigid risers, flexible risers and umbilicals in Appendix. The proposed DAF to be adopted in riser interference analysis shall be clearly justified in the document **Riser Design Premises and Methodology Report**;
- k) The sensitivity analysis results and their consequences for the Design life of the riser;
- l) An appendix with all complete unfactored results along the riser length, including base case and sensitivity.

For Heave Induced VIV:

- a) All data used, procedures and final results;
- b) Full traceability of the calculations performed;
- c) All equivalent current profiles adopted in analysis shall be provided in Appendix, but the identification of the most damaging events shall be reported in the main text body;
- d) Tables and graphs of unfactored fatigue life along the riser for the most damage loading cases from each short and long term parcels, separately and totalized, detailing SAG&HOG and TDZ regions, for each internal fluid density from base case in ID and OD wall. The arclength of the most critical fatigue life for each critical region shall be identified in tables for out-of-plane vibration. For all other loading cases, present the same results in Appendix;
- e) An appendix with all complete unfactored results along the riser length.

For some results, a model of graphics presentation shall be followed and will be provided by PETROBRAS.

#### 10.2.5. **Riser** Slugging Analysis Report

This report shall provide:



- a) Computer program used and loading cases considered;
- b) Full traceability of the calculations performed;
- c) The full riser analysis model, also providing the load cases applied, soil bathymetry adopted and any mesh interpolation related to the provided fluid data;
- d) The description of the procedure and the results obtained;
- e) The calculation of the percentual of occurrence for each load case;
- f) Results from static and/or dynamic analyses;
- g) Tables with fatigue life results for all load cases;
- h) The graphical distribution of fatigue life along the risers studied due to slugging;
- i) Stress Histograms of critical joints for all load cases;
- j) Envelope of maximum stresses along the riser caused by slugging;
- k) The sensitivity analysis results and their consequences for the Design life of the riser;
- l) An appendix with all complete unfactored results along the riser length, including base case and sensitivity.

For some results, a model of graphics presentation shall be followed and will be provided by PETROBRAS.

#### 10.2.6. Riser Combined Fatigue Analysis Summary Report

This report shall encompass the information described below, considering the contribution of all sources of the fatigue damage factored by their respective DFF, including Installation, and also present the damage totalization along the riser length (as required in section 6):

- a) General description of riser configuration and the position of buoyance modules and strakes along the line. The definition of length and locations of the critical riser sections, considering all sources of fatigue damage (Wave and Motion, VIM, current VIV, heave induced VIV, Slugging effect, Installation, when applicable);
- b) Full traceability of the calculations performed;
- c) An appendix with original tables of UNFACTORED fatigue life already combining short-term and long-term shall also be presented separately for each fatigue parcel: Wave and Motion, VIM (if applicable), VIV, HVIV and Slugging (if applicable). Base case and sensitivities shall be presented in separate files;
- d) An appendix with tables and Graphs of complete combined FACTORED fatigue life results for each riser, for ID and OD, comparing linear and quadratic summation, including installation parcel. An Excel spreadsheet file shall present all calculations performed for damage combination. Base case and sensitivities shall be presented in separate files;
- e) The combination of damage shall consider the most critical condition from each parcel (example for VIV, the worst between in-plane and out-of-plane vibration along the entire riser), separately for internal wall and external wall;
- f) For fatigue sensitivities, these considerations shall be followed:



TECHNICAL SPECIFICATION

Nº: I-ET-0000.00-0000-274-P9U-001

REV. H

GENERAL

SHEET: 59 de 72

TITLE:

SLWR DETAILED STRUCTURAL DESIGN  
REQUIREMENTS

EDR

-

- i. Fatigue parcels that have a correspondent sensitivity case, combination shall be performed between them, even if the fluid densities are different. In case of over conservatism, the same fluid contents may be analyzed;
- ii. Whenever a fatigue parcel does not have a correspondent sensitivity case, base case shall be used for the totalization of the missing parcel.
- g) The percentual contribution of each parcel of fatigue to the total damage, at least for one critical and one non critical riser of each riser function;
- h) An appendix with stress histograms of most critical riser per function, with contribution of all fatigue damage parcels and each one separately, for ECA study: Wave and Motion, VIM (if applicable), Current VIV, HVIV and Slugging (if applicable), covering all risers from the same function and critical joints as per described in (k) from item 6;
- i) Graphical results shall be generated for the critical riser per function and for all riser critical regions, presenting the comparison between histograms of number of stress cycles and histograms of the damage for each S-N curve analyzed.

For some results, a model of graphics presentation shall be followed and will be provided by PETROBRAS.

#### 10.2.7. Riser Efforts at Monitoring System Report

This report shall encompass the information about the riser efforts located at the monitoring system point, as mentioned in section 4.1, for all monitored risers, according to technical specification [35] or other contractual document referring riser monitoring system in [1] and [2].

This envelope of effort by load category will be adopted to set some level of alarms in FPU during riser's operating.

<b>TECHNICAL SPECIFICATION</b>	Nº: <b>I-ET-0000.00-0000-274-P9U-001</b>	REV. <b>H</b>
<b>GENERAL</b>		SHEET: 60 de 72
TITLE: <b>SLWR DETAILED STRUCTURAL DESIGN REQUIREMENTS</b>		EDR
		-

## 11. REFERENCES

- [1] Project “Detailed Engineering, Procurement, Construction and Installation of Rigid Pipeline” <sup>(1)</sup>
- [2] Project “Design Basis for Engineering, Procurement, Construction and Installation of Rigid Pipelines” <sup>(1)</sup>
- [3] DNV-ST-F201 – “Dynamic Risers”– Det Norske Veritas (Latest Edition)
- [4] DNV-ST-F101 – “Submarine Pipeline Systems”– Det Norske Veritas (Latest Edition)
- [5] DNV-RP-C203 – “Fatigue Design of Offshore Steel Structures”, (Latest Edition).
- [6] DNV-RP-F204 – “Riser Fatigue”, (Latest Edition)
- [7] DNV-RP-C205 – “Environmental Conditions and Environmental Loads”, (Latest Edition)
- [8] DNV Guideline for Design and Construction of Lined and Clad Pipelines - JIP Lined and Clad Pipelines Materials, Phase 4 – Revision 1 – 07/06/2018
- [9] I-ET-0000.00-0000-219-P9U-001 – Mechanically Lined Pipe (MLP) Requirements – (Latest Revision)
- [10] I-ET-0000.00-0000-219-P9U-002 – CRA Clad Pipe Requirements – (Latest Revision)
- [11] I-ET-0000.00-0000-211-P9U-001 – SAWL Pipes Requirements – (Latest Revision)
- [12] I-ET-0000.00-0000-211-P9U-002 – Seamless (SMLS) Pipes Requirements – (Latest Revision)
- [13] I-ET-3010.00-1500-274-P56-001 – Riser Interference Analysis **Report** – (Latest Revision)
- [14] I-ET-0000.00-0000-966-P9U-001 – **Riser** Installation Analyses **Report** - (Latest Revision)
- [15] I-ET-0000.00-0000-940-PIP-002 - Riser-Soil Interaction Analysis **– (Latest Revision)**
- [16] Project Metocean Data <sup>(1)</sup>
- [17] Project Duration of extreme current profiles and Clusters of simultaneous metocean conditions <sup>(1)</sup>
- [18] Project operational metocean data for planning of operations <sup>(1)</sup>
- [19] I-ET-0000.00-0000-290-P9U-003 – Flexible Joint Specification – (Latest Revision)
- [20] I-ET-0000.00-0000-290-P9U-004 – Titanium Stress Joint Specification – (Latest Revision)
- [21] I-ET-0000.00-0000-290-P9U-005 – Titanium Pull-in Tube Specification – (Latest Revision)
- [22] I-ET-0000.00-0000-290-P9U-006 – Hang-off Adaptor Specification – (Latest Revision)
- [23] I-ET-0000.00-0000-940-P9U-002 – Rigid Pipeline On-bottom Roughness and Free Span Design – (Latest revision)
- [24] I-ET-0000.00-0000-940-P9U-004 – On-bottom Stability Analysis – (Latest revision)
- [25] DNV Guideline for Installation of rigid and flexible pipelines, umbilicals and subsea power cables – analyses, Revision 3 – 18/12/2015
- [26] Project Material Requirements <sup>(1)</sup>

**TECHNICAL SPECIFICATION**Nº: **I-ET-0000.00-0000-274-P9U-001**REV. **H**

GENERAL

SHEET: 61 de 72

TITLE:

**SLWR DETAILED STRUCTURAL DESIGN  
REQUIREMENTS**

EDR

-

- [27] Research Article: Experimental and Numerical Study of Fatigue Damage Assessment under Combined High and Low Cycle Loading, Chaoshuai Han, Xianqiang Qu, Yongliang Ma and Dexin Shi, <https://doi.org/10.1155/2018/9045658>
- [28] OMAE2010-20119 – Methodology for time domain fatigue life assessment of risers and umbilicals
- [29] I-ET-0000.00-0000-974-P9U-001 - Hydrostatic Test of Subsea Pipelines and Risers – (Latest Revision)
- [30] Project "Caracterização dos Fluidos Deslocados"<sup>(1)</sup>
- [31] Project "Interface Data for Subsea System EPCI"<sup>(1)</sup>
- [32] I-ET-0000.00-0000-966-P9U-002 - PRE-LAY, WET STORAGE AND RECOVERY – (Latest Revision).
- [33] I-ET-0000.00-0000-278-P9U-001 – Technical Specification for Vortex Induced Vibration Suppressors – (Latest Revision)
- [34] I-ET-0000.00-0000-250-P9U-002 – Minimum Requirements for Buoyancy Modules for Flowlines and Risers – (Latest Revision)
- [35] I-ET-3000.00-5529-850-PX9-001 – Rigid Riser Monitoring System (RRMS) – Riser Contractor Scope – (Latest Revision)

<sup>(1)</sup> Project reference number to be informed within a Project Document List, to be released during BID phase.

## APPENDIX A FXJ STIFFNESS AS A FUNCTION OF THE ALTERNATING ANGLE

The FXJ bending stiffness curve provided by the supplier presents the **dynamic bending stiffness** as a function of the **angular variation** values, which are highly dependent on the type of the applied loads:

- Constant bending stiffness is assumed for static rotations;
- Variable bending stiffness for dynamic loads, depending on the amplitude of the alternating angle.

When the dynamic stiffness are divided by the static stiffness value, it can be obtained a **stiffening factor**, which is different for each dynamic loading case. This factor can be assumed as constant along the dynamic analysis.

Initially is assumed the stiffest value of the supplier curve (in general corresponding to 0.01 deg of alternating angle) for all loading cases, in order to obtain the level of the alternating angle for each loading case. In a second analysis cycle, new dynamic stiffness is used for each case.

The angular variation ( $\alpha$ ) occurs around a mean deflection ( $\theta_m$ ), as presented in Figure 11.

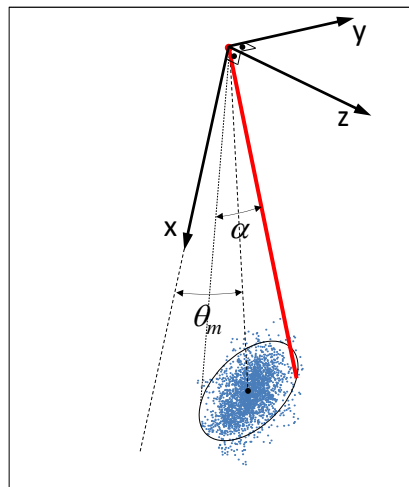

Figure 11 – Eccentric angular variation

The calculation of the curve of total angular variation can be done based on the curves of angular variation on X-Y and X-Z planes. The proposed procedure preserves the signal of the relative angle, by projecting the riser in each one of the planes as presented in Figure 12.

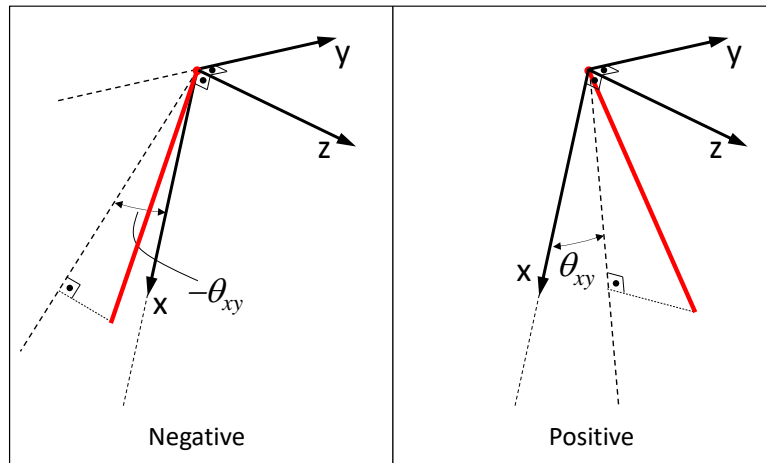

Figure 12 – Angular variation in X-Y plane

Figure 13 shows an example of angular variation curves on each plane.

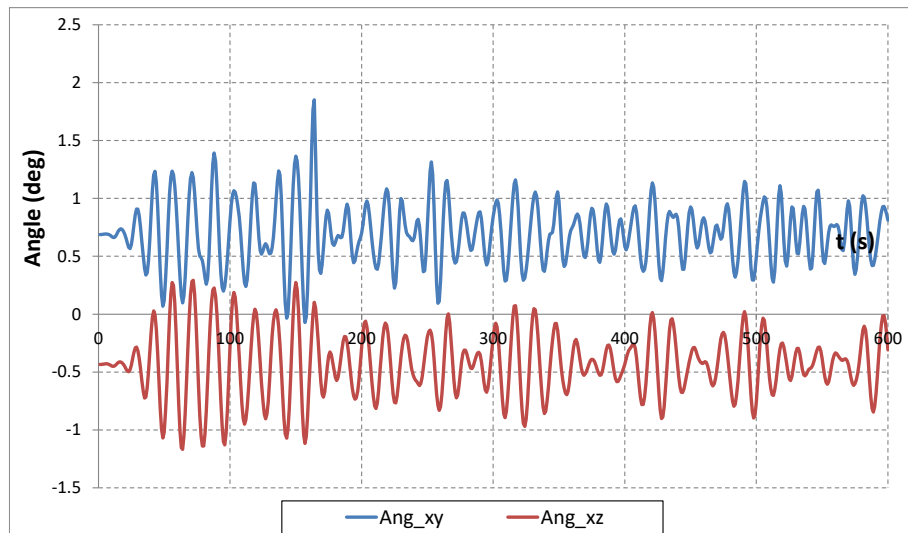

Figure 13 – Angular variation curves on X-Y and X-Z planes

The value employed to determine the FXJ dynamic stiffness is obtained by the variation around the mean position, as presented in Figure 14.

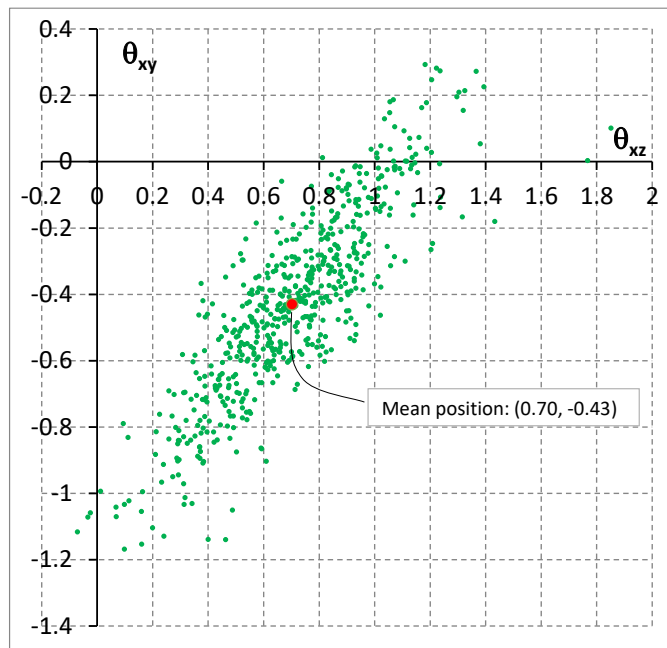

Figure 14 – Rotation vector path on Y-Z plane.

Figure 11 present only the variation, removing the mean value. Besides, this variation can be calculated in any direction, i.e., any plane that comprises the x-axis of the fixed FXJ support reference system. Two different approaches to determine these directions are presented below:

- **Main Direction:** linear adjustment for the points that represent the angular variation;
- **Maximum Amplitude Direction:** direction that provide the maximum amplitude of angular variation

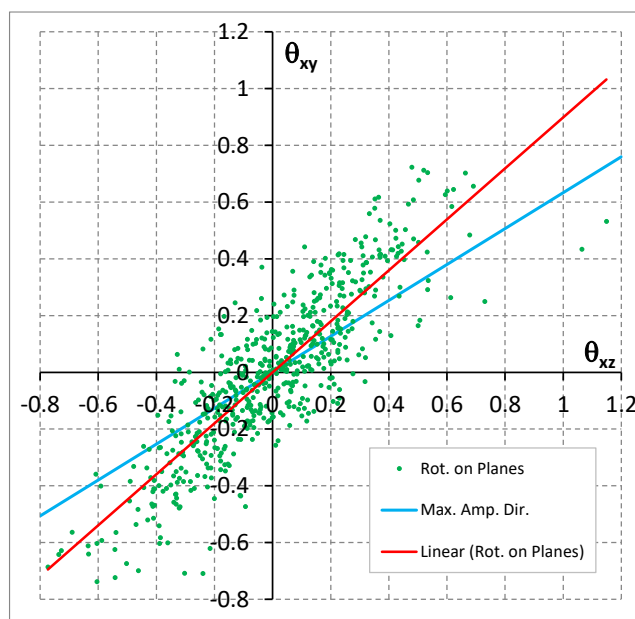

Figure 15 – Directions for angular variation calculation.



TECHNICAL SPECIFICATION	Nº: I-ET-0000.00-0000-274-P9U-001	REV. H
GENERAL		SHEET: 65 de 72
TITLE: SLWR DETAILED STRUCTURAL DESIGN REQUIREMENTS		EDR
		-

The best approach will depend on the applicability of the analysis. If the most conservative for the analysis is to use a low stiffness, it is recommended to use Maximum Amplitude Curve. On the other hand, if the most conservative is a high stiffness, it is recommended to use the Main Direction Curve.

Care shall be taken to determine direction for angular variation when second order roll motions are applied together with first order motions, since a lateral deviation can occur and difficult the automatization on selection of main angular direction.

After determining the direction, the angular variation curve is calculated projecting each point in this direction. Figure 16 presents, as an example, the curves obtained by the point of Figure 11.

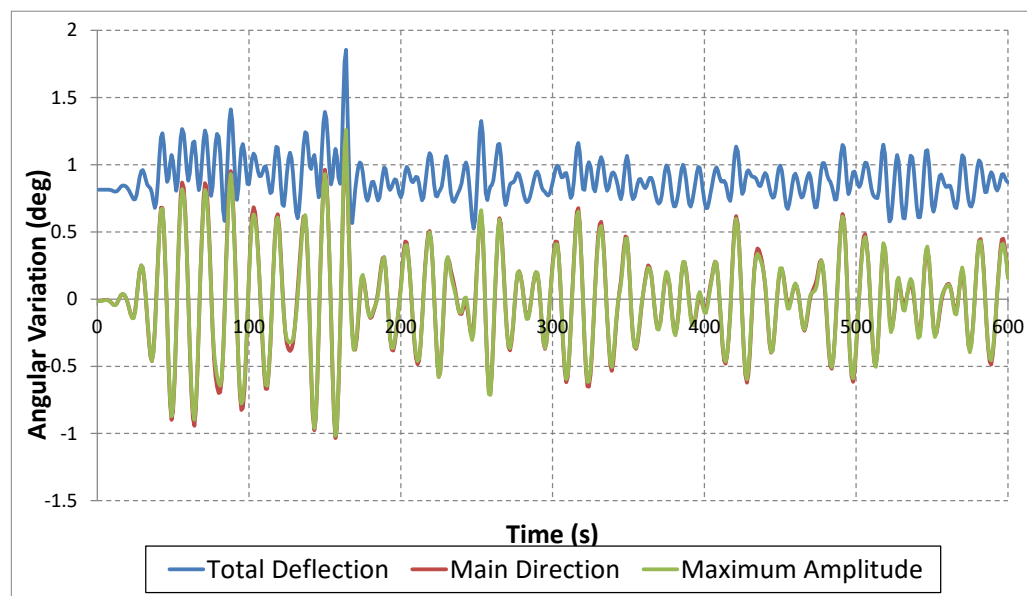

Figure 16 – Angular variation curves

The **standard deviation of the angular variation** curve can be considered as a representative FXJ angular variation, which will correspond to the appropriate stiffness on the supplier curve, for each loading case.

The angular variation representative value depends on the complete signal of the riser top relative rotations. For this reason, to use a FXJ stiffness varying along the dynamic analysis, CONTRACTOR shall guarantee that the rotation history is considered up to each time step, using the procedure described above.

## APPENDIX B RISER BOTTOM CURRENT PROFILE INTERPOLATION CRITERIA

In case current profiles (extreme and fatigue) do not concur with the WD from the design, an interpolation shall be adopted to adjust the current profiles near bottom, in accordance with the criteria in the example presented below.

- WDref (reference water depth of the design) = 1980 m.

Considering that this value is located between 1800 m and 2015 m from original Metocean profile.

Current intensity shall be calculated in two steps:

From 1800 m to (WDref - 10 m): (1800 to 1970): current velocity shall be interpolated linearly between 1800 m and 2015 m.

From (WDref - 10 m) to 0 m: (1970 to 1980): a linear decay on the current velocity shall be considered up to zero.

Current direction shall be adopted as the direction of the WD nearest to the necessary WD.

For WD higher than WDref, the values will be neglected.

Example:

Table 11  
Interpolation example for bottom current profile

WD (m)	Velocity (m/s)	Direction
0	0.60 (*1)	NNE (*1)
50	0.60	NNE
100	0.60	NNE
150	0.54	NNE
200	0.49	NNE
250	0.43	NNE
300	0.39	NNE
350	0.36	NNE
800	0.22	NNE
1200	0.20	NNE
1600	0.18	NE
1800	0.17	NE
1970	0.16	NE
1980	0.00	ENE
2150	0.15	ENE
2200	0.09	E

(\*1) For surface (0 m), the values of velocity and direction will be filled in this way:

- For extreme current profiles, when surface (0 m) are not provided by Metocean document, repeated from 50 m values; when surface (0 m) are presented by Metocean, use them.



TECHNICAL SPECIFICATION

Nº: I-ET-0000.00-0000-274-P9U-001

REV. H

GENERAL

SHEET: 67 de 72

TITLE:

SLWR DETAILED STRUCTURAL DESIGN  
REQUIREMENTS

EDR

-

- For fatigue current profiles, use the values as indicated in document with the clusterization for surface (0m), with the associated surface fatigue current profile from Metocean.
- For 98% non exceedance current profile, when surface (0 m) are not provided by Metocean document, repeated from 50 m values; when surface (0 m) are presented by Metocean, use them.

Velocity for 1970 m level:

- $Velocity = 0.17 + (0.15-0.17) \cdot (1970-1800) / (2150-1800) = 0.17 - 0.02 \cdot (170/350) = 0.16$
- Direction for 1970 m level: 2150-1970 = 180 m; 1970-1800 = 170 m; Direction = NE

### APPENDIX C UPSET-END STRESSES

As an initial hypothesis, a simple way to consider the influence of the upset would be to apply a stress reduction factor (*SRF*), due to the increase in thickness, in the stresses calculated with the pipe without thickening. Assuming that the upset-ends is applied where the bending stresses are dominant, this factor can be determined by the relationship between the bending stresses in the tube with and without the thickening, as described below.

Writing the bending stresses, as a function of the pipe diameters, we have:

$$\sigma = \frac{My}{I} = \frac{32M}{\pi} \frac{D}{(D_e^4 - D_i^4)} \quad (1)$$

Where:

- *M* is the applied bending moment on the cross section;
- *D* is the diameter referring to the point where the stress is to be calculated (external or internal wall);
- *D<sub>e</sub>* is the outer diameter of the tube;
- *D<sub>i</sub>* is the inner diameter of the tube.

The bending moment (*M*), for a given bending deformation (rotation), depends on the global stiffness of the pipe, which can be influenced by the presence of the upset-end. Thus, for pipes without upset-end, the bending moment can be written as:

$$M_p = \frac{\theta EI}{L} = \frac{\pi \theta E (D_p^4 - D_i^4)}{64L} \quad (2)$$

Where:

- *E* is the Young modulus of the pipe material;
- *D<sub>p</sub>* is the outer diameter of the pipe without an upset-end;
- *θ* is the relative rotation between two sections of the tube, apart from each other by the length *L* (length of the joint).

Substituting (2) in (1), for the external pipe wall and simplifying the expressions, we have:

$$\sigma_p = \frac{\theta E D_p}{2L} \quad (3)$$

In pipes with the upset-ends, the bending moment can be written as:

$$M_u = \frac{\theta E}{\frac{L_u}{I_u} + \frac{L_p}{I_p}} = \frac{\pi \theta E}{64 \left( \frac{L_u}{(D_u^4 - D_i^4)} + \frac{L_p}{(D_p^4 - D_i^4)} \right)} \quad (4)$$

Where:

- $L_u$  is the upset-end length;
- $L_p$  is the pipe length without the upset-end.

In a pipe joint of length  $L$ , with an upset-end of length  $L_u$  at each end, Eq. (4) may be rewritten as follows:

$$M_u = \frac{\pi \theta E}{64 \left( \frac{2L_u}{(D_u^4 - D_i^4)} + \frac{L - 2L_u}{(D_p^4 - D_i^4)} \right)} \quad (5)$$

Substituting (5) in (1), for the external pipe wall and simplifying the expressions, we have:

$$\sigma_u = \frac{\theta E D_u}{2 \left( 2L_u + \frac{(L - 2L_u)(D_u^4 - D_i^4)}{(D_p^4 - D_i^4)} \right)} \quad (6)$$

Assuming that the upset-end does not influence in the global displacements of the riser, i.e. the cross section rotations are the same for pipes with and without the upset-end, the stress reduction factor on the outer pipe wall with upset-end, can be obtained as follows:

$$SRF_e = \frac{\sigma_u}{\sigma_p} = \frac{D_u}{D_p} \left( \frac{L(D_p^4 - D_i^4)}{2L_u(D_p^4 - D_i^4) + (L - 2L_u)(D_u^4 - D_i^4)} \right) \quad (7)$$

For the inner wall, the expression takes the following form:

$$SRF_i = \frac{L(D_p^4 - D_i^4)}{2L_u(D_p^4 - D_i^4) + (L - 2L_u)(D_u^4 - D_i^4)} \quad (8)$$

The expressions presented here are simplifications and may overestimate the stress reduction. In order to avoid this problem, it is recommended to apply a safety factor ( $SF$ ) over the stress reduction factor. Thus, Eqs. (8) and (7) can be rewritten as follows, respectively:

$$SRF_i = SF \frac{L(D_p^4 - D_i^4)}{2L_u(D_p^4 - D_i^4) + (L - 2L_u)(D_u^4 - D_i^4)} \quad (9)$$

$$SRF_e = \frac{D_u}{D_p} SRF_i \quad (10)$$

It is recommended to use a safety factor of at least 5% ( $SF = 1.05$ ).

## APPENDIX D VIV TDP SPREADING

Current VIV analyses are normally carried out with the riser at the mean static configuration by using a linearized frequency domain approach, which leads to a concentrated damage at the Touchdown Point (TDP). This appendix shows a simplified methodology to spread the VIV damage at Touchdown Zone (TDZ) due to the movements of the TDP in operational conditions.

The methodology presented here in is based on the following assumptions:

- VIV analysis is performed with the riser in the mean static configuration;
- It is assumed that the damage of VIV in the TDP is independent of the displacement of the floating unit, varying only its position along the riser;
- The distribution of the TDP positions can be obtained from wave fatigue analysis, where offsets and/or low-frequency movements are considered.

As a background, let's assume the hypothetical example of a SCR:

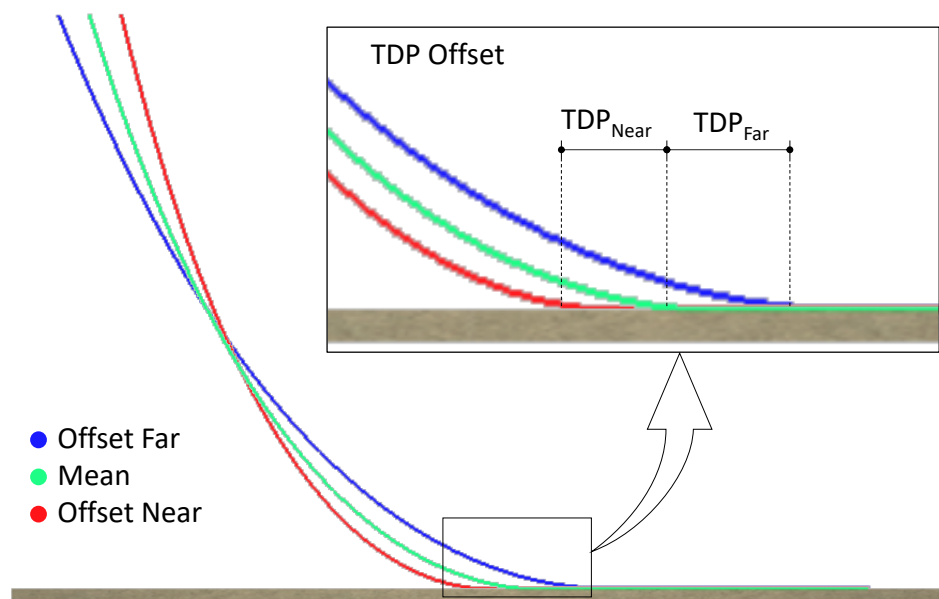

Figure 17 – TDP offset

Due to the floating unit movements, the TDP position along line changes, as shown in Figure 17. Taking as reference the mean TDP position, it is possible to calculate the TDP offset, which is the movement of TDP along the line length.

A good approximation of the distribution of TDP positions may be obtained from the whole set of Wave and Motion Fatigue analysis. As an example, let's consider the TDP displacements along line for a set of five wave fatigue load cases, as show in Table 12.

Table 12  
Wave Fatigue Seastates for Storm Conditions

Case	Occurrence	TDP Offset
LC1	0.15	-5.00
LC2	0.20	-2.00
LC3	0.30	0.00
LC4	0.20	2.00
LC5	0.15	5.00

Let's also consider the results of a VIV analysis at the TDP region, as shown in Figure 18.

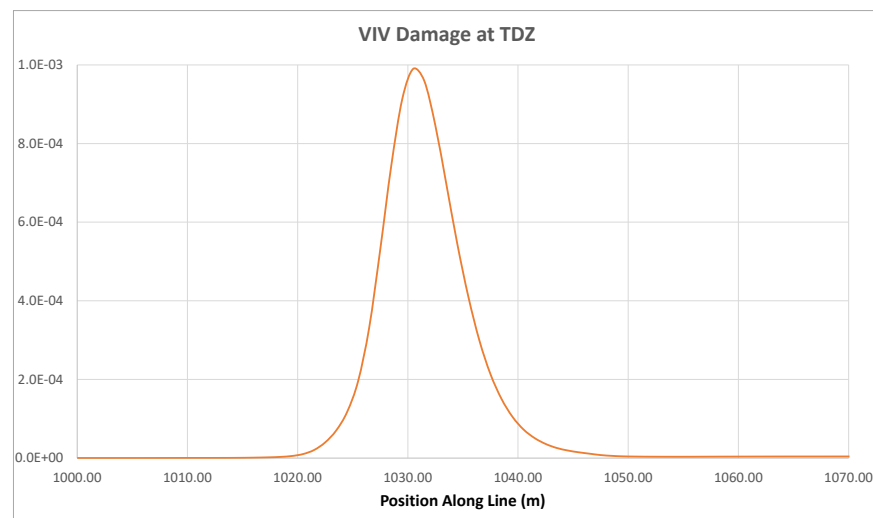

Figure 18 – VIV damage at TDP

The damage shown in Figure 18 can be spread around the TDZ (TDP Offsets) presented in Table 12, by using Eq. 1:

$$\sigma D_S = \sum D_{SH}^i O^i \quad (11)$$

Where:  $D_S$ : Spread damage

$D_{SH}^i$ : Displaced damage for loading case  $i$  (original damage displaced along line by TDP offset)

$O^i$ : Percentage of occurrence for loading case  $i$ .

The result of this procedure is shown in Figure 19:

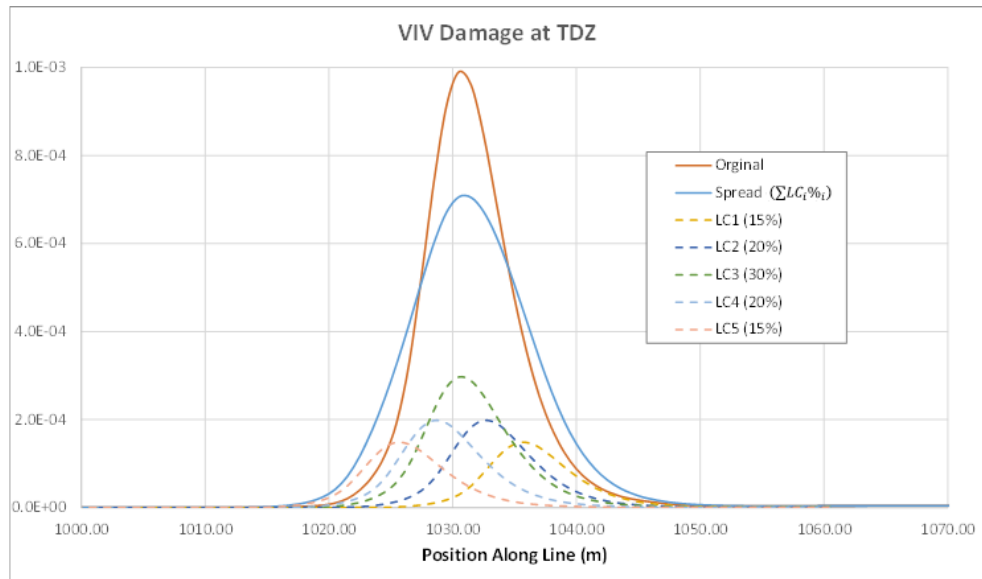

Figure 19 – VIV damage spreading at TDP

**Note:** The VIV damage spreading shall be applied only at the TDP region.

See the attached spreadsheet file “VIVDamageSpreading” as example.