	TECHNICAL SPECIFICATION		Nº: I-ET-XXXX.XX-5510-760-PPT-579						
	CLIENT: SRGE		SHEET: 1 of 36						
	PROGRAM: CHARTERED UNITS								
	AREA: SRGE / ESUP / PIES		-						
TIC	TITLE: TELECOM MASTER SPECIFICATIONS FOR FPSO CHARTERED								
INDEX OF REVISIONS									
REV.	DESCRIPTION AND/OR REVISED SHEETS								
0	ORIGINAL								
A	Items revised: 12.14.1; 18.2.1; 26; 28.11.3; 28.1.2; 31.1.1								
B	GENERAL REVISION								
(ITEMS MARKED IN YELLOW SHALL BE EVOLUTED FOR EACH PROJECT)									
	REV. 0	REV. A	REV. B	REV. C	REV. D	REV. E	REV. F	REV. G	REV. H
DATE	28/07/2020	22/03/2022	30/05/2022						
DESIGN	AUTPROJ-US	PROJ-US	PROJ-US						
EXECUTION	ROBSON	ROBSON	ROBSON						
CHECK	CHRISTIANO	CHRISTIANO	CHRISTIANO						
APPROVAL	DIOGO	JOMAR	JOMAR						
THE DATA, OR PARTS THEREOF, ARE PETROBRAS PROPERTY AND SHALL NOT BE USED IN ANY WAY WITHOUT THEIR PERMISSION.									
THIS FORM IS IN ACCORDANCE WITH PETROBRAS STANDARD N-381 – REV. F									



TITLE:

TELECOM MASTER SPECIFICATIONS FOR FPSO CHARTERED

I N D E X

1.	OBJECTIVE	3
2.	REFERENCE	3
3.	TERMS, ABBREVIATIONS AND DEFINITIONS.....	3
4.	GMDSS SYSTEM	4
5.	OPERATIONAL RADIO SYSTEM.....	4
6.	EPTA CLASS M.....	5
7.	ACTIVE REPEATER SYSTEM	8
8.	PUBLIC ADDRESS AND GENERAL ALARM SYSTEM	10
9.	TVRO SYSTEM	11
10.	UHF TV SYSTEM	11
11.	CONTRACTOR TELEPHONE SYSTEM.....	11
12.	PETROBRAS STRUCTURED VOICE AND DATA NETWORKS.....	12
13.	PETROBRAS TELEPHONE SYSTEM	17
14.	INMARSAT	17
15.	PETROBRAS WIRELESS LAN – WLAN	17
16.	PETROBRAS TELECOMMUNICATION ROOM	18
17.	CLOSED RACKS FOR VOICE AND DATA NETWORK	18
18.	PETROBRAS VIDEOCONFERENCE SYSTEM.....	20
19.	INTEGRATED PETROBRAS AND CONTRACTOR VSAT SOLUTION.....	23
20.	LAST MILE CIRCUITS REQUIREMENTS	23
21.	EQUIPMENTS SUPPLIED BY PETROBRAS	27
22.	POWER SYSTEM	27
23.	CONTRACTOR TELECOMMUNICATION SYSTEM	28
24.	DOCUMENTATION	28
25.	INFRASTRUCTURE FOR SUBMARINE FIBER OPTIC NETWORK	29
26.	LTE/4G SYSTEM.....	31
27.	RADIO ROOM.....	32
28.	PRM SYSTEM – TELECOMMUNICATION INFRAESTRUCTURE	32
29.	COMPUTERS AND PRINTERS	33
30.	DMZ FOR THIRD PARTY ACCESS.....	34
31.	CONTRACTOR CCTV SYSTEM	35
32.	CONTRACTOR INDUSTRIAL WIRELESS NETWORK.....	35



TITLE:

TELECOM MASTER SPECIFICATIONS FOR FPSO CHARTERED

1. OBJECTIVE

- 1.1 To present the minimum Telecommunications Systems requirements demanded by PETROBRAS to be supplied and installed in the Unit by CONTRACTOR.

2. REFERENCE

- 2.1 The Telecommunications systems and equipment shall comply with applicable standards specifications and Flag Administration requirements.
- 2.2 CONTRACTOR shall be responsible for obtaining all ANATEL applicable services licenses for operation in Brazil.
- 2.3 Scope of maintenance for equipment used by PETROBRAS.
- 2.3.1. All equipment supplied for PETROBRAS use shall be maintained by CONTRACTOR.
- 2.3.2. PETROBRAS data equipment will be managed remotely by PETROBRAS' NOC. Every maintenance activity shall be informed to PETROBRAS in advance.

3. TERMS, ABBREVIATIONS AND DEFINITIONS

AAFD	Área de Aproximação Final e Decolagem (Final Approach and Takeoff Area)
AC	Alternating Current
AHTS	Anchor Handling Tug Supply
AM	Amplitude Modulation
ANATEL	Agência Nacional de Telecomunicações (Brazilian Telecommunication Authority)
ANSI	American National Standards Institute
EIA	Electronic Industries Alliance
TIA	Telecommunications Industry Association
ART	Anotação De Responsabilidade Técnica (Technical Responsibility Note)
AWG	American Wire Gauge
BUC	Block up Converter
CAB	Cable
CAT	Category
CATV	Community Antenna Television
CCR	Central Control Room
CCTV	Closed Circuit Television
CODEC	Codifier & Decodifier
CREA	Conselho Regional de Arquitetura e Urbanismo (Brazilian Engineering Counsel)
DC	Direct Current
DIO	Dispositivo Intrmediário Óptico (Optical Distribution Drawer)
DSV	Diving Support Vessel
DVD	Digital Versatile Disc
EEX	European Energy Exchange
ENV	Environmental
EPTA	Estação Permissãoária de Tráfego Aéreo (Air Traffic Controller)
ETH	Ethernet
FM	Frequency Modulation
FO	Fiber Optic
GMDSS	Global Maritime Distress Safety System
GPS	Global Positioning System
HDPE	High Density Polyethylene
HDX	High Definition "X" Experience
ICA	Instruções do Comando da Aeronáutica (Aeronautical Brazilian Authority)
IDU	Indoor Data Unit
IMO	International Maritime Organization
IP	Internet Protocol
IS	Intrinsec Safe
ITU	International Telecommunication Union
KVA	Kilo Volt Ampere
LAN	Local Area Network
LED	Light Emitting Diode
LNB	Low Noise Block Converter
LSZH	Low Smoke Zero Halogen
MODU	Mobile Offshore Drilling Unit
MOSCAD	Motorola Supervisory Control And Data Acquisition
NDB	Non Directional Beacon
NOC	Network Operation Center



TITLE:

TELECOM MASTER SPECIFICATIONS FOR FPSO CHARTERED

NTSC	National Television Systems Committee
ODU	Outdoor Data Unit
OMTS	Offloading Monitoring Telemetry System
PAGA	Public Address And General Alarm
PAL-M	Phase Alternate Line Type M
PI	Plant Information
PLL	Phase Locked Loop
PoE	Power Over Ethernet
PP	Patch Panel
PSV	Platform Supply Vessel
ROIP	Radio over IP
SC	Subscription Channel Connector
SFP	Small Form-Factor Pluggable
MM	Multi Mode
SMA	Serviço Móvel Aeronáutico (Aeronautical Mobile Service)
SMM	Serviço Móvel Marítimo (Maritime Mobile Service)
SOLAS	Safety Of Life At Sea
SPL	Sound Pressure Level
TVRO	Television Read Only
UHF	Ultra Highband Frequency
UPS	Uninterruptible Power Supply
UTP	Unshielded Twisted Pair
VAC	Volts Alternating Current
VDC	Volts Direct Current
VMS	Visual Monitoring System
VHF	Very High Frequency
VSAT	Very Small Aperture Terminal
WAN	Wide Area Network

4. GMDSS SYSTEM

- 4.1 Global Maritime Distress and Safety System shall follow all requirements regulated by IMO/SOLAS and Classification Society about International Distress and Safety System.
- 4.2 The Unit shall comply with all the GMDSS requirements for operation in sea area A3, including AIS radio and SSAS equipment.
- 4.3 The AIS equipment shall have one serial port connected to a supplied RS-232 to ethernet converter device manufactured by Advantech MODEL EKI-1522 to be interconnected to PETROBRAS LAN network. The IP address to be configured will be informed by PETROBRAS later.
- 4.4 The GMDSS equipment shall be mounted in a console inside the Radio Room.
- 4.5 It shall comply with at least two maintenance methods required in item 1.6 of HARMONIZATION OF GMDSS REQUIREMENTS FOR RADIO INSTALLATIONS ON BOARD SOLAS SHIPS.

5. OPERATIONAL RADIO SYSTEM

- 5.1 The Radio Communication System shall allow operational communication with supply vessels, other Units and with Brazilian Telecommunication Coastal Station.
- 5.2 A **VHF/FM-SMM Network (Mobile Maritime System)** to allow communication with other platforms and vessels, with the minimum requirements described below:
 - a. 01 (one) non DSC VHF maritime base station in Radio Room (beside the GMDSS console).
 - b. 02 (two) non DSC VHF maritime base stations in Central Control Room (CCR).
 - c. 01 (one) non DSC VHF maritime base station in PETROBRAS' representative office.
 - d. 04 (four) portable VHF maritime portable radios, with display, IS (Intrinsically Safe) remote speaker microphone, spare battery, charger and carry case for each one, configured with all international channels plan for PETROBRAS exclusive use, properly labeled to be distinguished from CONTRACTOR's portable ones.

- e. The radios, batteries and all accessories shall be suitable for operation in zone 1 hazardous areas in an outdoor tropical marine environment.
- f. All radio equipment supplied shall be homologated by ANATEL.
- g. CONTRACTOR shall be responsible for the procedures in order to legalize the system according to Brazilian legislation.

5.3 An **UHF Network (Production and Maintenance Service)** to allow internal communication between utility, process plant or any other area of the Unit, with the minimum requirements described below:

- a. 01 (one) UHF base station in Radio Room.
- b. 02 (two) UHF base stations in Central Control Room.
- c. 08 (eight) portable IS UHF radios with IS external microphone, spare battery and charger for each one, for PETROBRAS exclusive use, properly labeled to be distinguished from CONTRACTOR's portables ones. The radios, batteries and all accessories shall be suitable for operation in zone 1 hazardous areas in an outdoor tropical marine environment.
- d. 04 (four) headphones with cable compatible with the portable UHF radio model.
- e. The minimum operating frequency range of the UHF transceivers shall be from 450 to 470 MHz, with a minimum of 12 (twelve) channels available for programming.
- f. 01 (one) six-way battery charger for portable radios.
- g. The UHF frequency plan will be advised by PETROBRAS during the detailed design.
- h. All radio equipment supplied shall be homologated by ANATEL.
- i. CONTRACTOR shall be responsible for the procedures in order to legalize the system according to Brazilian legislation.
- j. All UHF radios shall use digital modulation technology (DMR) in order to comply with ANATEL Resolution 558/2010.
- k. CONTRACTOR shall supply a programming kit (cables and software) for using in the maintenance and programming of UHF Radios during the unit operation.

5.4 An appropriate operational radio console shall be installed in the Radio Room, beside the GMDSS console. The Radio Communication System shall comprise the following equipment:

- a. VHF/FM-SMM radio (according to item 5.2.a).
- b. UHF radio (according to item 5.3.a).
- c. 02 (two) VHF/AM-SMA radios (according to item 6.1.1).
- d. Public Address Access Panel.
- e. HMS System display (according to item 6.2).

6. EPTA CLASS M

6.1 The EPTA Class M shall enable operational communication among the Unit, helicopters and air navigation aid. It shall be in accordance with the requirements stated in the latest revision of ICA 63-10, ICA 63-25 and NORMAM-27/DPC.

6.2 Radio Equipment

- 6.2.1. It shall be provided 02 (two) VHF/AM-SMA base stations to allow communication between the Unit and helicopters. Both radios shall be installed in the radio communication console in the Radio Room.
 - 6.2.1.1. Both VHF/AM-SMA base stations radios shall have the frequency locked in that one designated by Brazilian Air Force department.
- 6.2.2. It shall be provided 02 (two) hand-portable radio transceivers VHF/AM-SMA for use in the helideck, with appropriate headphone.
- 6.2.3. All the radios equipment supplied shall be homologated by ANATEL.
- 6.2.4. CONTRACTOR shall be responsible for the procedures in order to legalize the EPTA Class M and radios according to Brazilian legislation.
- 6.2.5. According to ICA 63-25/2010, it shall be provided and installed a voice record system for VHF/AM-SMA base station.

6.3 Meteorological and Helideck Monitoring System

- 6.3.1. CONTRACTOR shall provide meteorological and positioning equipment adequate for EPTA (Telecommunications and Air Traffic Station Permission) Class M, according to the requirements stated in ICA 63-10 from the Aeronautical Authority such as:
 - a. Wind speed and direction sensor;
 - b. Relative humidity sensor;
 - c. Barometric pressure sensor;
 - d. Air temperature sensor;
 - e. Pitch, roll and yaw sensors.
- 6.3.2. These sensors outputs shall be automatically generated and displayed in a dedicated monitor in Radio Room.
- 6.3.3. If ENV System already exists in the Unit it will be acceptable to split the sensors signals, however the computer and software installed in the Radio Room shall be independent of the ENV PETROBRAS system.
- 6.3.4. The meteorological and positioning sensors shall be installed in adequate place without obstruction or any another element that could interfere in their reading.
- 6.3.5. Helideck motion monitoring system shall be able to monitor helideck heave, heave velocity, roll, pitch and inclination in real-time.

6.4 Helideck status light

- 6.4.1. It shall be provided a status light at the helideck in order to signaling the helideck status.
- 6.4.2. Helideck status light - An alert visual system aid shall be installed as an aid to warn of conditions that may be dangerous to the helicopter or its occupants.
- 6.4.3. The helideck status light consists of a red light, flashing, installed close to the AAFD limit line, there may be, also, in other locations of the UNIT, so that it is visible in any direction of approach of the aircraft.

6.4.4. The status light when turned on will mean that the helideck does not offer safe conditions for aircraft operation, when the status light is off it means that there is a safe condition to operate on that helideck.

6.4.5. The status light shall be activated by three conditions to be chosen:

- a. Manually by the Radio Operator;
- b. Automatically, when the parameters required in the HMS exceed the limits stipulated by NORMAN-27 or
- c. From the Fire and Gas panel when the platform is in emergency situation.

6.5 INTEGRATED AUDIO AND VIDEO RECORDING SYSTEM

6.5.1. It shall be supplied and installed an integrated audio and video recording system comply with the Brazilian regulations ICA 63-10, ICA 63-25 and NORMAM-27/DPC, following the requirements below:

6.5.2. Audio Recording requirements

6.5.2.1. It shall be provided and installed a voice recorder system, in order to record and store all communications made by the VHF/AM-SMA base station, portable radio VHF/AM-SMA and the Helicopters during the Helideck operation.

6.5.2.2. The audio recorder shall have the following requirements:

- a. Audio recordings shall be automatic during any Aeronautical VHF communications;
- b. Be recorded on a dedicated device onboard;
- c. Recorded audio shall be intelligible;
- d. System shall have redundancy of hard disks to store files;
- e. Recorded audio shall be stored for at least 03 months and be able to be retrieved any time when requested.

6.5.3. Video Recording requirements

6.5.3.1. It shall be installed an exclusive CCTV camera to monitor and record the helideck operations (approach, landing and takeoff).

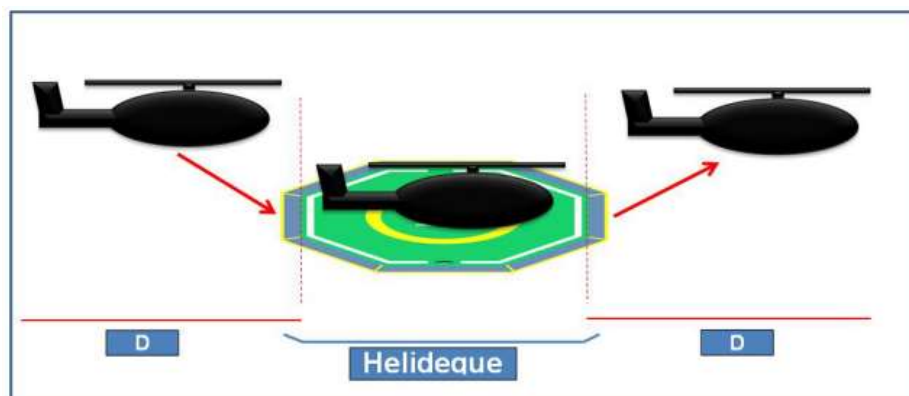

Figure 1: approach, landing and takeoff

- 6.5.3.2. It shall be installed a dedicated display monitor in the Radio Room.
- 6.5.3.3. It shall be provided and installed a video recorder system, integrated with audio system, in order to record and store all images relative to helideck operations.
- 6.5.3.4. This video recorder shall have capacity to store the record registers for 90 (ninety) days at least. All video recording shall be available to be retrieved any time when requested.
- 6.5.3.5. System shall have redundancy of hard disks to store files.

6.5.4. **Audio and Video Recording Recovery Software**

- 6.5.4.1. The recovery software shall have its access protected by login and password, with different level access for each user.
- 6.5.4.2. It shall be able to manually select audio and video passages so that they can be kept stored up to be manually removed.
- 6.5.4.3. Video and voice data shall be stored independently, but the software shall permit simultaneous playback on the same time base.

6.5.5. **Closed rack for Audio and Video Recorder**

- 6.5.5.1. It shall be provided an exclusive closed rack, locked by key, in order to install all the audio e video recorders equipment.

7. **ACTIVE REPEATER SYSTEM**

7.1 The UHF Active network for internal communication shall have a minimum of 05 (five) simultaneous channels. The system shall be composed by active repeater radios and antennas network, including leaked and feeder cables to guarantee communication between all portable radios without any shadow area anywhere in the unit. All these UHF antennas shall be connected to the active repeater cabinet coupler.

7.2 The following drawing exemplifies the Active Repeater System arrangement.

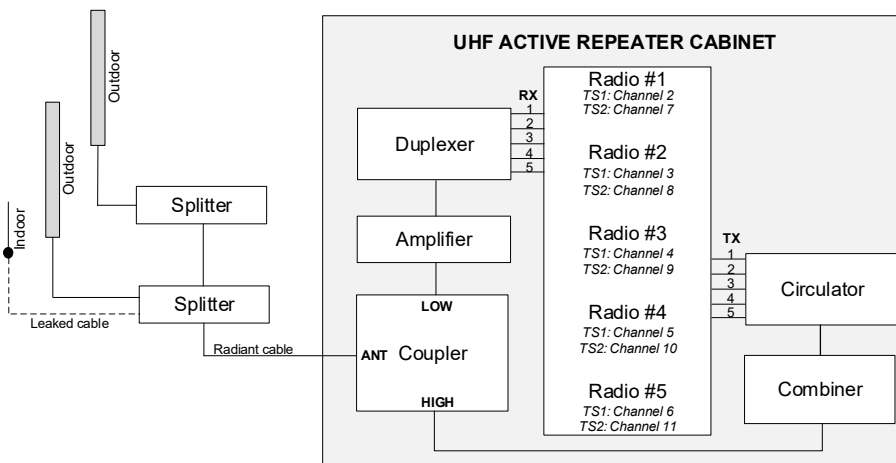

Figure 2: typical UHF active repeater system

7.3 The active repeater equipment shall be housed in 19 inches closed rack. The cable network shall be connected to the rack through combiners and circulators.



TITLE:

TELECOM MASTER SPECIFICATIONS FOR FPSO CHARTERED

- 7.4 The Active Repeater system shall be powered by the AC essential bus bar. Under a failure condition of the main AC power supply, the system shall be kept working through a dedicated VDC power system with 30 (thirty) minutes minimum autonomy.
- 7.5 CONTRACTOR shall send the proposed solution for the Active Repeater System to PETROBRAS approval during detailed design.
- 7.6 Calculation report regarding to all indoor and outdoor areas shall be developed and sent for PETROBRAS approval.
- 7.7 Equipment shall be homologated by ANATEL.
- 7.8 CONTRACTOR shall be responsible for the procedures in order to legalize the system according to Brazilian legislation.
- 7.9 All UHF repeaters shall use the digital modulation technology in order to comply with ANATEL Resolution 558/2010.
- 7.10 The frequency plan channels will be informed and defined by PETROBRAS later and it will be composed by 05 (five) frequencies pairs, a color code index and 100 (a hundred) sequential ID numbers.
- 7.11 CONTRACTOR shall use the PETROBRAS channels from channel 02 up to channel 06 to support the operation and maintenance activities.
- 7.12 CONTRACTOR can use 02 (two) additional UHF active repeater radios for configure 04 channels for its exclusive use by means of the voice slot facility in the portable radios. For that, it shall be used the same frequency plan provided by the PETROBRAS.
- 7.13 Follow the 05 (five) main channels functions proposal:
 - a. Channel 02 – Safety and emergency coordination.
 - b. Channel 03 – Operation
 - c. Channel 04 – Operation
 - d. Channel 05 – Maintenance
 - e. Channel 06 – Maintenance
- 7.13.1. In case of 03 (three) repeater radios to the used, it will be possible to have a channel 07, which is suggested to be used for Embarkation purposes.
- 7.14 Every frequency pair used shall be configured on dedicated channel to work point-to-point (simplex mode) in case of active repeater radio fails.
- 7.15 Following the proposal table for the UHF active repeater and UHF portable radios configuration.

UHF Active Repeater frequencies	Active repeater 01				Active repeater 02				Active repeater 03				
	Freq TX		Freq RX		Freq TX		Freq RX		Freq TX		Freq RX		
	469,xxxx MHz		459,xxxx MHz		469,xxxx MHz		459,xxxx MHz		469,xxxx MHz		459,xxxx MHz		
Voice slot 1		Voice slot 2		Voice slot 1		Voice slot 2		Voice slot 1		Voice slot 2			
Channel 02 SAFETY		Channel 03 OPERATION		Channel 04 OPERATION		Channel 05 MAINTENANCE		Channel 06 MAINTENANCE		Channel 07 EMBARKATION			
UHF Base stations and Portable radios with Active Repeater		Freq TX	Freq RX	Freq TX	Freq RX	Freq TX	Freq RX	Freq TX	Freq RX	Freq TX	Freq RX	Freq TX	Freq RX
		459,xxxx	469,xxxx	459,xxxx	469,xxxx	459,xxxx	469,xxxx	459,xxxx	469,xxxx	459,xxxx	469,xxxx	459,xxxx	469,xxxx

UHF Active Repeater frequencies	Active repeater 04				Active repeater 05				
	Freq TX		Freq RX		Freq TX		Freq RX		
	469,xxxx MHz		459,xxxx MHz		469,xxxx MHz		459,xxxx MHz		
Voice slot 1		Voice slot 2		Voice slot 1		Voice slot 2			
Channel 08 CONTRACTOR		Channel 09 CONTRACTOR		Channel 10 CONTRACTOR		Channel 11 CONTRACTOR			
UHF Base stations and Portable radios with Active Repeater		Freq TX	Freq RX	Freq TX	Freq RX	Freq TX	Freq RX	Freq TX	Freq RX
		459,xxxx	469,xxxx	459,xxxx	469,xxxx	459,xxxx	469,xxxx	459,xxxx	469,xxxx

Table 1: UHF frequency and channel plan

TITLE:

TELECOM MASTER SPECIFICATIONS FOR FPSO CHARTERED

- 7.16 The High frequencies (469,xxx MHz) shall be configured in the (TX) of active repeaters.
- 7.17 The Low frequencies (459,xxx MHz) shall be configured in the (TX) of portable and base station radios.
- 7.18 CONTRACTOR shall guarantee the power level -85 dBm (or better) anywhere on the unit.

8. PUBLIC ADDRESS AND GENERAL ALARM SYSTEM

- 8.1 The public address and general alarm system (PAGA system) shall enable voice communication, operational announcements, priority announcements and safety warnings.
- 8.2 This system shall be dimensioned for broadcasting of sound signals in the whole Unit with a call line, alarm line and priority messages. In areas where the environment noise exceeds 90 dBA (according to NR-37), signaling lamps shall also be provided in addition to the alarm line.
- 8.3 The unit shall have a fully duplicated PAGA system, consisting of 02 (two) identical systems designated 'A' and 'B', which shall operate as independent units, such that failure of one system does not affect the operation of the other.
- 8.4 The acoustic coverage from the two systems shall be designed to be overlapping and reinforcing.
- 8.5 The "A" and "B" systems shall be installed in separate locations. The cable runs associated with each system ('A' and 'B') shall, where possible, be physically separated. The main PAGA ('A') system shall be installed in the Telecommunication Room and the redundant one ('B') in another room as far as possible from the main one.
- 8.6 The PAGA system shall accept patch calls made through the CONTRACTOR extension lines of the Unit.
- 8.7 The PAGA system shall be powered according to SOLAS/MODU/Classification Society rules.
- 8.8 CONTRACTOR shall submit to PETROBRAS the approval document issued by Classification Society for the PAGA System.

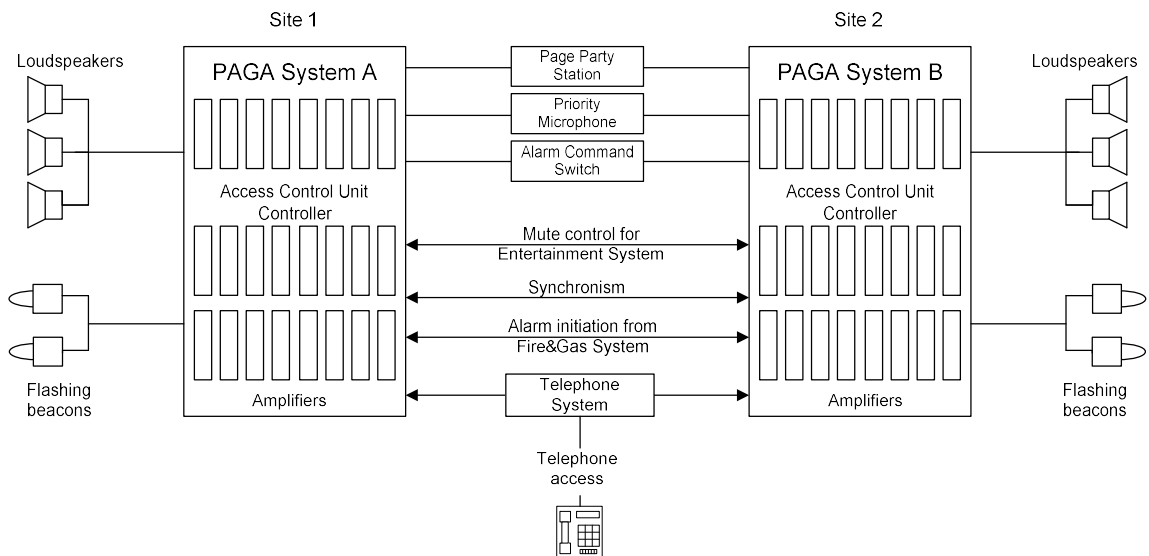

Figure 3: PAGA system general arrangement

9. TVRO SYSTEM

- 9.1 The Unit shall have its own TV system for receiving satellite signals that will be distributed internally by cables throughout the Unit accommodations. This TV system shall have a properly stabilized (auto-tracking) Ku Band antenna system (1.2m diameter) to compensate all movements of the Unit and guarantee the signal level performance without variations.
- 9.2 16 (sixteen) simultaneous pay TV channels shall be provided by CONTRACTOR, using a Brazilian PAYTV operator. The TV channels will be advised by PETROBRAS.
- 9.3 It shall be provided internal cabling network for distribution of CATV in all PETROBRAS cabins, offices, videoconference room and meeting room.
- 9.4 The TV outlets shall be provided with female F-type connectors.
- 9.5 It shall be installed a TVRO closed rack with 19 inches for housing the equipment like decoders, CATV modulators, amplifier and splitters.
- 9.6 The TV signals shall be distributed in digital ISDB-T standard (fully complying with the Brazilian standard) or IPTV.
- 9.7 All TVs shall have an internal decoder or an external decoder shall be provided.
- 9.8 01 (one) pay-TV decoder shall be provided in PETROBRAS' Representative cabin (bedroom).

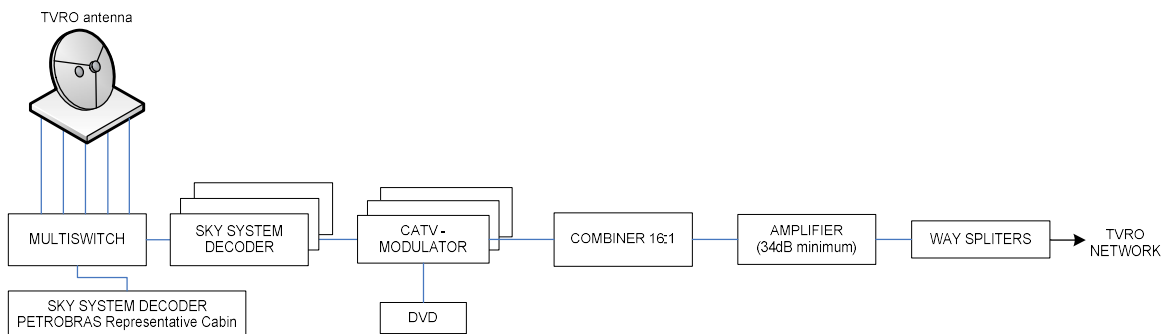

Figure 4: TVRO system general arrangement

10. UHF TV SYSTEM

- 10.1 A specific TV system shall be designed to tune in UHF TV signals generated by special service vessels (like PSV, DSV, AHTS), during their operation with the Unit. Only 01 (one) display in the CCR shall receive this signal. The receiver shall tune the whole UHF frequency band, as shown below.

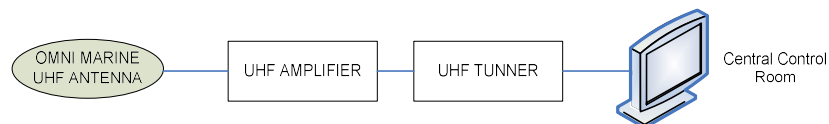

Figure 5: UHF TV system general arrangement

11. CONTRACTOR TELEPHONE SYSTEM

- 11.1 The description below aims to establish the requirements for CONTRACTOR TELEPHONE SYSTEM in the process areas, accommodation areas, offices, warehouses, and machinery spaces.
- 11.2 To support the PETROBRAS staff, the Unit shall have at least:
- 02 (two) CONTRACTOR's extensions line installed in each PETROBRAS' office,
 - 01 (one) extension line installed in each PETROBRAS' cabin

TITLE:

TELECOM MASTER SPECIFICATIONS FOR FPSO CHARTERED

c. 01 (one) extension line in PETROBRAS' videoconference room.

11.3 The Unit shall provide telephone booths with extension lines destined to private calls through the Brazilian public network, for use of the personnel onboard, in number according with Brazilian Regulatory Standard of the Ministry of Labor NR-37. Each one of these telephones shall be placed in a closed cabinet providing full privacy.

12. PETROBRAS STRUCTURED VOICE AND DATA NETWORKS

12.1 The description below aims to establish the requirements of Local Area Network (LAN) in accordance with the requirements of ANSI/EIA/TIA 568-B2-1 and ISO 11801 for CAT 6 multimedia (voice and data) communications for PETROBRAS exclusive use.

12.2 The network shall be designed in a star topology.

12.3 All LAN outlets and cables shall be properly labeled to be distinguished from CONTRACTOR network.

12.4 The Structured Cabling Network shall cover the following areas:

- a. 03 points to each PETROBRAS' workstation in PETROBRAS' office;
- b. 01 point in PETROBRAS' Representative office for printer;
- c. 03 points from CONTRACTOR's supervisory server Rack (to connect with PETROBRAS' PI server);
- d. 03 points in the Central Control Room;
- e. 03 points in the Radio Room;
- f. 02 points in emergency control room
- g. 03 points in PETROBRAS Telecommunications Room;
- h. 03 points in the Hospital;
- i. 01 point in the Treatment room
- j. 02 points in the storekeeper's office;
- k. 01 point in each telephone booth;
- l. 04 points in PETROBRAS' meeting room (used as Videoconference Room)
- m. 02 points in each PETROBRAS' cabins;
- n. 01 point to the AIS Transponder (RS-232/ethernet converter);
- o. 04 points in each PETROBRAS' dayroom for PETROBRAS' Representative;
- p. 03 points inside the Metocean Data Acquisition System (ENV) system rack;
- q. 06 points interconnecting PETROBRAS and CONTRACTOR LAN racks;
- r. 10 points interconnecting PETROBRAS' Racks.
- s. 03 points inside the POS system rack;
- t. 03 points inside the RRMS system rack;
- u. 03 points inside the MODA system rack;
- v. 01 point for each PETROBRAS access point;
- w. 06 points in SEISMIC control room;
- x. 03 points in SEISMIC Instrument room.



TITLE:

TELECOM MASTER SPECIFICATIONS FOR FPSO CHARTERED

- 12.5 Areas outside the accommodation, in the industrial area or areas where cable lengths exceed 100 meters shall be cabled with optical fiber according to ANSI/EIA/TIA 568-B3, as described below.
- Optical fiber cable with 6 fibers 62.5 x 125 with SC optic termination.
 - Fiber Optic shall be terminated in proper optical patch panel with SC termination and media converter (FastEthernet RJ-45 electrical to SC optical termination) 19" rack standard inside PETROBRAS Rack.
 - It shall be installed in the end of fiber cable a media converter (FastEthernet RJ-45 electrical to optical SC termination) to allow the connection with a workstation or telephone through UTP patch cord. The optic converters shall be housed in appropriated box and compatible with switch interface port speed.
 - Enough SC to SC optical cords shall be provided for both ends of such points.
- 12.6 All individual LAN cables from RJ 45 outlets shall be wired to the patch panels installed in PETROBRAS network rack.
- 12.7 PETROBRAS Structured Cabling Network shall be certified and an evidential report shall be submitted to PETROBRAS.
- 12.8 UTP Category 6 Cabling**
- Twisted pair cable (UTP) shall comply with the requirements of ANSI/EIA/TIA 568-B2-1 and ISO 11801 for Category 6 (CAT6).
 - The LAN cabling system shall use LSZH (Low Smoke Zero Halogen) UTP CAT 6 cable or other submitted for PETROBRAS approval.
 - All UTP CAT 6 horizontal cabling shall be connected to the CAT 6 Patch Panels with 24 positions (1U high) in the rack in the Telecommunications Room.
 - All the UTP cables shall have both ends identified. All the other components of the network shall be identified in the same way: patch panel, fiber optic cables, patch cords and sockets.
 - All connections shall be according to EIA/T568-A standard.
- 12.9 CAT 6 RJ 45 Female Connectors**
- The RJ 45 female connectors shall comply with the requirements of Standard ANSI/EIA/TIA 568-B2 Category 6 and shall be used as access points in the work areas (outlets).
- 12.10 CAT 6 Patch Panel**
- The Patch Panel shall be metallic with 19 inches width, according to ANSI/TIA/EIA-310D, with 24 RJ-45 female ports and 1U of height. It shall be placed in the PETROBRAS racks in Telecommunication Room.

TITLE:
TELECOM MASTER SPECIFICATIONS FOR FPSO CHARTERED
12.11 LAN Switches

- 12.11.1. CONTRACTOR shall provide, install and configure 03 (three) switches CISCO Model C9300L-48P-4G-A or superior by the time of purchasing with 04 (four) SFP interfaces each one for PETROBRAS exclusive use.
- 12.11.2. CONTRACTOR shall provide 04 (four) SFP GLC-SX-MM for each switch.
- 12.11.3. CONTRACTOR shall provide 06 (six) Fiber optic pig tail LC/PC with 3 meters.
- 12.11.4. CONTRACTOR shall provide 100 (a hundred) CAT6 patch cords of 02 (two) meters each (blue color).
- 12.11.5. CONTRACTOR shall provide 100 (a hundred) CAT6 patch cords of 02 (two) meters each (green color).
- 12.11.6. All LAN switches shall be powered by UPS unit.
- 12.11.7. CONTRACTOR will be responsible for equipment basic configuration with all parameters provided by PETROBRAS during the project detailed.
- 12.11.8. The firmware version required for data equipment shall be the latest version available by manufacturer during the commissioning phase.

12.12 Router

- 12.12.1. CONTRACTOR shall provide, install and configure 02 (two) CISCO ISR4431/K9 or superior by the time of purchasing for PETROBRAS exclusive use, with the following specs (for each router):

Product	Description	Quantity
ISR4431/K9	Cisco ISR 4431 (4GE,3NIM,8G FLASH,4G DRAM,IPB) with UC License	1
MEM-4400-4GU8G	4G to 8G DRAM Upgrade (4G+4G) for Cisco ISR 4400	1
CAB-SS-V35MT	V.35 Cable, DTE Male to Smart Serial, 10 Feet	2
MEM-FLSH-8U16G	8G to 16G eUSB Flash Memory Upgrade for Cisco ISR 4430	1
NIM-2T	2-Port Serial WAN Interface card	1
PWR-4430-AC/2	AC Power Supply (Secondary PS) for Cisco ISR 4430	1
CAB-C13-ACB	AC Power Cord (Brazil), C13, NBR 14136, 2.1M	2
CAB-CONSOLE-RJ45	Console Cable 6ft with RJ45 and DB9F	1
CAB-CONSOLE-USB	Console Cable 6ft with USB Type A and mini-B	1
SISR4400UK9-166	Cisco ISR 4400 Series IOS XE Universal	1
GLC-SX-MMD	Cisco 1000BASE-SX SFP transceiver module	2

Table 2: router specs

- 12.12.2. All routers shall be powered by UPS unit
- 12.12.3. CONTRACTOR will be responsible for equipment basic configuration with all parameters provided by PETROBRAS during the project detailed.
- 12.12.4. The firmware version required for data equipment shall be the latest version available by manufacturer during the commissioning phase.

12.13 PETROBRAS SERVERS

- 12.13.1. CONTRACTOR shall provide and install 04 (four) SERVERS, for PETROBRAS exclusive use, with the following specifications (for each server):
- 19" rack-mountable servers, with maximum height of 1U;



TITLE:

TELECOM MASTER SPECIFICATIONS FOR FPSO CHARTERED

- b. 2x processors (12) twelve-core from AMD EPYC, Intel Xeon Scalable or better ;
- c. 256 GB, installed - DDR4 UDIMM 2666 Mhz or better Expansible until 512 GB or better, all memories modules for 16 GB – DDR4, or better;
- d. 01 (one) or more SVGA output, with DB-15 connector;
- e. 04 (four) or more USB 2.0 inputs;
- f. 01 (one) SAS RAID Controller, capable of implementing RAID 0 and 1 independent;
- g. 02 (two) SAS Hard Disk Drives, Hot-Swap, 10k RPM, 600GB;
- h. 03 (three) SAS Hard Disk Drives, Hot-Swap, 10k RPM, 1.2TB;
- i. 04 (four) or more 1-Gb Ethernet network interfaces, auto-sense, with RJ-45 connector;
- j. 01 (one) general purpose RS-232 interface, with DB-9 connector;
- k. 02 (two) power supplies, hot-plug and redundant, AC input, 110-220V, 50-60Hz, at least 90% efficiency;
- l. 01 (one) optical drive, capable to read CD-ROM and DVD-ROM;
- m. Sliding rails and cable management arm;
- n. Ethernet/IP-based integrated graphical remote console.
- o. The servers must be certified by Microsoft (HCL), Red Hat and VMware for the two latest major versions of the following products at delivery time:
 - i. Windows Server;
 - ii. Red Hat Enterprise Linux;
 - iii. VMware ESXi. “Compatible operating system” with the last three major versions of ESXi”.
- p. The Operating System and licenses shall not be provided.
- q. Provide all the peripheral, hardware and software (including Medias and licenses) needed to install the servers.
- r. All configuration parameters and proposed procedures must be documented and delivered with the equipment. These documents may be delivered digitally (CD, DVD, Flash drive, or by download).

12.14 PI INTERCONNECTION

12.14.1. Firewall

12.14.1.1. CONTRACTOR shall provide two (02) firewalls from Fortinet manufacturer model Fortigate 80F or better from same vendor with all software licenses including IPS, Anti-Virus, Webfiltering and secure SD-WAN solution:

12.14.1.2. Interfaces:

- i. 2x GE RJ45/SFP Shared Media Ports
- ii. 2x WAN GE RJ45 Port
- iii. 6x GE RJ45 Ports
- iv. 2x GE RJ45* FortiLink Port

TITLE:

TELECOM MASTER SPECIFICATIONS FOR FPSO CHARTERED

12.14.1.3. Power supply:

- i. 12V DC, 3A with dual redundancy.

12.14.1.4. Accessories:

- i. 19in Rack mount tray

12.14.1.5. All firewalls shall be powered by UPS unit

12.14.1.6. CONTRACTOR will be responsible for equipment basic configuration with all parameters provided by PETROBRAS during the project detailed.

12.14.1.7. The firmware version required for data equipment shall be the latest version available by manufacturer during the commissioning phase.

12.14.2. DMZ SWITCH

12.14.2.1. CONTRACTOR shall provide and install 02 (two) switches CISCO Model C9300L-24T-4G-E or superior for PETROBRAS exclusive use.

12.14.2.2. CONTRACTOR will be responsible for equipment basic configuration with all parameters provided by PETROBRAS during the project detailed.

12.14.2.3. The firmware version required for data equipment shall be the latest version available by manufacturer during the commissioning phase.

12.14.2.4. DMZ switch shall be powered by UPS unit.

12.14.3. PI TOPOLOGY

12.14.3.1. Following below the PETROBRAS topology standardized for PI interconnection between PETROBRAS network and CONTRACTOR network.

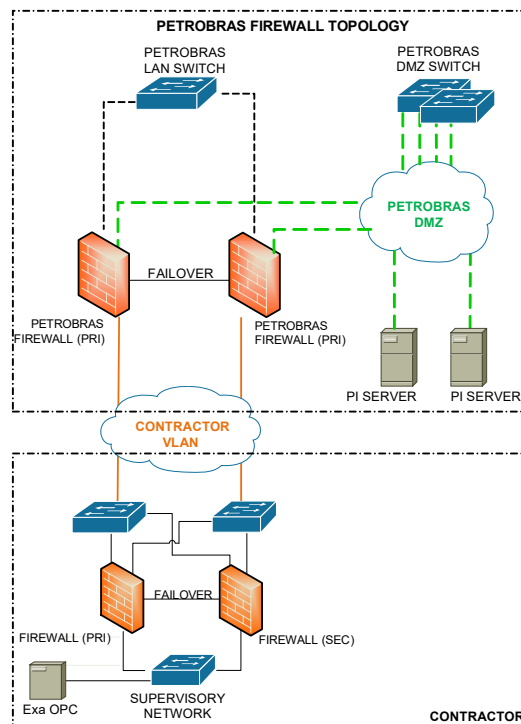

Figure 6: PETROBRAS PI interconnections to CONTRACTOR



TITLE:

TELECOM MASTER SPECIFICATIONS FOR FPSO CHARTERED

13. PETROBRAS TELEPHONE SYSTEM

- 13.1 PETROBRAS telephone system shall be based on IP telephony. Contractor shall provide the following telephone kit for PETROBRAS telephony solution:
- 13.2 CONTRACTOR shall provide the following equipment manufactured by UNIFY:
- 20 (twenty) OpenStage 15 SIP or OpenScape Desk Phone 35G SIP or CP-200-SIP models.
 - 05 (five) OpenStage 40 G SIP or OpenScape Desk Phone 55G SIP or CP-600-SIP models.
- 13.3 PETROBRAS will be responsible for these equipment configurations.

14. INMARSAT

- 14.1 CONTRACTOR shall supply and install a complete Inmarsat Fleet Broadband for voice and data contingency communication service segregated of the main circuit, which shall be installed in the Radio Room. It is supposed to be used any time by PETROBRAS and CONTRACTOR, if the main external VSAT system fails.

15. PETROBRAS WIRELESS LAN – WLAN

- 15.1 CONTRACTOR shall provide, install and configure a Wireless Local Area Network (WLAN) for PETROBRAS exclusive use, standard IEEE 802.11ax (WiFi 6), with coverage in the following areas inside the accommodation module:
- PETROBRAS representative office;
 - PETROBRAS technical office;
 - PETROBRAS day-room;
 - PETROBRAS videoconference room;
 - PETROBRAS representative cabin;
 - PETROBRAS Cabins
 - Emergency Control Room
 - CCR.
- 15.2 The WLAN shall be composed for the following equipment and comply with the following requirements:
- 15.2.1. **APs (Access Points)**
- The wireless equipment shall be compliance with Brazil Regulatory Domain.
 - In order to comply with PETROBRAS network requirements equipment shall be manufactured by CISCO.
 - All equipment shall be homologated by ANATEL.
 - APs (Access Points) shall be Cisco Catalyst 9100 Access Points or superior with Cisco DNA Essentials with subscription term for 07 years;



TITLE:

TELECOM MASTER SPECIFICATIONS FOR FPSO CHARTERED

- e. APs (Access Points) shall be connected to PETROBRAS switches and powered by PoE (Power over Ethernet);
- f. APs (Access Points) installed more than 90m from the switch shall be used fiber optic cables connected to optic/Ethernet converters and AC powered.
- g. The authentication of users and APs will be made by the controller in PETROBRAS existing RADIUS server onshore.
- h. Coverage shall be dimensioned to enable data rates of 24Mbps at minimum. A site survey report shall be issued by CONTRACTOR showing the required coverage.
- i. CONTRACTOR will be responsible for equipment basic configuration with all parameters provided by PETROBRAS during the project detail.

15.2.2. WLAN Controller

- a. WLAN Controller shall be C9800-L-C-K9 Series Wireless Controller with Cisco DNA Essentials for up to 25 Cisco access points, and 19" rack mounted kit.
- b. CONTRACTOR will be responsible for equipment basic configuration with all parameters provided by PETROBRAS during the project detailed.
- c. The firmware version required for data equipment shall be the latest version available by manufacturer during the commissioning phase.

16. PETROBRAS TELECOMMUNICATION ROOM

- 16.1 CONTRACTOR shall provide a properly room, 9 m2 minimum area, redundant air-conditioned, for installation of PETROBRAS' telecommunication equipment.
- 16.2 It will be acceptable to share with CONTRACTOR the same Telecommunication room.
- 16.3 CONTRACTOR shall provide and install cable trays in the PETROBRAS Telecommunication Room for adequate equipment installation.
- 16.4 CONTRACTOR shall provide and install 01 (one) 2/0 AWG bare copper cable in the Telecommunication Room for the electrical grounding of equipment.
- 16.5 In this room shall be installed the following:
 - a. 03 (three) Racks for PETROBRAS exclusive use (according to item 17);
 - b. DC Switchboard;
 - c. 220 VAC Switchboard.

17. CLOSED RACKS FOR VOICE AND DATA NETWORK

- 17.1 CONTRACTOR shall supply and install 03 (three) Racks for PETROBRAS voice and data network.
- 17.2 Racks shall be closed, 19 inches standard, 40U height, minimum depth of 1000 mm (internal dimensions) and 800 mm of useful width (internal dimensions).
- 17.3 Racks shall have AC universal standard sockets 19 inches standard and fan;
- 17.4 The following equipment shall be installed in **WAN - Rack 01**:
 - a. 02 (two) routers

TITLE:

TELECOM MASTER SPECIFICATIONS FOR FPSO CHARTERED

- b. 01 (one) WLAN controller
- c. 02 (two) 3rd Parties firewalls
- d. 02 (two) 3rd Parties DMZ switches
- e. 02 (two) PI servers;
- f. 02 (two) PI firewalls
- g. 02 (two) DMZ Switch
- h. Patch panel for interconnection with other PETROBRAS' racks (05 points to each);
- i. Patch panel for interconnection with CONTRACTOR VSAT rack (02 points);
- j. 01 (one) 19 inches DC switchboard
- k. 01 (one) 19 inches AC switchboard
- l. AC service outlets with at least 06 (six) positions.
- m. 01 (one) ATS

17.5 The following equipment shall be installed in **Rack 02**:

- a. 03 (three) corporate LAN Switches;
- b. 02 (two) corporate servers;
- c. PETROBRAS voice and data patch panels;
- d. Patch panel for interconnection with other PETROBRAS' racks (05 points to each);
- e. Patch panel for interconnection with CONTRACTOR PI rack (04 points);
- f. 01 (one) 19 inches DC switchboard;
- g. 01 (one) 19 inches AC switchboard;
- h. AC service outlets with at least 06 (six) positions;
- i. 01 (one) ATS.

17.6 The following equipment shall be installed in **Rack 03**:

- a. 01 (one) optical amplifier (supplied by PETROBRAS);
- b. 01 (one) DWDM equipment (supplied by PETROBRAS);
- c. 01 (one) 19 inches DC switchboard;
- d. 01 (one) 19 inches AC switchboard;
- e. Optical patch panel for fiber optics from submarine optic cable;
- f. Patch panel for interconnection others PETROBRAS' racks (05 points to each);
- g. AC service outlets with at least 06 (six) positions;
- h. 01 (one) ATS.

17.7 Proposed drawing for PETROBRAS telecommunication racks:

TITLE:

TELECOM MASTER SPECIFICATIONS FOR FPSO CHARTERED



Figure 7: typical layout for PETROBRAS racks

18. PETROBRAS VIDEOCONFERENCE SYSTEM

18.1 PETROBRAS Videoconference Room

18.1.1. CONTRACTOR shall provide a meeting room that will also be used as a videoconference room by PETROBRAS. This room shall be in the same deck as the PETROBRAS' Representative office and as close as possible to it. The room shall have a minimum area of 12 m2.

18.1.2. The following requirements shall be considered:

- a. Noise: the room shall be submitted to an acoustic treatment, so that the maximum internal noise level does not exceed 70 dB-SPL (70 dBA);
- b. Lighting: it is recommended that the meeting room be illuminated by homogeneous lighting, preferably using fluorescent lamps with color temperature between 3200 °K and 5600 °K. The use of light sources such as incandescent lamps or day light (window), mixed to the fluorescent illumination shall be avoided;
- c. Luminous Intensity: it is recommended that the luminous intensity be in the 600 to 800 Lux range;



TITLE:

TELECOM MASTER SPECIFICATIONS FOR FPSO CHARTERED

- d. Colors: Shiny colors shall be avoided in the walls and floor;
 - e. Air-conditioning: the room shall be covered by the accommodations central VAC system. Portable air-conditioning systems or the internal units of split systems shall be avoided;
 - f. Meeting table: 03 (three) PETROBRAS LAN sockets and 04 (four) 220 VAC power sockets shall be provided in the middle of the table.
- 18.1.3. 03 (three) 220 VAC power sockets shall be provided near the videoconference equipment and TVs;
- 18.1.4. 01 (one) PETROBRAS LAN socket shall be provided near the CODEC videoconference equipment.
- 18.2 PETROBRAS Videoconference Room Equipment
- 18.2.1. CONTRACTOR shall supply and install the following equipment in the videoconference room, complying with PETROBRAS' videoconference network:
- a. 01 (one) POLY STUDIO X50 solution or more recent model with licenses to act as MICROSOFT TEAMS MTR (Microsoft Teams Room) Small/Medium Room Kit solution or as a normal CODEC to be defined by PETROBRAS.
 - b. It shall be supplied with accessories and licenses in order to allow content exchanges.
 - c. The POLY Small/Medium Room Kit shall include:
 - i. Poly Studio USB camera,
 - ii. GC8 touch controller,
 - iii. Cable 10m USB3.1 A to C,
 - iv. Poly Room kit PC. Dell Optiplex 7080 XE
 - v. Wall/VESA Mount
 - d. CONTRACTOR shall confirm with PETROBRAS the manufacturer and model during the detailed design.
 - e. The firmware version required for this equipment to be connected in the PETROBRAS NETWORK will be informed by PETROBRAS during the project detailed.
 - f. 01 (one) microphone installed on the table described in item 18.1.2.f.
 - g. 02 (two) 65 inches LED TV wall mounted side by side with interfaces compatible with CODEC.
 - h. 10 meters HDMI cable to connect CODEC to PETROBRAS Notebook.
 - i. 01 HDMI/VGA adapter.
- 18.2.2. PETROBRAS will be responsible for this equipment configuration.
- 18.2.3. Following the videoconference room design proposal.

TITLE:

TELECOM MASTER SPECIFICATIONS FOR FPSO CHARTERED



Figure 8: videoconference room layout

18.3 Hospital Videoconference Equipment

18.3.1. CONTRACTOR shall supply and install another videoconference system in the Hospital, as follow:

- a. 01 (one) POLY STUDIO X50 solution for MICROSOFT TEAMS or a more recent model, with accessories and licenses in order to allow content exchanges;
- b. CONTRACTOR shall confirm with PETROBRAS the manufacturer and model during the detailed design.
- c. The firmware version required for this equipment to be connected in the PETROBRAS NETWORK will be informed by PETROBRAS during the project detailed.
- d. 01 (one) 40 inches LED TV wall mounted with interfaces compatible with CODEC;
- e. 10 meters HDMI cable to connect CODEC to PETROBRAS Notebook;
- f. 01 HDMI/VGA adapter;
- g. 01 Pedestal (CART) for TV and videoconference equipment installation;
- h. Videoconference equipment shall be arranged in Hospital or Treatment Room so that camera can focus on injured patient on stretcher and doctor.

18.3.2. PETROBRAS will be responsible for this equipment configuration.

18.3.3. Following the typical videoconference pedestal:



Figure 9: videoconference pedestal in Treatment Room



TITLE:

TELECOM MASTER SPECIFICATIONS FOR FPSO CHARTERED

19. INTEGRATED PETROBRAS AND CONTRACTOR VSAT SOLUTION

- 19.1 CONTRACTOR shall supply and install an integrated Ka-band VSAT solution based on O3b mPower from SES technology or similar for PETROBRAS and CONTRACTOR shared use, compound by 03 (three) stabilized antennas.
- 19.1.1. CONTRACTOR must install an additional VSAT link in order to increase availability of its VSAT solution.
- 19.2 CONTRACTOR will be responsible to contract a Ka-band VSAT circuit with at least 50Mbps (25Mbps uplink + 25Mbps downlink) to be shared with PETROBRAS as following:
- CONTRACTOR 30Mbps (15Mbps uplink + 15Mbps downlink)
 - PETROBRAS 20Mbps (10Mbps uplink + 10Mbps downlink)
 - The circuit shall have availability equal or greater than 98.5% per month.
 - The circuit shall present bit error rate (BER) better than 10⁻⁹.
 - Circuit shall present maximum end-to-end Round Trip Time delay of 180ms;
 - CIR (committed information rate) = 60%
 - EIR (Excess Information Rate) = 10%
- 19.3 CONTRACTOR shall be responsible for contract the satellite provider including all costs regarding to this service and the dedicated circuit from the satellite Provider HUB to PETROBRAS base station during all period of the FPSO contract.
- 19.4 During the detail design, PETROBRAS will advise which PETROBRAS onshore base station will be used to connect the onshore circuit ends.
- 19.5 The satellite provider shall be responsible for satellite circuit licensing according to Brazilian legislation.
- 19.6 The circuit provider shall perform a survey in PETROBRAS base station previously to the installation and activation of the circuit. The interface between VSAT PROVIDER and PETROBRAS equipment shall be agreed during the survey. The required interface cable is under responsibility of the circuit provider.
- 19.7 VSAT system shall be assembled, configured and tested by CONTRACTOR at shipyard.
- 19.8 Vendor representative technician in Brazil shall commission the system as soon as the unit arrives in Brazil.
- 19.9 CONTRACTOR shall inform PETROBRAS at least 60 days before the tests and inspections to be performed in the shipyard.
- 19.10 The pedestal for VSAT antenna installation shall guarantee a safety access for telecom technician.
- 19.11 The communication between CONTRACTOR's CPE router and PETROBRAS's router onboard shall be made with an IP subnet with /30 mask to be informed by PETROBRAS.

20. LAST MILE CIRCUITS REQUIREMENTS

- 20.1 Once PETROBRAS VSAT communications reach the onshore Provider satellite station (HUB), CONTRACTOR shall provide onshore MPLS links from HUB to 02 (two) PETROBRAS sites.



TITLE:

TELECOM MASTER SPECIFICATIONS FOR FPSO CHARTERED

20.2 The CONTRACTOR shall be responsible to provide onshore MPLS communication between the onshore satellite station and two connection points at PETROBRAS, and shall have the characteristics below:

- a. The last-mile circuits that connect the telecom provider teleport to the others two PETROBRAS's sites can transfer data from/to one or more vessels. The design of those circuits is CONTRACTOR's responsibility.
- b. The last-mile circuits shall have different physical routes in two different PETROBRAS's connection sites. The options available for connection with PETROBRAS network are listed below:

	Base Onshore	Endereços
1	Macaé/Imbetiba	Avenida Elias Agostinho, 66, Imbetiba, Macaé - RJ
2	CIPD - RJ	CENPES – Av. Horácio Macedo, 950 - Cidade Universitária, Rio de Janeiro - RJ
3	EDISE - RJ	Avenida República do Chile, 65, Centro, Rio de Janeiro – RJ

Table 3: PETROBRAS allowed addresses

- c. The first Layer 3 device connected to the PETROBRAS's CE (Customer Edge) shall have dynamic routing protocol. CONTRACTOR can choose between one of the protocols RIPv2, OSPFv2 and BGPv4.
- d. CONTRACTOR is responsible for licensing all telecommunications systems at the competent regulatory agencies and shall provide all of them to PETROBRAS.

20.3 Each MPLS last-mile circuit to be provided by the CONTRACTOR shall present minimum requirements of performance as follows:

- a. CONTRACTOR's topology shall comply with RFC 4364 and RFC 3031.
- b. CONTRACTOR shall provide exclusive routing instance for PETROBRAS use (exclusive VRF).
- c. This exclusive VRF shall support layer 3 MPLS network.
- d. The circuits shall be delivered with a CPE router at each end, whose delivery is the responsibility of the provider selected by the CONTRACTOR.
- e. In onshore stations, PETROBRAS may choose to connect the CPE routers, provided by the PROVIDER, to a CE router or switch connected to the CE router of the PETROBRAS network.
- f. The communication between CONTRACTOR's CPE router and PETROBRAS's router shall be made with an IP subnet with /30 mask to be informed by PETROBRAS.

20.4 CPE Router basic characteristics, provided by the CONTRACTOR, are:

- a. Suitable WAN connection interface;
- b. Support to IP SLA feature;
- c. OSPFv2 and BGPv4 routing;
- d. Support to Ipv4 addresses;
- e. ICMP;

TITLE:

TELECOM MASTER SPECIFICATIONS FOR FPSO CHARTERED

- f. Managing: Telnet; SSH; SNMP v2 and v3; MIB II; RMON;
 - g. QoS (DiffServ);
 - h. Support to identification, tagging, prioritization in accordance with CoS and DSCP fields;
 - i. Support to packet classification based in: source and/or destination IP address, range of source and/or destination ports, and transport protocol;
 - j. Support to unqueue mechanism of SP (Static Priority) and CBWFQ, having at least one priority queue or type SP;
 - k. Throughput allocation to each queue in terms of percentage of the interface throughput;
 - l. Traffic policy to each queue, allowing discard in case of excess of bandwidth consumption;
 - m. The equipment (hardware and software) provided by the CONTRACTOR shall be in the most stable and updated version;
 - n. The CPE shall support the queue and policing mechanisms for low latency queue of the Queue #1 (for example: LLQ, PQ or similar) and an algorithm for minimum resources assurance for Queues #2, 3 and 4 (for example: CBWFQ, WRR or similar).
 - o. The CPE shall be dimensioned to support not only the traffic, but also the additional processing caused by the tagging, in case of those tags do not match with CONTRACTOR's MPLS network.
 - p. The CPE provided by the CONTRACTOR shall the capacity to identify the packets tagging encapsulated in GRE tunnels, used between PETROBRAS's routers connected to the network.
 - q. The CPE shall support and be configured with the Class-Based Shaping characteristics to limit the bandwidth at the Ethernet interface connected to PETROBRAS equipment in an hierarchical way to the QoS politics.
- 20.5 The minimum end-to-end performance requirements, which comprises the path between the offshore unit until each PETROBRAS connection site onshore are:
- a. Transmission bandwidth: 20 Mbps
 - b. Round Trip Time (RTT): less than 250ms;
 - c. Bit Error Rate: Less than 10E-6;
 - d. Packet losses: less than 10E-3;
 - e. Committed Information Rate (CIR) equal to Maximum Information Rate (MIR);
 - f. The services shall support MTU (Maximum Transmission Unit) equal or higher than 1500bytes;
 - g. Support of identification, tagging, prioritizing according to DSCP field;
 - h. Throughput allocation to each queue in terms of percentage of the interface throughput;
 - i. Traffic policy to each queue, allowing discard in case of excess of bandwidth consumption.
- 20.6 The end-to-end network shall support:
- a. Diffserv (Differentiated Services);
 - b. Traffic management tools (including NetFlow or similar);
 - c. Voice and video traffic (Real Time);

TITLE:

TELECOM MASTER SPECIFICATIONS FOR FPSO CHARTERED

- d. IPsec VPN;
 - e. GRE VPN;
 - f. OSPFv2: Open Shortest Path First Version 2;
 - g. BGP;
 - h. Management: Telnet; SSH; SNMP v2 and v3; MIB II; RMON;
 - i. QoS (DiffServ);
 - j. Ipv4 addresses;
 - k. ICMP;
- 20.7 The network must offer 3 (three) DiffServ QoS queues:
- i. Queue 1 (Real Time);
 - ii. Queue 2 (Business Applications);
 - iii. Queue 3 (Internet, backup and others);
- 20.8 The tags below shall be preserved throughout the network (access links and transport network):
- 20.8.1. Queue 1 (Real Time Applications – Real Time);
- EF (voice) – mandatory dialing
 - AF41 (videoconference) – mandatory appointment
- 20.8.2. Queue 2 (Business applications)
- AF21 (SAP/R3) – mandatory marking
 - AF22 (Electronic Document Management, BDENQ) - desirable marking
 - AF23 (Lotus Notes) – desirable marking
 - AF31 (Automation) – mandatory marking
 - AF32 (WEBTV and SISP) – desirable marking
 - AF33 (Management and Routing) – Desirable Marking
- 20.8.3. Queue 3 (Internet, backup and others)
- DSCP 00 (Internet and Intranet) – mandatory tag
 - AF11 (Backup and Replication) – mandatory tag
 - All other tags – Tags desirable
- 20.9 The queues 2 and 3 can use other queues resources, in case these queues are free. However, queue 1 shall not use resources of the other queues.
- 20.10 The network shall make the necessary markings needed to adapt the QoS policies of the PETROBRAS network to the CONTRACTOR's network in both directions, ie, on the one way, it must mark a PETROBRAS QoS package for a new QoS package of the CONTRACTOR and the opposite way should mark from the CONTRACTOR's QoS to the PETROBRAS QoS.

TITLE:

TELECOM MASTER SPECIFICATIONS FOR FPSO CHARTERED

20.11 The bandwidth reserved for each queue should meet, in a flexible way, the following criteria:

Bandwidth of access link	Queue 1	Queue 2	Queue 3
Bandwidth	30%	30%	40%

Table 4: criteria for queues

20.12 All commissioning tests for acceptance of the end-to-end service shall have a minimum duration of 8 hours, and the following parameters shall be measured:

- a. MIR and CIR
- b. BER, Packet Error Rate and Latency
- c. For the MPLS circuit commissioning, the CONTRACTOR shall consider the measure points: PETROBRAS and Teleport of the telecom provider.
- d. For the vessel commissioning, CONTRACTOR shall consider as measure points: Teleport and Vessel.
- e. All tests shall comply with standards based on rules Y.1654 (ITU-T) and RFC 2544 (IETF).
- f. All reports shall be sent to PETROBRAS in order to confirm the achievement of the stablished requirements.

21. EQUIPMENTS SUPPLIED BY PETROBRAS

21.1 PETROBRAS will supply and install the following equipment:

- a. Optical amplifier;
- b. DWDW.

22. POWER SYSTEM

22.1 Contractor shall provide a DC power supply (-) 48VDC/ 100A (positive grounded) with the following main electrical characteristics:

- a. Rated input voltage = 220 VAC
- b. Rated output voltage = (-) 48 VDC
- c. Floating voltage (output) = -52.8 VDC
- d. Recharge voltage (output) = -57.6 VDC
- e. Final discharge voltage (output) = - 43.2 VDC

22.2 The system shall have 02 (two) batteries banks dimensioned to keep the system for 02 (two) hours at minimum.

22.3 DC Switchboard

22.3.1. It shall be provided 01 (one) 19 inches rack mounted -48 VDC switchboard in each PETROBRAS' Rack;

22.3.2. The switchboard shall be provided with 04 (four) 6 A circuit breakers and 04 (four) 10 A circuit breakers for racks 01 and 02.

TITLE:
TELECOM MASTER SPECIFICATIONS FOR FPSO CHARTERED

22.3.3. The switchboard shall be provided with 02 (two) 40 A circuit breakers and 02 (two) 10 A circuit breakers for rack 03.

22.4 AC Switchboard

22.4.1. It shall be provided 01 (one) 19 inches rack mounted AC switchboard in each PETROBRAS' rack.

22.4.2. The AC switchboards shall be fed by 220 VAC from UPS A and B (main and redundant) bus-bar using a ATS (Automatic Transfer Switch).

22.4.3. Each AC switchboard shall be provided with 10 (ten) 10 A circuit breakers.

22.4.4. Each equipment power source shall be fed by a dedicated circuit breaker inside racks.

22.4.5. These switchboards shall feed all equipment installed in PETROBRAS' Racks.

22.4.6. Each rack shall have 02 (two) 19 inches service outlets of at least 06 (six) sockets, installed at its rear, coming from a dedicated circuit breaker.

22.4.7. Proposed drawing for PETROBRAS power system inside racks.

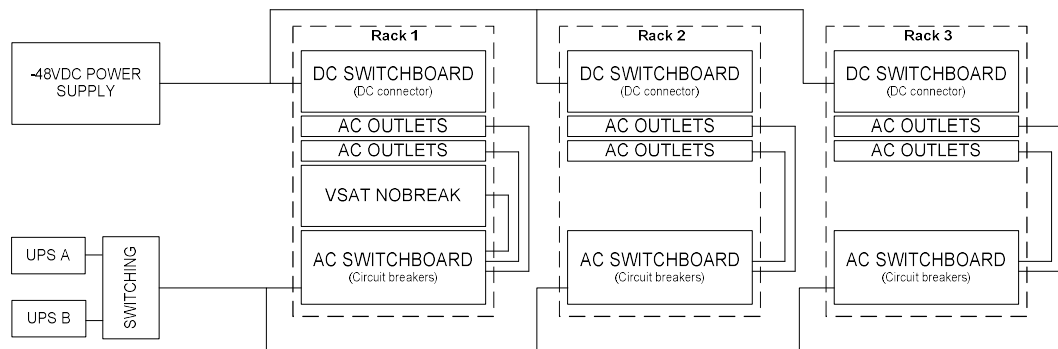

Figure 10: schematic power arrangement for PETROBRAS racks

23. CONTRACTOR TELECOMMUNICATION SYSTEM

23.1 CONTRACTOR shall provide its own voice and data communication systems for all its personnel onboard, including the communication with the onshore site.

24. DOCUMENTATION

24.1 The following documents shall be sent to PETROBRAS comments during the project:

24.1.1. Block diagrams and online diagrams:

- PETROBRAS VSAT system;
- PETROBRAS and CONTRACTOR Structured Cabling Network;
- PETROBRAS Videoconference system;
- PETROBRAS (-) 48 VDC power system;
- PETROBRAS racks arrangement;
- GMDSS system;
- Operational Radio System;

TITLE:

TELECOM MASTER SPECIFICATIONS FOR FPSO CHARTERED

- h. EPTA class M;
- i. UHF Active Repeater System;
- j. TVRO system;
- k. PAGA system;
- l. CCTV system;
- m. Telecommunications Power System;
- n. Power cabling connection ("from-to").

24.1.2. General Arrangement:

- a. Radio room;
- b. CCR;
- c. CONTRACTOR and PETROBRAS Telecommunications equipment room;
- d. Antenna deck lay-out;
- e. Accommodations including: client offices, client meeting/videoconference room; client cabins, telephones booths, hospital, treatment room;
- f. Battery room;
- g. CONTRACTOR and PETROBRAS Structured Cabling Network;
- h. PAGA;
- i. TVRO.

24.1.3. Additional documents

- a. Cable routing for UHF active repeater network;
- b. Approval certification of PAGA System form Classification Society;
- c. Certification report for Structured Cabling Network;
- d. Pre-commissioning procedure and report for PETROBRAS VSAT.

24.1.4. CONTRACTOR shall deliver to PETROBRAS a book with all as built documents related to PETROBRAS systems.

25. INFRASTRUCTURE FOR SUBMARINE FIBER OPTIC NETWORK

25.1 It shall be provided all proper infrastructure in order to connect the FPSO in the PETROBRAS submarine fiber optic network.

25.2 The following items shall be provided and installed by CONTRACTOR:

- a. One dedicated I tube for 01 (one) dedicated optic umbilical;
- b. It shall be installed 02 (two) fiber optic cables from PETROBRAS telecom room to riser Balcony area with the following specs:
 - i. 12 (twelve) fibers optics each one;
 - ii. single mode fiber optic type;

TITLE:
TELECOM MASTER SPECIFICATIONS FOR FPSO CHARTERED

iii. Cable insulation shall be Low Smoke Zero Halogen.

25.3 The fibers optics shall be according to ITU-T G series recommendations and the technical characteristics of recommendation G.652D.

25.4 On the 1550nm window, the fiber optic shall have the following characteristics:

- a. Attenuation less than or equal to 0.20 db/km
- b. Dispersion less than or equal to 18.00 ps/nm.km
- c. Dispersion Slope less than or equal to 0.088 ps/nm².km
- d. PMD less than or equal to 0.20 ps/ $\sqrt{\text{km}}$
- e. Effective area less than or equal to 76 μm^2

25.5 It shall be installed close to I-Tube destined to submarine optical cable pull-in, in riser balcony area, an Ex-d Junction Box to protect the optic splices between optic submarine cable and topside optic cable.

25.6 Such Ex-d Junction Box shall have 04 (four) cable glands: 02 (two) for fiber cables from JB to Telecom Room inside rack 03 and 02 (two) for submarine optical umbilical to JB, which must be let covered.

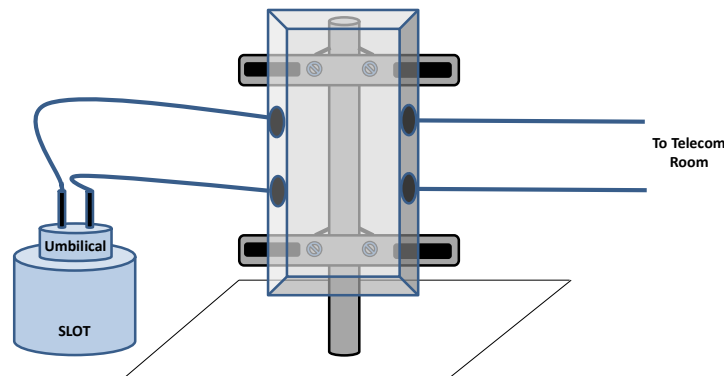

Figure 11: typical JB arrangement

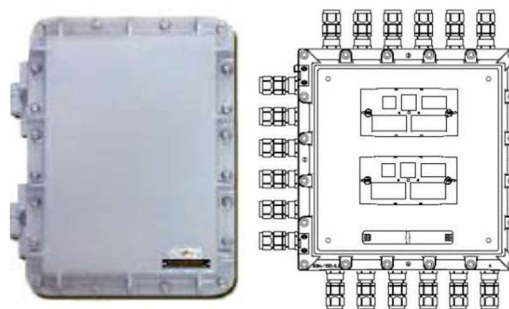

Figure 12: typical Ex-d Junction Box

TITLE:
TELECOM MASTER SPECIFICATIONS FOR FPSO CHARTERED

Figure 13: typical splice cassette for securing single optic fiber splices Installed inside the Ex-d Junction box

- 25.7 The cable route from selected I-TUBE (destined to submarine optical cable pull-in) to Ex-d Junction box shall be at most 05 meters length.
- 25.8 All fiber optic cables, inside the PETROBRAS Telecommunication Rack, shall be terminated in 01 (one) optical patch panel 19" inches with E2000/APC connectors.
- 25.9 The optical cables shall be installed in appropriated cable trays from riser balcony area to PETROBRAS Telecommunication Room, with no splice, to ensure that no mechanical stresses occur and as well as no curve greater than specified by the manufacturer.

26. LTE/4G SYSTEM

- 26.1 CPE - Customer Premises Equipment: Equipment installed on the client unit that establishes the LTE connection with the radio base station and internally distributes access to devices such as computers and network servers through UTP or wireless network.
- 26.2 eNodeB Evolved Node B: Term used for 4G or 5G technologies to indicate base stations.
- 26.3 The CPE System shall meet the requirements below:

MIMO Matrix Order, at least	2x2
Transmission Power, at least	23 dBm
Antennas Type	Omnidirecional
Antenna Gain, at least	5 dBi
100Base-T (RJ-45) ports, at least	6

Table 5: CPE System requirements

- 26.4 All equipment for external use, such as antennas and CPEs, when applicable, must be installed in a location that allows the maximum horizontal view without obstructions, such as: antenna deck, unit mast or in a dedicated mast provided by the CONTRACTOR.
- 26.5 All externally installed LTE equipment shall use all the necessary accessories for its fixation, adjustment and RF connection, in structures capable of withstanding, under operational conditions, weight loads and a wind speed of at least 100 km/h;
- 26.6 The CPE's LTE Frequency band shall meet ANATEL standards that allow the use of, at least:
 - a. 700 MHz on 5 MHz FDD (Frequency Division Duplex) channels, also known as LTE Band 28;
 - b. 1800 MHz on 5 MHz FDD (Frequency Division Duplex) channels, also known as LTE Band 3;
 - c. The CPE shall work in at least on the above frequencies, automatically choosing the best performance band.

- 26.7 The Unit's CPE System shall be able to connect to the eNodeB up to 20km away and be designed taking into account this distance and the use of eNodeB with RSSI (Received Signal Strength Indicator) equal to -100dBm, for LTE Band 28.
- 26.8 In order to guarantee wide coverage, avoiding possible obstacles and providing redundancy to the system, the contractor shall install at least 2 (two) CPE systems.
- 26.9 At the criteria of PETROBRAS' inspection, the CONTRACTOR shall prove that the losses resulting from the greater distance between the active elements and respective antenna sets do not affect the design requirements.
- 26.10 In order to avoid extra efforts on the connection of the RF cable to the antenna, the use of a flexible RF tail will be mandatory to make this connection.



Figure 14: typical flexible RF tail

27. RADIO ROOM

- 27.1 The FPSO shall have an exclusive radio room for the radio communication system.
- 27.2 In the Radio Room shall be installed the GMDSS radio console, operational radio console, CCTV monitor, Meteorological and Positioning System displays (HMS System), computer, and others radio equipment.

28. PRM SYSTEM – TELECOMMUNICATION INFRASTRUCTURE

- 28.1 Following below the telecommunications requirements for PRM – Permanent Reservoir Monitoring – System.

28.2 PRM SWITCH

- 28.2.1. CONTRACTOR shall provide and install 01 (one) switch CISCO Model WS-C3650-24PS-S or superior for PETROBRAS exclusive use.
- This switch shall be installed in PRM rack located in SEISMIC Instrument room.
 - CONTRACTOR will be responsible for equipment basic configuration with all parameters provided by PETROBRAS during the project detailed.
 - The firmware version required for this equipment to be connected in the PETROBRAS NETWORK will be informed by PETROBRAS during the project detailed.

28.3 LAN INTERCONNECTION

- 28.3.1. It shall be installed 05 (five) UTP cables from SEISMIC control room to SEISMIC Instrument room.
- SEISMIC Instrument room - These cables shall be terminated in patch panel in the same rack where the switch will be installed.
 - SEISMIC control room – These cables shall be terminated in sockets close of workstations

TITLE:

TELECOM MASTER SPECIFICATIONS FOR FPSO CHARTERED

c. In case of the distance require fiber optical cable it shall be foreseen RJ-45 to fiber converters

28.4 DIGITAL RADIO LINK

28.4.1. It shall be provided an adequate infrastructure to be installed a digital radio link, this infrastructure consists in:

- a. It shall be installed one pipe with 4 inch diameter and 3 meters height – The location will be defined during the project detail.
- b. It shall be pulled 02 (two) RF cable cellflex 7/8 inch 50 ohms from telecoms room rack 01 to the pipe described above.
- c. It shall be pulled 02 (two) STP cat-6 cables from telecoms room rack 01 to the pipe described above.

28.4.2. PRM Contractor will be responsible for the radio equipment supply and installation.

28.5 GPS SYSTEM

28.5.1. It shall be installed one GPS cable from the FPSO GPS buffer to SEISMIC Instrument room.

29. COMPUTERS AND PRINTERS

29.1 Contractor shall provide computers and printers for PETROBRAS exclusive uses:

29.1.1. Computers

29.1.1.1. It shall be supplied 08 (eight) computers with the minimum configuration below:

- a. Processor (CPU): i7 8th Generation, similar or superior;
- b. Operating System: Microsoft Windows 10 professional x64;
- c. RAM memory: 16GB DDR4
- d. Storage: 512 GB internal Solid State Drive (SSD)
- e. Video card with 2GB GDDR5 graphics memory
- f. Network adapter: 802.11ac 2.4/5 GHz wireless adaptor
- g. Monitor: 22" LCD monitor;
- h. I/O ports: 01 Audio in/out and Microphone Port; 01 VGA; 01 HDMI; 04 USB; 01 Network Port
- i. Accessories: DVD-RW, webcam, mouse, keyboard and speakers.

29.1.1.2. Additionally, it shall be supplied 02 (two) extra monitors for the PETROBRAS representative office.

29.1.1.3. CONTRACTOR shall send to PETROBRAS the invoice of the computers to prove that the Windows 10 professional version operating system license was acquired with the computers.

29.1.1.4. Computers shall have available features to be updated to WINDOWS next generation stated by Microsoft, if required during commissioning phase.

29.1.2. Printers

29.1.2.1. It shall be supplied 02 (two) Color Laserjet printers with the configuration below:

- a. Copy Resolution 600 x 600 dpi
- b. Network interface (LAN): RJ-45, Ethernet standard, TCP/IP V4 compatible (IPv4)
- c. Scanning with sending via email (SMTP)
- d. Standard 350 sheets capacity, at least.
- e. Paper Feed size A4 (210 × 297 mm)
- f. 05 toner of each color.

29.1.2.2. During the contract the toner replacement will be contractor responsibility.

30. DMZ FOR THIRD PARTY ACCESS

30.1 In order to guarantee the implementation of new services that demand the installation of servers of other companies without PETROBRAS management, CONTRACTOR shall provide, install and configure a DMZ for third party with the equipment described below:

30.2 FIREWALL

30.2.1. CONTRACTOR shall provide two (02) firewalls from Fortinet manufacturer model Fortigate 80F or better from same vendor with all software licenses including IPS, Anti-Virus and Webfiltering.

30.2.2. Interfaces:

- a. 2x GE RJ45/SFP Shared Media Ports
- b. 2x WAN GE RJ45 Port
- c. 6x GE RJ45 Ports
- d. 2x GE RJ45* FortiLink Port

30.2.3. Power:

- a. 12V DC, 3A with dual redundancy.

30.2.4. Accessories:

- a. Rack mount tray

30.3 SWITCHES

30.3.1. CONTRACTOR shall provide two (02) switches CISCO Catalyst C1000-24T-4G-L model, or superior for use in future demands for integration of third-party network to the PETROBRAS network.

30.3.2. All these equipment shall be installed inside the PETROBRAS rack 01;

30.3.3. Following below the typical topology.

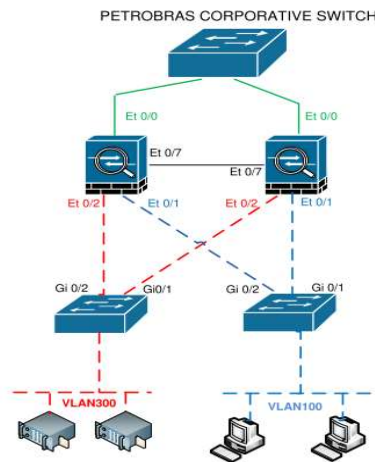
TITLE:
TELECOM MASTER SPECIFICATIONS FOR FPSO CHARTERED

Figure 15: typical topology for 3rd parties access
31. CONTRACTOR CCTV SYSTEM

- 31.1 CONTRACTOR shall install a Closed Circuit TV system to monitor the Unit. All camera signals shall be provided in the CCR in Full HD resolution.
- 31.2 All camera signals shall be recorded at continuous mode and images must have a minimum retention period of 30 days, recording at minimum 15 frames per second at maximum resolution.
- 31.3 CONTRACTOR shall foresee the CCTV cameras to monitoring, at least, the pump room, engine room, panels room, main deck, flare, cargo deck areas, offloading area, lifeboat loading areas, embarkation areas, CCR and the main and strategic systems in the topside modules.
- 31.4 Specific thermal cameras shall be provided to monitor possible oil spills to the sea. The cameras shall be located to maximize coverage area and include possible spill scenarios from risers.
- 31.4.1. The riser connection deck shall be monitored by at least 04 (four) dedicated thermal cameras.
- 31.4.2. At least one thermal camera shall be provided to monitor the offloading operation (oil transfer to shuttle tankers) at each offloading station.
- 31.4.3. A thermal camera shall also monitor flare flame.
- 31.4.4. Monitoring shall be based on cameras with thermal vision capacity in the LWIR - 8um a 13,5um minimum range and resolution of 640x480 pixels.
- 31.5 It shall be installed a CCTV monitor and keyboard in PETROBRAS representative office and Work permission room with privileges to live and playback monitoring e PTZ camera control.

32. CONTRACTOR INDUSTRIAL WIRELESS NETWORK

- 32.1 Contractor shall provide coverage in all industrial areas in its Wi-Fi network. CONTRACTOR can also choose LTE technology. It will be used by PETROBRAS in future mobile applications.
- 32.2 Additionally, CONTRATOR shall provide:
- 32.2.1. 02 (two) Ex zone 1 mobile cameras with helmet accessories;
- a. Ex zone 1 certified;

TITLE:

TELECOM MASTER SPECIFICATIONS FOR FPSO CHARTERED

- b. Dual band WiFi (2,4 GHz and 5 GHz);
- c. Integrated digital microphone with noise cancellation;
- d. Bluetooth support for headsets;
- e. 1080P 30fps Full Duplex Video;
- f. 32 GB internal storage.

32.2.2. 04 (four) Ex zone 1 tablets, with minimum specs below:

- a. Processor Quad core 1,2 GHz minimum
- b. Ex zone 1 certified;
- c. LTE & WiFi;
- d. 8" display;
- e. Android Operational system;
- f. Front and rear Camera;
- g. 64 GB internal storage.

32.2.3. 04 (four) Ex zone 1 smartphones, with minimum specs below:

- a. Processor Quad core 1,2 GHz minimum
- b. Ex zone 1 certified;
- c. LTE & WiFi;
- d. 5" display;
- e. Android Operational system;
- f. Front and rear Camera;
- g. 32 GB internal storage.