	TECHNICAL SPECIFICATION		Nº: I-ET-3010.1M-1350-190-P4X-001							
	CLIENT:	SRGE	SHEET					1	of	56
	JOB:	REFERENCE BASIC DESIGN	1001056398 0010							
	AREA:	BÚZIOS								
DP&T-SRGE	TITLE: ACCOMMODATION ARCHITECTURE MATERIALS AND EQUIPMENT SPECIFICATION		NP-2							
				ESUP						
MICROSOFT WORD / V. 2013 / I-ET-3010.1M-1350-190-P4X-001_0.DOCX										
INDEX OF REVISIONS										
REV.	DESCRIPTION AND/OR REVISED SHEETS									
0	ORIGINAL ISSUE									
	REV. 0	REV. A	REV. B	REV. C	REV. D	REV. E	REV. F	REV. G	REV. H	
DATE	JUN.11.2019									
DESIGN	ESUP									
EXECUTION	GWERNECK									
CHECK	LÍDIA									
APPROVAL	LUCIANARM									
INFORMATION IN THIS DOCUMENT IS PROPERTY OF PETROBRAS, BEING PROHIBITED OUTSIDE OF THEIR PURPOSE.										
FORM OWNED TO PETROBRAS N-0381 REV.L.										



TECHNICAL SPECIFICATION ^{Nº} BÚZIOS TITLE:	I-ET-3010.1M-1350-190-P4X-001	REV. 0
	SHEET 2 of 57	
	NP-2	
AND EQUIPMENT SPECIFICATION		
ESUP		

SUMMARY

1 OBJECTIVE.....	5
2 RULES AND REGULATIONS	5
2.1 IMO – International Maritime Organization	5
2.2 Brazilian Legislation and Regulation	5
2.3 Classification Society Rules	6
2.4 Petrobras Guidelines.....	6
3 DEFINITIONS	6
4 GENERAL.....	6
4.1 Collective Compartments (Rooms/Areas):	10
4.2 Service Compartments (Rooms/Areas):	10
4.3 Working Compartments (Rooms/Areas):.....	11
4.4 Privates Rooms (Cabins):	11
4.5 Sanitary Rooms:	11
4.6 Industrial Compartments (Rooms / Areas):.....	11
5 PARTITIONS, LININGS AND CEILING SYSTEM	12
5.1 General	12
5.2 Ceiling System	12
5.3 Partition and Lining System	13
5.4 Construction and Materials.....	14
5.5 Thermal Properties	15
5.6 Sound Reduction	15
5.7 Service Conditions	15
5.8 Reinforcements and Fixings.....	15
5.9 Miscellaneous Components, Trims and Finishes	15
5.10 Supply.....	16
6 “B”, “A”, “H” AND “J” CLASS DOORS	16
6.1 General	16
6.2 B-15 Rated Doors.....	18
6.3 “A” Rated Doors	19
6.4 “H” Rated Doors	19
6.5 “J” Rated Doors.....	20
7 WEATHERTIGHT DOORS	20
7.1 General	20



TECHNICAL SPECIFICATION ^{Nº} BÚZIOS TITLE: ACCOMMODATION ARCHITECTURE MATERIALS AND EQUIPMENT SPECIFICATION	I-ET-3010.1M-1350-190-P4X-001	REV. 0
	SHEET 3 of 57	
	NP-2	
ESUP		

7.2	General Requirements	20
7.3	Hinged doors.....	23
7.4	Removable panels	23
8	PASSIVE FIRE PROTECTION (PFP) AND THERMAL/ACOUSTIC INSULATION	24
8.1	Passive Fire Protection (PFP).....	24
8.2	Thermal Acoustic Insulation	27
8.3	“A” Class Bulkhead and Deck	27
8.4	“B” Class Bulkhead	28
8.5	H-120 Class Bulkhead	28
8.6	H-60 Class Bulkhead	28
8.7	H-0 Class Bulkhead	29
8.8	J-60 Class Bulkhead.....	29
8.9	J-0 Class Bulkhead	30
8.10	Delivery, Storage, Handling and Disposal	30
9	FLOOR COVERING SYSTEM.....	30
9.1	General	30
9.2	Primary Deck Covering	31
9.3	Floating floor	31
9.4	Monolithic floor	32
9.5	Anti-Acid Ceramic Tiles (H ₂ SO ₄ resistant).....	32
9.6	Elevated Floor Systems	32
9.7	Rubber Tiles or Sheet (antistatic/non-conductive type).....	34
9.8	Wooden Deck	34
9.9	FRP Grating (external use).....	35
9.10	Floor Grating (internal use).....	35
9.11	Painted Steel deck (anti-skidding)	35
10	FIRE RATED WINDOWS.....	36
10.1	General	36
10.2	Sound Characteristics.....	36
11	FURNITURE	36
11.1	General	36
11.2	IMO-testing (marine):.....	36
11.3	Furniture characteristics:.....	37
11.4	Central control room furniture and accessories:.....	39



TECHNICAL SPECIFICATION	Nº I-ET-3010.1M-1350-190-P4X-001	REV. 0		
			BÚZIOS	
			SHEET 4 of 57	
TITLE: ACCOMMODATION ARCHITECTURE MATERIALS AND EQUIPMENT SPECIFICATION		NP-2		
		ESUP		

11.5	Central Control Room benches general description:	39
11.6	C.C.R. and workstation's offices chairs:	39
11.7	Meeting room/Conference Room and workstation's guest chairs:	40
11.8	Mess Room chairs:	41
11.9	Bookcases / Cupboards:.....	41
12	TOILET UNITS (Wet units)	42
12.1	General	42
12.2	Toilet unit equipment and accessories.....	42
12.3	Industrial chemical toilet.....	43
13	SANITARY WARE AND ACCESSORIES	44
13.1	General	44
13.2	Characteristics.....	44
14	STAINLESS STEEL FURNITURE AND ACCESSORIES	45
14.1	General	45
14.2	Characteristics.....	45
15	GALLEY, MESS ROOM AND PROVISION STORE	46
15.1	General	46
15.2	Characteristics.....	46
16	INFIRMARY	47
16.1	General	47
16.2	Characteristics.....	47
17	GYMNASIUM.....	48
17.1	Gymnasium	48
18	WAREHOUSE AND STORES	48
19	WORKSHOPS AND TOOLSHOP	48
20	MISCELLANEOUS	49
21	ERGONOMIC ASPECTS.....	54
21.1	General	54
21.2	Work chairs	55
21.3	Lighting.....	55
21.4	Thermal comfort	56
21.5	Acoustic Comfort.....	56
21.6	Lifting and Transportation	56

TECHNICAL SPECIFICATION	Nº I-ET-3010.1M-1350-190-P4X-001	REV. 0		
			BÚZIOS	
			SHEET 5 of 57	
TITLE: ACCOMMODATION ARCHITECTURE MATERIALS AND EQUIPMENT SPECIFICATION		NP-2		
		ESUP		

1 OBJECTIVE

The objective of this technical specification is to present the basic requirements for the architectural works on the Accommodation Module, covering the design, construction, fabrication, assembly, inspection, testing, supply of equipment, materials and spares, all in full compliance with the provisions of this document and its attachments, all referenced applicable codes, standards and regulations and, where applicable, the Classification Society (CS) regulations.

2 RULES AND REGULATIONS

The design, construction and appliances of the Accommodation Module shall comply, but not being limited to, with the following applicable rules and regulations:

2.1 IMO – International Maritime Organization

- 2.1.1 IMO – RESOLUTION A-649 (16): Code for the Construction and Equipment of Mobile Offshore Drilling Units (MODU-CODE), 1989;
- 2.1.2 IMO – SOLAS: International Convention for the Safety of Life at Sea, 1974 and amendments in Force;
- 2.1.3 IMO – RESOLUTION MSC. 6 (48) / RESOLUTION MSC.1 (XLV): Amendments to the International Convention for the Safety of Life at Sea - 1993/ 1981;
- 2.1.4 IMO – RESOLUTION A-517 (13): Recommendation on Fire Test Procedures for A, B and F Class Division;
- 2.1.5 IMO – RESOLUTION A-472 (XII): Improved Recommendation on Test Method for Qualifying Marine Construction Materials as Non-Combustible;
- 2.1.6 IMO – MODU CODE 2009 – Chapter 09 - Protection of accommodation spaces, service spaces and control stations;
- 2.1.7 IMO – MODU CODE 2009 – Chapter 09 - Means of Escape;
- 2.1.8 IMO – MODU CODE 2009 – Chapter 09 - Portable fire extinguishers in accommodation, service and working spaces.

2.2 Brazilian Legislation and Regulation

- 2.2.1 Regulatory norms of the Brazilian ministries whenever applicable, including NR-12 (safety in machinery and equipment), NR-17 (Ergonomia/ Ergonomics) and NR-37 (Safety and Health in Oil Platforms);
- 2.2.2 Regulations of the Brazilian Maritime Authority – NORMAM/DPC – whenever applicable, including NORMAM 01 (Chapter 4, Section VII – Fire Protection Requirements for Materials and Appliances used on Board of Brazilian Ships);
- 2.2.3 ABNT Standards whenever applicable;
- 2.2.4 CONAMA Resolutions of the Environment Ministry;
- 2.2.5 NOTA TECNICA CGPEG/DILIC/IBAMA No 01/11 Projeto de Controle de poluição.



TECHNICAL SPECIFICATION	Nº	I-ET-3010.1M-1350-190-P4X-001	REV.	0
	BÚZIOS		SHEET	6 of 57
	TITLE: ACCOMMODATION ARCHITECTURE MATERIALS AND EQUIPMENT SPECIFICATION			NP-2
				ESUP

2.3 Classification Society Rules

2.3.1 ABS Guidance Notes for the Application of Ergonomics to Marine Systems.

2.4 Petrobras Guidelines

2.4.1 DR-ENGP-M-I-1.3-R.4 – Safety Engineering;

2.4.2 DR-ENGP-I-1.15-R.3 – Color Coding;

2.4.3 DR-ENGP-M-II-P1-6.1-R.6 – General Criteria for Architecture of Production Units.

3 DEFINITIONS

The following definitions shall be observed:

- Authorities: The National Shipping Inspection Bureau of the Country of Registry under whose laws and regulations the unit will be registered;
- BIDDER: It is defined as the responsible for the lift, hook up, installation and integration of all Modules on the Unit Hull;
- C.S.: The Classification Society Bureau under who's rules, regulations and survey the unit shall be certified;
- Design: The specification and complementary plans resulting from this design standard;
- ERC: Emergency Response Center.
- HULL CONTRACTOR: It is defined as the responsible for all equipment, installations and services related to conversion of Unit Hull;
- Module Supplier: It is responsible for project, assembly, erection, construction, fabrication, test and furnishing of the Module;
- OIM: Offshore Installation Manager;
- POB: People On Board; and
- UEP: Unidade Estacionária de Produção (Stationary Production Unit).

4 GENERAL

The equipment and materials supplied for Accommodation Module shall be suitable for a 25-year design life and for use in a saline atmosphere, which additionally shall be subject to weather conditions. The products shall have been successfully tested and satisfy the requirements stated in this specification, as well as C.S. rules.

Potential Module Supplier must demonstrate that they have successfully supplied equipment and materials described on this specification for use on offshore marine environment similar to that in which the unit will be installed. Module Suppliers who are interested in bidding for the above are to provide a detailed reference list demonstrating their experience, capabilities and expertise. A Module Supplier Prequalification Questionnaire must be submitted for PNBV approval, including all data pertinent to its Scope of Supply.

Module Suppliers are required to have an implemented Quality Management System that meets the requirements of the ISO-9000 series of Standards and a Safety Management



TECHNICAL SPECIFICATION	Nº	I-ET-3010.1M-1350-190-P4X-001	REV.	0
	BÚZIOS		SHEET	7 of 57
	TITLE: ACCOMMODATION ARCHITECTURE MATERIALS AND EQUIPMENT SPECIFICATION		NP-2	
		ESUP		

System. Module Suppliers shall be also notified that all work carried out on the unit Project shall comply fully with C.S. rules and Requirements or Regulations listed in this specification. Respondents must indicate company name, contact details, managers and key personnel, company profile, and summary of related experience according to the Module Supplier Prequalification Questionnaire.

All equipment and materials shall be guaranteed by the manufacturer. The equipment and materials warranty shall be clearly stated by the manufacturer during the detailed design phase proposal analysis.

The following general requirements shall be implemented during the detailed design phase:

- The material finishing weight shall be updated during design phase in accordance with manufacturer information's;
- All components shall be adequate to offshore humidity and corrosive environment with marine salts and hydrocarbons;
- Partition, lining and ceiling system, doors/ windows, floor covering system and insulation shall be provided with the characteristics stated on this specification. Equivalent material may be accepted provided the physical, chemical and mechanical characteristics are preserved. Any deviation of the requirements stated on this specification shall be submitted during Technical proposal Analysis phase (detailing) in order to be analyzed and approved by PNBV;

All insulation materials, linings, ceilings, floors, upholstery materials, windows and doors as well, shall be specified in accordance with applicable rules and regulations. All the listed material shall be non-combustible / fire-retardant type. The use of combustible materials, such as acrylic, polycarbonates, PVC, and others, is not allowed;

- Fire rated doors, removable panels and windows shall be certified to have the same fire rating as the wall they are installed on;
- Doors and removable panel dimensions shall allow for the transit of people, stretchers, equipment parts, etc., and shall not impose an obstacle for any of these activities;
- Compartments with areas exceeding 20 m², normally uninhabited or that present risks for users, like compartments protected by the CO₂ System, shall have two exits;
- Cabin fan coil units (if specified), shall be installed in a specific ceiling recess between the ceiling panel and the steel deck above. The drain shall be detailed and installed in order to avoid any leakages. The drain itself shall not be exposed but properly covered and kept out of sight;
- Wall and ceiling panels shall be provided with access hatches and/or access doors. These accesses shall be located during the detailed design phase according to maintenance needs and requirements. The detail design phase shall present a drawing with the detail and location of these hatches;
- In accommodation, the free height shall be at least, 2400;
- The free width in corridors shall be at least 1200 mm;



TECHNICAL SPECIFICATION	Nº	I-ET-3010.1M-1350-190-P4X-001	REV.	0
BÚZIOS			SHEET	8 of 57
TITLE: ACCOMMODATION ARCHITECTURE MATERIALS AND EQUIPMENT SPECIFICATION			NP-2	
			ESUP	

- All Windows shall have decorative and blackout curtains and all berths shall be provided with blackout curtains, which shall remain non-flammable or flame retardant after cleaning, and shall be pre-shrunk. Curtains shall allow repeated washing;
- All necessary accessories and materials for the installation of curtains shall be provided allowing its fixation in open and closed position;
- In partition walls, doors and furniture, all glass made visors and windows shall be composed of laminated glass, so the material do not produce splinter whenever subjected to impact or explosion;
- Background music shall be provided for all compartments, with control from Central Control Room and local volume control;
- One key cutting machine shall be supplied onboard for duplication of lost keys. This machine shall be supplied by the doors manufacturer, together with the doors and relative keys. Location of machine will be defined by PNBV in the detailed design phase;
- A visual communication/information design (including safety signs) shall be carried out during the detail design phase in order to guarantee the easy location of all compartments by its users as well as a pleasing and safe ambient. PNBV shall be consulted in order to provide all information regarding PNBV standard signalization to be followed;
- All equipment and Furniture shall have commercial representation in Brazil, in order to guarantee maintenance or replacement if needed;
- The handrails of internal staircases and corridors shall be constructed in stainless steel. Location shall be in accordance with layout drawings;
- The maximum accepted angle for access stairways shall be 38°. During the detail design phase, the Supplier shall find the ways to design the inclined stairs as present in the Basic Design drawings;
- Fire hydrants and extinguishers shall be inlaid in the bulkheads when installed in environment internally coated. Installation shall follow the applicable rules;
- A ring main for high-pressure wash down stations shall be considered in areas where heavy cleaning will take place;
- The overall and local cargo capacities shall be painted on the floor and lower guard-rail stop. The areas for the transfer of cargo will be lined with wooden planks for industrial use;
- The internal layout of the compartments must have enough flexibility in order to allow adjustments required by work activities;
- The internal layout design shall be executed individually on a scale of 1:50 or 1:25 if possible, including at least 2 (two) sections and any other view required for complete clarification of the space. These drawings shall contain main dimensions, furniture location, pictures and any other object;
- Compartments location and area shall be indicated in the arrangement drawings. The layout showing all furniture and equipment, as well as its quantity must be entered into architecture arrangements;



TECHNICAL SPECIFICATION	Nº	I-ET-3010.1M-1350-190-P4X-001	REV.	0
	BÚZIOS		SHEET	9 of 57
	TITLE: ACCOMMODATION ARCHITECTURE MATERIALS AND EQUIPMENT SPECIFICATION			NP-2
				ESUP

- At least, two colors per material shall be submitted to PNBV approval, to define the Decoration Scheme, including catalogs containing specification colors and characteristics of all materials, besides the typical arrangement. If the Module has more than one deck, variety of colors per deck shall be presented, since the use of different colors for covering materials per deck makes easier their identification;
- All materials and components supplied shall be new, delivered clean and in proper use conditions and of quality compatible with the requirements in this document;
- All materials, before and after installation, shall be protected against damage of any kind (abrasion, dirt, oxidation, etc.);
- For Ergonomic requirements, refer to document I-ET-3010.1M-1350-196-P4X-002 – ERGONOMIC REQUIREMENTS FOR HULL;
- The noise of the accommodations shall be in accordance with I-ET-3010.1M-1200-300-P4X-002 – NOISE CONTROL REQUIREMENTS FOR ACCOMMODATION. Items like insulation material, wall and ceiling panels, doors, windows and floor covering shall be provided in order to comply with noise and vibration analysis report developed in the detailed design phase;
- Paints, varnishes and other finishes used on exposed interior surfaces shall be in accordance with regulations and C.S. rules and shall not be capable of producing excessive quantities of smoke or offer an undue fire hazard;
- Compartments affected by structure borne noise shall be isolated considering the following:
 - o Decks shall be protected making use of a primary deck (if floor finishing is required), combined with vibration damping material and steel tiles 1.5 to 2.0 mm thickness. In this case, the floor covering shall be a sandwich construction;
 - o Bulkheads shall be protected by a combination wall, for vibration damping and sound reduction, making use of a vibration damping material and steel tiles 1.5 to 2.0 mm thickness. When applicable, a wall panel shall be installed.
- For details, see documents:
 - o I-DE-3010.1M-1350-190-P4X-001 – MAIN DECK ACCOMMODATION LAYOUT;
 - o I-DE-3010.1M-1350-190-P4X-002 – A DECK ACCOMMODATION LAYOUT;
 - o I-DE-3010.1M-1350-190-P4X-003 – B DECK ACCOMMODATION LAYOUT;
 - o I-DE-3010.1M-1350-190-P4X-004 – C DECK ACCOMMODATION LAYOUT;
 - o I-DE-3010.1M-1350-190-P4X-005 – D DECK ACCOMMODATION LAYOUT;
 - o I-DE-3010.1M-1350-190-P4X-006 – E DECK ACCOMMODATION LAYOUT;
 - o I-DE-3010.1M-1350-190-P4X-007 – F DECK ACCOMMODATION LAYOUT;
 - o I-DE-3010.1M-1350-190-P4X-008 – TOP ROOF AND HELIDECK PLAN;
 - o I-DE-3010.1M-1350-190-P4X-014 – ACCOMMODATION SECTIONS; and
 - o I-DE-3010.1M-1350-190-P4X-015 – ACCOMMODATION ELEVATIONS.

TECHNICAL SPECIFICATION	Nº I-ET-3010.1M-1350-190-P4X-001	REV. 0		
			BÚZIOS	
			SHEET 10 of 57	
TITLE: ACCOMMODATION ARCHITECTURE MATERIALS AND EQUIPMENT SPECIFICATION		NP-2		
		ESUP		

- The structure borne vibrations shall be transformed from kinetic energy into heat by the deformation in the damping layer. The damping layer consists of a polyurethane compound of 1.0 to 1.5 mm thickness and shall be low-flame spread.
- The detailed design shall follow the noise prediction study and provide, if required, the insulation and all components in accordance with regulations and C.S. rules.
- The following definitions shall be observed during the detailed design phase regarding compartments characteristics:

4.1 Collective Compartments (Rooms/Areas):

Are those compartments/areas where several people stay for recreation purpose or for work journey breaks:

- Mess Room;
- Coffee Points;
- Gymnasium and Gym free floor area;
- Multi-purpose/ Music Room;
- Quiet Recreation Room;
- TV Video Lounge;
- Internet Room;
- Games Room;
- Reception/ Briefing;
- Auditorium;
- And others areas or compartments considered as collective compartments.

4.2 Service Compartments (Rooms/Areas):

Are those compartments where several services are carried out to guarantee the operation, maintenance of the unit and assistance of its users:

- Treatment Room/ Infirmary/ Clinic and Waiting Room;
- Galley (all compartments);
- Barbecue Area/ Varanda;
- Provision Stores (Including existing Cold Storage);
- Garbage Area;
- Water Gallon Area (news and used);
- Workshops: Mechanical, Electrical, Instrumentation, Welding, PSV and Painting;
- Laundries;
- Janitor and Cleaning Material Stores;
- Linen Room;
- And others areas or compartments considered as service compartments.

4.3 Working Compartments (Rooms/Areas):

Are those compartments where working activities are carried out to maintain the unit production and operation. In the Accommodation Module, there are working rooms in almost all decks.

- Geplat (OIM) Office;
- Main Offices, 1 and 2;
- Coordination Office;
- Camp Boss and Catering Office, with Kiosk;
- Other offices: Inspector and PH, MIEE and MIED, Visitor, TLT, SUMEC & SUEIN, Warehouse, PSV, etc.;
- Meeting Room / Video Conference (the two of that);
- C.C.R (Operation Ambiance, Equipment Ambiance and Automation & TBM Room);
- Telecom CCR Room and Telecom Panels Room;
- Radio Room;
- Technical Library;
- And others areas or compartments considered as Working Compartments.

4.4 Privates Rooms (Cabins):

All rooms used as living quarters by a crew member. All cabins shall have private toilet unit. Refer to item 10.0 (Furniture).

4.5 Sanitary Rooms:

Restrooms (w.c.) shall be distributed for men and women in all Accommodation Decks:

- Restrooms;
- Private Toilet Units; and
- Changing Rooms.

4.6 Industrial Compartments (Rooms / Areas):

Compartments inside Accommodations Module such as below:

- Deck Stores (except accommodation stores);
- Warehouse;
- Tool shop;
- HVAC Rooms;
- Batteries Rooms;
- Telecom Panels Room;
- Paint Store;



TECHNICAL SPECIFICATION	Nº	I-ET-3010.1M-1350-190-P4X-001	REV.	0
	BÚZIOS		SHEET	12 of 57
	TITLE: ACCOMMODATION ARCHITECTURE MATERIALS AND EQUIPMENT SPECIFICATION			NP-2
				ESUP

- Emergency Response Base Room;
- Emergency Diesel Generator;
- CO2 Cylinder Room;
- Normal Transformers Room;
- Normal Panels Rooms;
- And others areas or compartments considered as industrial area/room.

The design shall provide all equipment location taking into account the easy access to all parts for operation and maintenance. Cargo handling shall be provided whenever required and shall be detailed in such way that provides all facilities for entrance and exit of the equipment without disturbing the work activity in accordance with general arrangement drawings, document I-ET- 3010.1M-5266-630-P4X-002 - HULL/ACCOMODATION HANDLING PROCEDURES and the ergonomic aspects, presented in the document I-ET-3010.1M-1350-196-P4X-002 – ERGONOMIC REQUIREMENTS FOR HULL.

5 PARTITIONS, LININGS AND CEILING SYSTEM

5.1 General

- 5.1.1 All materials, components and fittings, used in construction shall be "non-combustible" type and follow current regulations. Material and finishes to components and fittings used in partitions, linings and ceiling panels shall be non-flammable, shall not be able to emit flame and shall have certified low surface spread of flame characteristics in accordance with current rulings.
- 5.1.2 Manufacturer instructions shall prevail regarding partitions requirements design and installation, unless otherwise specified.
- 5.1.3 Wall panel system shall be installed under the in site supervision of the manufacturer(s).

5.2 Ceiling System

- 5.2.1 The ceiling panels shall be built with a flat face and constructed with galvanized steel sheet 0,5 mm thick (minimum). Halogen free material finishing shall be provided for all compartments. The ceiling panels shall have steel on both sides and be capable to hold required ventilation devices without support.
- 5.2.2 The ceiling system shall be self-supporting, capable to bear the weight of 25 kg load without suspension, with an inter-locking joint and easily dismantled for maintenance purposes.
- 5.2.3 The ceiling panels shall be supported by the wall panel top profiles. Approved hinged access ceiling lights shall be provided to ensure the B-15 rating and full compatibility. Services shall be installed between ceiling panel and steel deck and shall not be supported by any part of the ceiling system.
- 5.2.4 Hinged inspection panels, which combine with the surrounding ceiling panels, shall be provided where inspection and maintenance to installed services above the ceiling is required. The clear opening shall be minimum 500 x 500 mm.



TECHNICAL SPECIFICATION	Nº	I-ET-3010.1M-1350-190-P4X-001	REV.	0
	BÚZIOS		SHEET	13 of 57
	TITLE: ACCOMMODATION ARCHITECTURE MATERIALS AND EQUIPMENT SPECIFICATION		NP-2	
		ESUP		

- 5.2.5 The hatch construction shall be strong enough to allow for repeated opening. Unless the hatch has a fail-safe opening mechanism, a safety chain shall be included to avoid accidental opening.
- 5.2.6 Insulation around ceiling penetration (e.g., lighting fixtures, diffusers, sprinklers, ducting, etc.) shall maintain the overall integrity of the ceiling fire rating. The complete ceiling shall in every respect be compatible with the wall system.
- 5.2.7 The ceiling panels system shall be B-15 class recognized by C.S. Extra insulation shall not be installed above the ceiling panels in order to achieve the B class fire rating. The mineral wool used shall be non-combustible and free of asbestos. Minimum density shall be in accordance with manufacturer's standard and suitable regarding noise aspects.
- 5.2.8 The ceiling panels shall be available with the following characteristics:
 - Width about 600 mm, Thickness 50 mm, length of ceiling panel max. 3000 mm free span, B-15 fire class, weight about 18 kg/m².
- 5.2.9 Special tools required for ceiling panels' installation and maintenance shall be provided whenever this material is installed.

5.3 Partition and Lining System

- 5.3.1 The partition and lining systems shall be fully compatible with all installations, elements, fixtures, fittings and penetrations, as well as all requirements to stability, sound reduction and fire class. The system shall be chemical resistant, halogen-free, low flame spread surface, low calorific value, no chlorides, no cyanides and no dioxin.
- 5.3.2 Partition and lining panel colors shall be in accordance with the color schedule. At least, two colors per deck shall be available. Even if there is only one deck, at least two colors per material shall be submitted to PNBV approval, to define the Decoration Scheme that shall be submitted to PNBV approval, including catalogs containing specifications colors, and characteristics of all materials.
- 5.3.3 Partitions in wet rooms shall be completely splash-proof, non-combustible and easy to maintain and clean.
- 5.3.4 The internal glazed partition system shall consist of a series of fire rated glazed or solid panels, which are supported by framing members. Partitions of the same fire rating, wherever possible, shall have the same thickness, regardless of span. The system shall be finished complete with all insulation, make-up pieces and cover plates of the same material and finishes as the glazed partition system. Glazing shall be laminated security glass. Glazed partition shall be built up by a framework of stainless steel profiles covered with insulation. The profiles shall be fixed to the framework as a "clip on" solution with no visible bolts or blind rivets. The glass type shall be clear transparent fire resistant with intumescent interlayer and sound reduction: field value of ≥ 41 dB, B class, at least 30 mm thick. Maximum glass size shall be in accordance with manufacturer standard. Glazed partition shall be replaced by glass window if previously agreed with PNBV.
- 5.3.5 Where mineral wool insulation is used, it shall be non-combustible, and fully bonded to the rear of the galvanized panels. Steel sheets used for panel faces shall be galvanized on both sides prior to construction of the complete panel.



TECHNICAL SPECIFICATION	Nº I-ET-3010.1M-1350-190-P4X-001	REV. 0
BÚZIOS		SHEET 14 of 57
TITLE: ACCOMMODATION ARCHITECTURE MATERIALS AND EQUIPMENT SPECIFICATION		NP-2
		ESUP

- 5.3.6 Partition and lining panels shall be available with a width about 600 mm.
- 5.3.7 The wall system, unless otherwise specified, shall not exceed a maximum of 75 mm in overall thickness, including the thickness of applied finishes (Refer to item 4.4).

5.4 Construction and Materials

- 5.4.1 The partition system shall be modular system, sandwich construction steel faced with a flush surface finishing. The system shall be capable to suppress services and each panel must be fully dismantable for maintenance or replacement purposes.
- 5.4.2 The standard panel system shall include special jointing profiles that allow panels already installed to be removed. The detachable panel construction should be used only for occasional access. For frequent access the inspection door shall be installed.
- 5.4.3 The panel system should be assembled by the use of jointing "H" profiles in order to assure the wire and cables passage and also to provide a quick access when replacing the panels.
- 5.4.4 Self-supporting ceilings shall be fire tested with the ceiling panels fixed to the top profiles on the wall panels with screws or pop rivets.
- 5.4.5 The lining system shall have the same characteristics of the partition. The joints between partitions and ceiling panels as well partitions and linings shall be detailed in order to avoid loss of performance regarding sound and vibration transmission.
- 5.4.6 The wall installation may possibly use gaskets between steel coaming and wall panel in order to minimize the effects of noise vibration.
- 5.4.7 The partition/lining system shall satisfy the requirements relating to noise, thermal and fire characteristics. The system used shall be so designed, constructed and installed to provide internal walls of certified B-15 fire rating in accordance with SOLAS regulations and amendments.
- 5.4.8 The partitioning system shall consist of:
- 5.4.9 Partition: Wall panels' thickness shall be 50 mm with 45 dB noise reduction minimum. The finishing shall be halogen free surface type and impressed directly into the galvanized steel sheet on both sides.
- 5.4.10 Lining: Lining panels' thickness shall be 50 mm with 45 dB noise reduction minimum. The finishing shall be halogen free surface type and impressed directly into the galvanized steel sheet on one side and the other side with galvanized steel finishing.
- 5.4.11 Ceiling: Self-supporting system with halogen free surface material finishing, impressed directly into the steel sheet, 50 mm thickness. Noise reduction of RW=45 dB, NRC 0.60 (minimum).
- 5.4.12 Note: Lining panels with 32 dB sound reduction shall be used provided that they are suitable regarding noise aspects.



TECHNICAL SPECIFICATION	Nº	I-ET-3010.1M-1350-190-P4X-001	REV.	0
	BÚZIOS		SHEET	15 of 57
	TITLE: ACCOMMODATION ARCHITECTURE MATERIALS AND EQUIPMENT SPECIFICATION		NP-2	
		ESUP		

- 5.4.13 All material construction shall be provided in order to comply with noise and vibration analysis report developed.
- 5.4.14 In all cases, ease of removability of any panel with minimal disturbance to adjacent panels shall be assured.
- 5.4.15 Wall panel system colors shall be in accordance with the color scheme for Accommodation, to be submitted to PNBV approval.
- 5.4.16 Partitions in wet rooms shall be completely splash-proof and easy to maintain and clean.

5.5 Thermal Properties

- 5.5.1 The thermal insulation factor achieved by the wall panels shall be according to I-ET-3010.1M-5250-300-P4X-001 - HVAC SYSTEM DESIGN.

5.6 Sound Reduction

- 5.6.1 The installed system shall be capable of providing a verified sound reduction in accordance with item 4.4 for any other compartment where wall and ceiling panels are required and shall be confirmed with noise and vibration analysis report developed in the detailed design phase.
- 5.6.2 All material construction shall be provided in order to comply with noise and vibration analysis report.
- 5.6.3 The detailed design phase shall verify if the partition, lining and ceiling system stated in this specification is suitable to provide the required noise results for inhabited compartments located in Industrial Area. If the noise values do not achieve the required values, the system shall be integrated regarding insulation (structural and airborne damping material and floating floor), floor covering system and lining/partition system in order to comply with the requirements stated in I-ET-3010.1M-1200-300-P4X-002 – NOISE CONTROL REQUIREMENTS FOR ACCOMMODATION.

5.7 Service Conditions

- 5.7.1 The partitioning system shall be suitable for use in fully air-conditioned environment.

5.8 Reinforcements and Fixings

- 5.8.1 Wall-mounted equipment shall always be within the manufacturer's specified maximum capacity for the partition system. Wall-mounted equipment shall be directly supported by the main frame or the structure supporting the wall panels.
- 5.8.2 Fixings and reinforcements shall enable future removal and re-fixing of equipment. All reinforcements shall be concealed within the wall panels.
- 5.8.3 Irrespective of the weights of small fittings and fixtures which are to be wall mounted, panels shall be provided with suitable solid fixed backings, fully concealed within the wall construction, to accept fixings in order to ensure easy replacement of fittings after removal.

5.9 Miscellaneous Components, Trims and Finishes



TECHNICAL SPECIFICATION	Nº	I-ET-3010.1M-1350-190-P4X-001	REV.	0
BÚZIOS			SHEET	16 of 57
TITLE: ACCOMMODATION ARCHITECTURE MATERIALS AND EQUIPMENT SPECIFICATION			NP-2	
			ESUP	

- 5.9.1 All profiles, panels, trims, joints, standard and support profiles shall be supplied to ensure a complete installation.
- 5.9.2 As far as possible, frames, panels, trims, joints, standard and support profiles shall be supplied in available standard sizes and lengths. The joints of the system shall be installed in order to minimize sound conduction. The design and installation of the wall shall use standard components to the greatest extent possible, with due regard to visual appearance and functional durability. The Module Suppliers shall provide suitable heavy-duty skirting and trimmings for all wall bases and joints. All panels shall be supplied with factory applied finishing.

5.10 Supply

- 5.10.1 The wall and ceiling panels shall be supplied with easily removable protective foil, sufficient to protect finishing during storage, handling, construction and commissioning.
- 5.10.2 All panels incorporating special items or panels designed for particular application shall be supplied clearly marked.

6 “B”, “A”, “H” AND “J” CLASS DOORS

6.1 General

- 6.1.1 The “B”, “A”, “H” and “J” rated doors shall be fully compatible with the proprietary partition systems. “J”, “H”, “A” and “B” class doors shall be fully tested and certified as “J”, “H”, “A” or “B” doors in accordance with international applicable requirements and criteria. “A” rated doors shall be fitted with permanently attached means of self-closing. Holdback catches or hooks shall be provided to all “B” class doors.
- 6.1.2 Doors Sound absorption shall be a minimum of 39 dB (ventilation grille not included). All doors shall have suitable Doors Sound Absorption in order to comply with noise and vibration analysis report developed in the detailed design phase.
- 6.1.3 Doors, with associated hardware shall be designed and arranged according to ergonomic principles so that the potential for injury to persons is reduced. Door assemblies shall be easily operable in a hazardous or accidental situation.
- 6.1.4 Panic bars shall be provided on doors in areas where there is a risk of congestion or panic. At least, all internal doors located in Escape routes and Muster stations shall have panic bars.
- 6.1.5 Doors located in Escape routes shall not be fitted with locking devices.
- 6.1.6 Kick plates (300 mm height) and trolley protection plates (800 mm height) in brushed stainless steel shall be provided for hinged doors in traffic areas to protect the doors from passage of workers that need to pass through the doors using carts and to prevent damage to the doors that may be caused with the passage of workers using trolleys.
- 6.1.7 Kick plates and trolley protection plates shall be mechanically fixed with flush fixings. There shall be no sharp or protruding edges.



TECHNICAL SPECIFICATION	Nº	I-ET-3010.1M-1350-190-P4X-001	REV.	0
BÚZIOS			SHEET	17 of 57
TITLE: ACCOMMODATION ARCHITECTURE MATERIALS AND EQUIPMENT SPECIFICATION			NP-2	
			ESUP	

- 6.1.8 Threshold detailing and door arrangement shall stop all ingress of water from decks.
- 6.1.9 A preliminary schedule with doors' characteristics (class, dimensions, accessories etc) shall be developed as part of the basic design phase. It shall be continuously updated throughout the various project phases, until all required information is specified prior to procurement of the doors.
- 6.1.10 "A" class doors shall be gastight in compartments provided with CO₂ system, where there is a differential pressure. These doors shall open outwards and shall be provided with hydraulic door closer. Leakage rate shall not exceed 0.5m³/m²h at 50 Pa over pressure following prolonged use, or specified by the project. The test certificate shall be provided with each door type. If there is any divergence between the basic arrangement drawing and C.S. Rules, C.S. rules shall prevail.
- 6.1.11 "A" rated doors shall be fully tested and certified in accordance with the Classification Society requirements. All required thresholds shall be dimensionally as low possible, without impairing function with regards to fire rating, noise reduction, and ability to stop ingress of water.
- 6.1.12 Doors through which regular passage of trolleys must be allowed shall have the thresholds so arranged as to provide an absolute minimum of obstructions. This may be achieved by the use of thresholds with integral ramps, or by using deck leveling screeds and associated floor finishes creating local ramps to compensate threshold heights.
- 6.1.13 All door leaves shall be fully insulated without any air pockets. Insulation fibers shall be sealed to prevent any fibers from being released to the environment.
- 6.1.14 Hinged doors with 2500 mm high (or more), shall be provided with four hinges, minimum. Doors with height up to 2500 mm shall be supplied with three stainless steel hinges, closers, latches, lever handles and locks, if specified. Lever handles shall be of ergonomic shape to prevent fouling of clothing. All hardware, hinges, locks and other fittings shall be stainless steel. Hinges shall be heavy-duty lift off butt or equal approved, to permit removal of the door leaf. Latches shall be spring mortise type, keyed or unkeyed. Door handles shall be solid with a minimum 9 mm spindle. Lock screws in spindles shall be of a type that does not need periodical re-tightening.
- 6.1.15 Door frames shall be installed, as appropriate, by either bolting through air tight isolation gaskets, or by a continuous fillet weld all round. Frames shall be reinforced at hinges, locks and closer device positions. Detailing shall minimize galvanic corrosion.
- 6.1.16 All doors shall be supplied with 2 (two) keys. The system door shall be provided with 3 (three) master keys. The doors located on corridors, escape routes and staircases shall not be fitted with lockers, other doors shall be fitted with lockers unless otherwise specified. Vision panels shall be an integral part of the certified door. The glazed area shall be approximately 200 x 400 mm (W x H). The vision panels shall not impair the function of the sliding door sealing.
- 6.1.17 The doors between compartments with and without air-conditioning shall be provided with thermal insulation.



TECHNICAL SPECIFICATION	Nº I-ET-3010.1M-1350-190-P4X-001	REV. 0
BÚZIOS		SHEET 18 of 57
TITLE: ACCOMMODATION ARCHITECTURE MATERIALS AND EQUIPMENT SPECIFICATION		NP-2
		ESUP

- 6.1.18 Door stops of chrome plated brass with rubber head and catches shall be installed for all offices doors. Door stops shall be resilient, easily removable and shall be positioned so as not to present a tripping hazard especially to escaping personnel.
- 6.1.19 All hinged fire doors, stairway doors and doors of closed spaces leading outside shall be provided with an overhead heavy-duty hydraulic door closer. Door closers shall not obstruct the action of the doors or reduce the specified clear openings. Door closers shall not incorporate a stay open device. The frames and door leafs for all doors shall be delivered with pre-drilled holes for fixing of door closers. Suitable reinforcements shall be provided within the doors and doorframes.
- 6.1.20 Door leaves shall be properly reinforced at hinges, locks, handles, closer devices and any other places where hardware is to be attached to the door.
- 6.1.21 Doors shall be marked with stainless steel nameplate with engraved lettering colored with enamel paint. The nameplate shall be affixed 1600 mm above the floor. The nameplate shall identify the Room Number (to be assigned) and the Room Name (to be confirmed). Name plates shall be in Portuguese and English language.
- 6.1.22 All doors and frames shall have applied finishing compatible with the partition wall. B-15 door thresholds shall be made of 1 mm stainless steel and shall be flush with finished floor's level, except for wet areas. Stainless steel door leaf, door frame and hardware shall have the surface protected by plastic film during shipment and construction at the yard. Carbon steel scratching and grinding sparks must not contaminate any of the stainless steel surfaces. Damaged surfaces shall be chemically removed and then refinished to a bare bright surface. Door frames shall be factory finished, standard painting (Munsell or RAL) scale, and the fixing of door hardware shall be such as not to damage any applied finishes. Door leaf surfaces shall be halogen free finishing.
- 6.1.23 Threshold shall be provided at wet areas. The surface shall be finished with a homogeneous skirting board with round corner. Doors shall be placed in position after the installation of wall panels. Door closers, latches and other items shall be fully adjusted and tested for proper action, and all access panels or other removable panels shall be adjusted and operated as necessary to ensure their proper performance.

6.2 B-15 Rated Doors

6.2.1 Construction and Materials

The construction of B-15 rated doors shall be as follows, unless otherwise specified:

Frames - Galvanized steel profile frames to interlock with partition wall openings, incorporating over panels in the transom where necessary. Frames shall be supplied to fit all types of bulkheads and installation methods.

Leaves - Sandwich construction, stiffened flush framed panels with facings on both sides in halogen free material surface finishing, coated galvanized steel



TECHNICAL SPECIFICATION	Nº	I-ET-3010.1M-1350-190-P4X-001	REV.	0
	BÚZIOS		SHEET	19 of 57
	TITLE: ACCOMMODATION ARCHITECTURE MATERIALS AND EQUIPMENT SPECIFICATION			NP-2
				ESUP

sheets, incorporating a fully bonded core of non-combustible mineral wool insulation, and free of asbestos.

Concealed solid fixed backings shall be provided within the leaf thickness for door hardware fixing. Sound reduction value shall be compatible with the installed wall system in which the door is installed.

The door frame shall be provided with a resilient pad on three meeting faces to reduce the impact noise caused by the closing action of the door.

6.3 “A” Rated Doors

6.3.1 Construction and Materials

Concealed solid fixed backings shall be provided within the leaf thickness for fixing of door accessories. “A” class doors shall be provided with gaskets. Gasket seals shall maintain the specified integrity of the door throughout the door’s specified life time. Gaskets shall be glued or mechanically fixed in such a way that they may be easily replaced. Gaskets shall maintain the elasticity and allow for lathing and full perimeter sealing of door-leaves during continuous heavy use, without requiring excessive force or slamming. Gaskets in zone 1 classified areas doors and doors which shall maintain differential air pressure shall be selected and arranged in order to guarantee the long term sealing performance requirements. “A” class door leaf shall be made of steel plate with mineral wool core, frame made of galvanized steel profile, 3-part hinges with ball bearing and grease nipples, reinforcement for door closer, magnet and cut out for lock.

Frames - Galvanized profile steel frames to interlock with partition wall openings, incorporating over panels in the transom where necessary. Frames shall be supplied to fit all types of bulkheads and installation methods.

Leaves - Sandwich construction, stiffened flush framed panels with facings on both sides halogen free material finishing, coated galvanized steel sheets, incorporating a fully bonded core of non-combustible mineral wool insulation, and free of asbestos.

Sound insulation value shall be compatible with the installed wall system in which the door is installed.

6.4 “H” Rated Doors

6.4.1 Construction and Materials

“H” class doors shall be fully tested and certified as “H” doors in accordance with international applicable requirements and criteria. “H” rated doors shall be fitted with permanently attached means of self-closing. The “H” class doors leaf shall be stainless steel finishing 2 mm thickness and door frame 4 mm thickness.

External hinged “H” rated doors shall be suitable for offshore constructions as protection against hydrocarbon fires and explosions. The door leaf shall have reinforcement plates for hinges and door closer. The door frame shall be constructed with a profile shaped to give maximum tightness, with 3 separate areas of impact.

The frame shall be proper for bolting or welding. The hinges shall be stainless steel, bolted to the door leaf and welded to the door frame and shall be provided



TECHNICAL SPECIFICATION	Nº	I-ET-3010.1M-1350-190-P4X-001	REV.	0
	BÚZIOS		SHEET	20 of 57
	TITLE: ACCOMMODATION ARCHITECTURE MATERIALS AND EQUIPMENT SPECIFICATION		NP-2	
		ESUP		

with washers between the top and bottom parts to reduce friction. Air and gas tightness shall be at least 0.4m³/hm² at 50 Pa, or in accordance with design directives. Lock-case shall be operated with one center mounted handle. Sound insulation value shall be compatible with the installed wall system in which the door is installed.

6.5 “J” Rated Doors

6.5.1 5.3.1 Construction and Materials

HOLD

7 WEATHERTIGHT DOORS

7.1 General

- 7.1.1 A closing appliance is said to be weathertight if it is capable, under any sea conditions, of preventing the penetration of water into the unit. Doors exposed to the weather and strong winds shall be robust stainless steel sliding or hinged doors. The door leaf shall be a sealed unit, totally impervious to moisture. Sliding doors shall be mounted on the outside of the walls.
- 7.1.2 All weathertight doors shall withstand the extreme environmental design conditions on the field location. Detailing shall prevent any water on external decks from passing through the door construction. Doors shall be of stainless steel plate, type AISI 316L, or alternatively AISI 316 with a maximum carbon content of 0.05 % and installed to avoid moisture condensation and to dampen the external noise.
- 7.1.3 Weathertight doors shall be installed according to the basic design as well Classification Society rules and applicable regulations. Certificates type examination (type approval certificate) shall be provided during proposal analysis phase. If there is any inconsistency between the Doors Arrangement and C.S. rules, C.S. rules shall prevail.
- 7.1.4 All external doors shall be at least “A-0” class as per required by item 9.2.9 of MODU Code. These doors shall be installed in order to avoid any gas leakage and shall be, as previously required, completely sealed. Weathertight doors for rooms equipped with CO₂ firefighting system shall be supplied with limit switch (REED RELAY TYPE).
- 7.1.5 Doors or hatches within weathertight bulkheads shall be certified to meet the applicable design pressures (see applicable maritime requirements). Quick-acting doors shall be those designed to effect simultaneous closing or opening action by the operation of a single lever or hand wheel.
- 7.1.6 Weathertight doors’ dimensions and sills shall be confirmed during the detailed design phase, considering their use and location, also dimensions of equipment that may be transferred between compartments and outside.

7.2 General Requirements

7.2.1 Tightness



TECHNICAL SPECIFICATION	Nº I-ET-3010.1M-1350-190-P4X-001	REV. 0
BÚZIOS		SHEET 21 of 57
TITLE: ACCOMMODATION ARCHITECTURE MATERIALS AND EQUIPMENT SPECIFICATION		NP-2
		ESUP

Where weather-tightness is required, weather-tight seals shall be added. The weather tightness shall be verified by hose testing from the outside after installation. No leakage shall be accepted. On floating production units and semi-submersibles, weathertight doors may be required on or above freeboard decks. In addition to the sealing requirement stated above, these doors shall be designed for a strength equivalent to or better than that required for the weather-tightness of the structure in which they are positioned.

Weathertight closing appliances are required for those external openings being submerged at least up to an angle of heel equal to the dynamic angle. This applies to any opening within 4.0m above the final waterline as well. Doors shall generally open outwards to provide additional security against impact of the sea.

Doorsill heights shall be from steel deck to clear opening door and shall be defined in accordance with ILLC (MSC 77/26/Add.1, ANNEX 3), as described on item 3.7 of MODU Code or applicable rule regarding F.P.S.O. or semi-submersible platform.

7.2.2 Opening Pressure

The opening force required to open a door, as measured with a dynamometer or similar device, shall not exceed the following limits for doors in frequent use, (major traffic, escape route doors or doors used more than 10 times a day), when these doors are in a level position:

- Hinged doors: 65 N
- Sliding Doors: 50 N

For all other doors the following limits shall not be exceeded:

- Hinged doors: 130 N
- Sliding Doors: 105 N

The maximum acceptable opening force in accidental situation shall never exceed 250 N, for doors defined as escape doors. Hinged doors leading to open areas shall be provided with a damping mechanism to prevent injuries.

7.2.3 Design

Means shall be provided to prevent closures from rattling. Locking devices shall be provided on all closures giving access to spaces or areas required to be locked. All hinged doors in emergency exits shall open outwards in the direction of the escape route and shall be easily opened from both sides by one person.

Padlocks shall be supplied for all external doors whose closing systems do not allow installation of lockers with keys. All "A" class hinged doors and emergency escape doors shall have self-closing device.

Door frames shall be installed, as appropriate, by a continuous fillet weld all around. To reduce transmission of forces from bulkhead into doorframe, which may affect proper alignment and operation of door, maximum plate buckling at perimeter of cutout shall be 5 mm along straightedge.

Any additional components, which are required to comply with fire rating, such as, exposed frame insulation covering and associated flashing, shall be provided. For a complete delivery, gaskets, screws and screw cover must be included.



TECHNICAL SPECIFICATION	Nº I-ET-3010.1M-1350-190-P4X-001	REV. 0
BÚZIOS		SHEET 22 of 57
TITLE: ACCOMMODATION ARCHITECTURE MATERIALS AND EQUIPMENT SPECIFICATION		NP-2
		ESUP

All emergency doors shall be painted (internal side) with color Munsell 5R 4/14 according to NR-26. PNBV shall be consulted regarding location of these doors.

All doors and their respective frames and coamings, shall be designed and constructed to be as light as practicable, consistent with necessary strength, duty, tightness, rigidity requirements, and fire-retardant characteristics. They shall withstand, without permanent distortion, the specified proof test pressures, when applied to both sides (not simultaneously).

The rigidity of all closures shall be such as to prevent limberness, to maintain the gasket (or contact) surface in a single plane under normal service conditions, to prevent distortion and to seat the gasket. Opening devices for doors shall be sufficiently offset and be so located as to prevent injury to the hands of operating personnel. The handles finish shall be smooth, without flash or projections. All operating and securing devices for doors shall be so designed and constructed that they cannot be released by vibration. On quick-acting doors, the operating opening device shall be designed to cause no obstruction of the passage opening when the door is in the open condition. When hinged doors are designed to seat gaskets tightly around their entire periphery (by securing devices), the hinges shall be designed to prevent binding and damage to the hinges or closures in the tightening process.

Doors in structural bulkheads shall have rounded corners. Door frames in structural bulkheads shall be reinforced with a stiffening arrangement to match the door manufacturer's requirements to prevent leakage and exceeding the allowable stresses.

7.2.4 Design Qualification Test.

Doors are required to be qualified by the Naval Technical Authority. Each weathertight door shall be tested in accordance with the following requirements:

7.2.4.1 After installation onboard all weathertight doors shall be hose tested, the door shall not permanently deform. The water pressure shall be at least 0.2 mm² (2 bar), and the nozzle shall be held at a distance of maximum 1.5 m from the door or hatch cover.

7.2.4.2 Doors shall be tested in order to verify compliance with design tightness pressure. No adjustment or repairs are allowed during the test. At the completion of the test no parts shall require replacement, repair or adjustment. The door shall be re-hydrostatically tested following the cycle testing and qualify only if the hydrostatic test is successful.

7.2.4.3 Doors shall be fire tested to meet the requirements of the bulkhead in which they shall be installed.

7.2.5 Fixed Lights (Windows)

All weathertight doors, if specified, shall be designed to have the ability to incorporate a fixed light in the panel if specified. Fixed lights in weathertight doors shall be of sufficient strength to maintain the damage control strength requirements and resistance to damage features of the door in which it is installed. Fixed lights for doors facing the process plant shall be of heat-treated and shatterproof glass.

7.2.6 Technical Documentation

Drawings shall be provided for each type of door. The drawings shall provide the necessary design, engineering, manufacturing, and quality assurance requirements information necessary to enable the procurement or manufacture of an interchangeable item or end product that duplicates the physical and performance characteristics of the original product, without additional design engineering effort or recourse to the original design activity.

7.2.7 Materials

All external doors shall be of stainless steel plate, type AISI 316L, or alternatively AISI 316 with a maximum carbon content of 0.05 %. Door leaves shall be built for minimum repair requirements.

Doors shall be supplied with temporary preservation resistant to welding spatter and angle grinding grit. The door surface finish, after preservation removal, shall be stain resistant and require minimum maintenance. A procedure for stain removal (without dismantling the door) shall be provided.

All door leaves shall be fully insulated without any air pockets. Insulation fibers shall be sealed to prevent any fibers being released to the environment, and totally impervious to moisture. External stainless steel surfaces shall be blast cleaned with fine grade of aluminum silicate. Internal stainless steel surface shall be brushed finish, unless otherwise specified.

7.2.8 Acoustic requirements

Doors shall have, as a minimum, the same sound reduction requirement as the wall they are installed in, unless it can be documented that a lower value is acceptable, in order to meet the Rw value of complete wall/door assembly. The sound measurement test method shall be in accordance with ISO 140/3.

7.3 Hinged doors

7.3.1 All weathertight "A" class hinged doors and active leaf of all hinged double doors shall be self-closing, self-latching and central release (quick-acting type).

7.3.2 Doors shall be provided with three hinges, minimum. The hinge design shall allow for easy removal of the door. All hardware, hinges, locks, hooks and similar fittings shall be of AISI 316 L stainless steel or alternatively AISI 316 with a maximum carbon content of 0.05 %.

7.3.3 The door leaf or the gasket shall be easily adjustable after the door has been installed to ensure proper closure and compression of seals when closed.

7.4 Removable panels

7.4.1 Removable panels shall be installed where the doors alone do not provide enough space for passage of equipment for handling or maintenance.

7.4.2 Removable panels shall be certified to have the same fire rating as the bulkheads they are installed on.

7.4.3 Location and dimensions shall be confirmed in the detailed design phase and shall be compatible with cargo handling, without obstacles.



TECHNICAL SPECIFICATION	Nº I-ET-3010.1M-1350-190-P4X-001	REV. 0
BÚZIOS		SHEET 24 of 57
TITLE: ACCOMMODATION ARCHITECTURE MATERIALS AND EQUIPMENT SPECIFICATION		NP-2
		ESUP

8 PASSIVE FIRE PROTECTION (PFP) AND THERMAL/ACOUSTIC INSULATION

Ver onde citar classe “J”

8.1 Passive Fire Protection (PFP)

- 8.1.1 Passive Fire Protection (PFP) shall be applied on bulkheads, doors, windows, and penetrations, in accordance with applicable rules and regulations of IMO MODU CODE and SOLAS (1974 and amendments). All insulating materials shall be of non-combustible material and water repellent, and shall be suitable for the marine environment and the context in which they will be used. The materials shall not be corrosive to metal or emit any toxic gases or harmful dust. Bulkheads and decks that are to be insulated shall be provided with fixing pins and washers to retain the insulating material. The pins shall be welded to the structural material, e.g. steel surface.
- 8.1.2 Due to safety concerns, all insulation shall be faced, so as to minimize the release of any fibers. All cut and exposed edges shall be sealed.
- 8.1.3 The effect of fire protection shall be considered in the acoustical treatment. PFP and acoustical insulation may be considered as contributing to the thermal insulation.
- 8.1.4 The required thicknesses and reinforcement systems on the basis of the fire protection requirements shall be provided. PFP material thicknesses shall always be supported by the approval of an authority certification (e.g. by Classification Society).
- 8.1.5 All aspects of PFP material design, including manufacture and installation shall be in accordance with the latest editions of applicable codes and standards issued by internationally recognized organizations, associations and regulatory bodies, including, but not limited to, ISO International Standards Organization SOLAS Inter-Governmental Maritime Consultative Organization (IMCO), International Convention for the Safety of Life at Sea (SOLAS) 1974, including 1986 Amendments and (1996) Consolidated Edition. Also, material shall be in accordance with C.S rules.
- 8.1.6 Costs and maintenance requirements shall be considered as main factors in the evaluation of different PFP systems. The manufacturer shall provide information on the expected total service life costs of the proposed system, including topcoat replacement. Such data shall include experience gained to date in similar offshore installation conditions.
- 8.1.7 Passive protection shall guarantee to limit the temperature on the unexposed side to a level where personnel are safe or below the combustion temperature of combustible materials. It shall limit the stress levels in structural steel to a temperature where its load-bearing ability is not compromised. The Passive Fire Protection system shall be designed for the purpose of maintaining structural stability and integrity of all primary steel members for a defined period of time when exposed to a hydrocarbon fire. Fire protection performance shall be based on the ability of a minimum thickness of PFP material to restrict the rate at which heat is transmitted to the protected element. The criteria for the fire performance



TECHNICAL SPECIFICATION ^{Nº}	I-ET-3010.1M-1350-190-P4X-001	REV. 0
	BÚZIOS	
	SHEET 25 of 57	
TITLE: ACCOMMODATION ARCHITECTURE MATERIALS AND EQUIPMENT SPECIFICATION		NP-2
		ESUP

of the system shall be the acceptable steel temperature at the end of the fire exposure period to avoid collapse.

- 8.1.8 All PFP systems shall be tested at a recognized independent establishment to standard fire tests to classes A/B and to hydrocarbon fire test to class H. Suitable certification shall be available from approval authorities such as classification society to support all the fire protection requirements of the project.
- 8.1.9 The fireproofing material supplied for the project shall be manufactured using the same formulation as the material that has been subjected to hydrocarbon/fire tests by a recognized independent third party. Special attention shall be paid to the junction between the steel deck and insulation in order to avoid water penetration.
- 8.1.10 The PFP system shall be able to maintain fire performance over the service life of the installation. In this regard, the proposed PFP system's ability to satisfy the following requirements:
 - Resistance to weather cycling in offshore environments (corrosion resistance);
 - Impermeability (corrosion and mechanical resistance);
 - Resistance to flexing and vibration of the substrate (adhesion);
 - Chemical resistance to products liable to pollute it (hydrocarbons typical to oil and gas installations);
 - Mechanical shock (impact) resistance;
 - Abrasion and erosion resistance;
 - Resistance to wash down by high pressure water jets and typical cleaning agents;
 - Resistance to substrate temperature cycling during construction and operation;
- 8.1.11 Flexible type fireproofing shall have a finishing/protection suitable to the environment conditions in which it will be installed. Exposed fire insulated bulkheads in compartments where the movement of equipment or part is possible shall be covered with aluminum plate from the floor to the ceiling until 3.00m. The aluminum plate shall be perforated in noisy environment. Galvanic corrosion shall be avoided. Isolation shall be provided between aluminum plate and metallic pieces. Exposed deck thermal/acoustic insulation shall be covered with glass cloth. Blanket and plate fixations shall follow suppliers' recommendations.
- 8.1.12 All external cladding, if applicable, covering A- and H-rated insulation shall have fire rated gaskets between cladding and fixing brackets to maintain fire rating of the overall installation. Cladding covering thermal insulation shall have isolation gaskets between cladding and fixing brackets to avoid migration of condensation. The clad covering shall be installed in order to protect flexible material insulation, if exposed to the weather.
- 8.1.13 Special attention shall be paid to the junction between the steel deck/bulkhead and insulation in order to avoid water penetration.
- 8.1.14 The fireproofing material shall be asbestos free.



TECHNICAL SPECIFICATION	Nº	I-ET-3010.1M-1350-190-P4X-001	REV.	0
BÚZIOS			SHEET	26 of 57
TITLE: ACCOMMODATION ARCHITECTURE MATERIALS AND EQUIPMENT SPECIFICATION			NP-2	
			ESUP	

- 8.1.15 The bulkheads, exposed ceilings and floors where required by the HVAC discipline, shall be provided with a thermal insulation according to I-ET-3010.1M-5250-300-P4X-001 - HVAC SYSTEM DESIGN.
- 8.1.16 “H” class insulation can be intumescent fire protection coating, high performance reinforced epoxy, solvents free. Thickness shall be in accordance with manufacturer instructions. “H” class insulation shall be able to protect the structure and bulkheads against hydrocarbon fire, preserving its integrity during the specified time.
- 8.1.17 Stairway and lift trunk shall be enclosed by “A” class walls and be protected by self-closing “A” class doors at all decks, in order to avoid fire spreading from one deck to another.
- 8.1.18 Draught Stops shall be installed above ceiling, in order to avoid fire spreading.
- 8.1.19 At the intersection between a higher class division and another one with lesser degree of protection, an extended fireproofing is to be provided to a distance of at least 1.0 meter beyond the intersection. See I-ET-3010.00-5400-433-P4X-001 – PASSIVE FIRE PROTECTION.
- 8.1.20 Rigid type fireproofing applied by means of spray system shall not be used on ceiling / bulkheads of closed in areas. See I-ET-3010.00-5400-433-P4X-001 – PASSIVE FIRE PROTECTION.
- 8.1.21 Passive Fire Protection purpose shall provide the unit with the required fire safety levels, aiming to:
- Minimize the action of fire, restraining it to its origin;
 - Protect human life;
 - Protect equipment and systems, mainly those essential to the safe operation of the unit;
 - Safeguard the unit’s structural elements, in such a way as to preserve the designed structure’s mechanical strength.
- 8.1.22 Typical insulation details shall as far as practicable be standardized throughout the installation, and shall be reflected in the wall type/deck type details and schedules. Details showing fire insulation with specific fire direction identified shall be provided.
- 8.1.23 Insulation details shall be suitably referenced on project documentation so that they may be used for verification of installed insulation as part of mechanical completion activities, and for repair work or modification during later phases.
- 8.1.24 The following issues shall be considered for determination of the type and degree of the Passive Fire Protection:
- Evaluation of the equipment layout and division of the unit into risk areas;
 - Indication of the type of protection, with its respective classification, for each implementation area;
 - Indication of the direction of the fire acting against shields;
- 8.1.25 Passive Fire Protection (PFP) for structural elements shall be in accordance with document I-ET-3010.00-5400-433-P4X-001 – PASSIVE FIRE PROTECTION.



TECHNICAL SPECIFICATION	Nº	I-ET-3010.1M-1350-190-P4X-001	REV.	0
	BÚZIOS		SHEET	27 of 57
	TITLE: ACCOMMODATION ARCHITECTURE MATERIALS AND EQUIPMENT SPECIFICATION			NP-2
				ESUP

8.2 Thermal Acoustic Insulation

- 8.2.1 The insulated floors, ceilings and bulkheads shall be of an approved type and shall be of non-combustible material. The insulation material shall be laid in such a way that condensation and noise is avoided and shall be securely fastened.
- 8.2.2 The insulation shall be flexible type.
- 8.2.3 Sound absorbing cassettes may be mounted to bulkheads, walls, ceilings and underside of decks in areas where additional absorption of sound is required. Sound absorption data for the cassettes shall be provided from a recognized acoustic laboratory. The cassettes shall have good sound absorption properties in the 63 Hz to 4 000 Hz frequency range.
- 8.2.4 The acoustic insulation shall be selected and detailed to achieve the sound absorption and sound reduction requirements specified in the project documentation. The insulation shall follow the NRC (Noise Reduction Coefficient) recommended by the requirements of the noise prediction study.
- 8.2.5 Exposed bulkheads thermal/acoustic insulation shall be covered with aluminum plate from the floor to the ceiling or until 3000 mm in order to be protected against mechanical shocks. The aluminum plate shall be perforated in noisy environment. Galvanic corrosion shall be avoided. Isolation shall be provided between aluminum plate and metallic pieces. Exposed deck thermal acoustic insulation shall be covered with glass cloth. Blanket and plate fixations shall follow manufacture recommendations.
- 8.2.6 Special attention shall be paid to the junction between the steel deck and insulation in order to avoid water penetration.
- 8.2.7 Thermal insulation shall be applied on the boundary surfaces of all conditioned spaces or unconditioned spaces exposed to the weather.
- 8.2.8 All aspects of thermo-acoustic insulation material design, including manufacture and installation shall be in accordance with the latest editions of applicable codes and standards. Also, material shall be in accordance to C.S rules.

8.3 "A" Class Bulkhead and Deck

- 8.3.1 Divisions formed by decks and bulkheads which comply with:
- They shall be constructed of steel or other equivalent material;
 - They shall be suitably stiffened;
 - They shall be so constructed as to be capable of preventing the passage of smoke and flame to the end of the one-hour standard fire test.
 - They shall be insulated with materials so that if either face is exposed, the average temperature of the unexposed side will not rise more than 140°C above the original temperature, nor will the temperature at any one point, including any joint, rise more than 180°C above the original temperature, within the time listed below:

CLASS MINUTES

A-60	60
A-30	30



TECHNICAL SPECIFICATION	Nº	I-ET-3010.1M-1350-190-P4X-001	REV.	0
	BÚZIOS		SHEET	28 of 57
	TITLE: ACCOMMODATION ARCHITECTURE MATERIALS AND EQUIPMENT SPECIFICATION			NP-2
				ESUP

A-15	15
A-0	0

8.3.2 Acceptable test procedure: IMO Resolution A. 754 (18).

8.3.3 Joints and reinforcements shall receive continuous welding to guarantee perfect tightness. Class A horizontal and vertical bulkheads shall be comprised of aluminum plate supports, duly reinforced and installed to assure gas and smoke impenetrability.

8.4 "B" Class Bulkhead

8.4.1 Divisions formed by decks, bulkheads, ceiling or linings which comply with the following:

- They shall be so constructed as to be capable of preventing the passage of flame to the end of the first half-hour standard fire test;
- They shall have an insulation value so that if either face is exposed, the average temperature of the unexposed side will not rise more than 140°C above the original temperature, nor will the temperature at any one point, including any joint, rise more than 225°C above the original temperature, within the time listed below:

CLASS MINUTES

B-15	15
B-0	0

8.4.2 Acceptable test procedure: IMO Resolution A. 754 (18)

8.5 H-120 Class Bulkhead

8.5.1 Those divisions formed by decks and bulkheads which comply with the following:

- They shall be constructed of steel or other equivalent material;
- They shall be suitably stiffened;
- They shall be so constructed as to be capable of preventing the passage of smoke and flame after 120 minutes exposure to a hydrocarbon fire test;
- They shall be so insulated that, if the designated exposure face(s) is (are) exposed to the hydrocarbon fire test for 2 hours, the average temperature of the unexposed face will not increase at any time during the test by more than 140°C above the original temperature, nor shall the temperature at any point of the face, including any joint, rise more than 180°C above the original temperature, within 2 hours.
- Structures intended to be load bearing should either be tested under representative conditions of loading and restraint or have the temperature of the load bearing medium monitored during the test to demonstrate that the maximum temperature reached would not have resulted in loss of strength or stiffness or excessive expansion such as to impair the load bearing capacity.

8.6 H-60 Class Bulkhead

8.6.1 Those divisions formed by decks and bulkheads which comply with the following:

TECHNICAL SPECIFICATION	Nº I-ET-3010.1M-1350-190-P4X-001	REV. 0		
			BÚZIOS	
			SHEET 29 of 57	
TITLE: ACCOMMODATION ARCHITECTURE MATERIALS AND EQUIPMENT SPECIFICATION		NP-2		
		ESUP		

- They shall be constructed of steel or other equivalent material;
- They shall be suitably stiffened;
- They shall be so constructed as to be capable of preventing the passage of smoke and flame after 120 minutes exposure to a hydrocarbon fire test;
- They shall be so insulated that, if the designated exposure face(s) is (are) exposed to the hydrocarbon fire test for 1 hour, the average temperature of the unexposed face will not increase at any time during the test by more than 140°C above the original temperature, nor shall the temperature at any point of the face, including any joint, rise more than 180°C above the original temperature, within 1 hour;
- Structures intended to be load bearing should either be tested under representative conditions of loading and restraint or have the temperature of the load bearing medium monitored during the test to demonstrate that the maximum temperature reached would not have resulted in loss of strength or stiffness or excessive expansion such as to impair the load bearing capacity.

8.7 H-0 Class Bulkhead

8.7.1 Those divisions formed by decks and bulkheads which comply with the following:

- They shall be constructed of steel or other equivalent material;
- They shall be suitably stiffened;
- They shall be so constructed as to be capable of preventing the passage of smoke and flame after 120 minutes exposure to a hydrocarbon fire test;
- Structures intended to be load bearing should either be tested under representative conditions of loading and restraint or have the temperature of the load bearing medium monitored during the test to demonstrate that the maximum temperature reached would not have resulted in loss of strength or stiffness or excessive expansion such as to impair the load bearing capacity.

8.7.2 Fire Resistance Rating for load bearing structural elements is:

The ability of the structural element to withstand the effects of a defined fire (e.g. hydrocarbon time-temperature profile) for a specified time without loss of the fire separating and load bearing function of divisions and without loss of the load bearing function of structural members.

8.7.3 The Fire Resistance Rating for load bearing elements is determined on the basis of the factors listed below:

- The structural element being considered;
- The required duration of the load bearing ability;
- The fire load (or heat flux in kw/m²);
- The restricted critical core temperature.

8.7.4 Every load bearing member shall be suitably fire protected to meet the requirements of the fire resistance rating.

8.8 J-60 Class Bulkhead



TECHNICAL SPECIFICATION	Nº I-ET-3010.1M-1350-190-P4X-001	REV. 0
BÚZIOS		SHEET 30 of 57
TITLE: ACCOMMODATION ARCHITECTURE MATERIALS AND EQUIPMENT SPECIFICATION		NP-2
		ESUP

8.8.1 Those divisions formed by decks and bulkheads which comply with the following:

HOLD

8.9 J-0 Class Bulkhead

8.9.1 Those divisions formed by decks and bulkheads which comply with the following:

HOLD

8.10 Delivery, Storage, Handling and Disposal

8.10.1 All PFP materials shall be delivered in original, sealed containers and shall be inspected for integrity.

8.10.2 PFP materials shall be stored in strict accordance with the manufacturer's instructions. Waste should be kept to a minimum and any left over material should be allowed to cure before being disposed of in accordance with local and/or national regulations.

9 FLOOR COVERING SYSTEM

9.1 General

9.1.1 All floor materials finishing shall be selected in order to comply with the conditions and functional requirements of each room/area. They shall be easy to maintain and clean. Materials, adhesives, sealing mastics, leveling screed, etc. shall be compatible and shall not emit toxic gases and dust.

9.1.2 The use of combustible materials in Accommodations must comply with SOLAS, Chapter II-2, Part B, Regulations 5 (Fire growth potential) and 6 (Smoke generation potential and toxicity). Combustible or toxic material shall not be used.

9.1.3 Catalogues shall be provided with technical characteristics, applicable test reports and standard floor colors and submitted to PNBV approval.

9.1.4 Deck compound shall be installed after steel decks have been thoroughly cleaned, dried and painted with primer to prevent corrosion and obtain good adhesion. In rooms with gullies, the covering shall be inclined towards these, to obtain proper drainage.

9.1.5 All floor covering system material shall be provided in order to comply with noise and vibration analysis report developed in the detailed design phase based on I-ET-3010.1M-1200-300-P4X-002 – NOISE CONTROL REQUIREMENTS FOR ACCOMMODATION.

Notes:

a. Manufacturer updated information shall be considered during the detailed design phase and proposal analysis. Floor covering system properties and characteristics shall be maintained.

b. Equivalent material is accepted provided the material properties are suitable to fulfill the noise prediction and the floor covering characteristics required for each area.

TECHNICAL SPECIFICATION	Nº I-ET-3010.1M-1350-190-P4X-001	REV. 0		
			BÚZIOS	
			SHEET 31 of 57	
TITLE: ACCOMMODATION ARCHITECTURE MATERIALS AND EQUIPMENT SPECIFICATION		NP-2		
		ESUP		

- 9.1.6 The following top floor coverings shall be installed according to Basic Design drawings:
- Floating floor
 - Monolithic floor
 - Anti-acid ceramic tiles;
 - Elevated floor systems;
 - Rubber tiles or sheet (antistatic/non-conductive type);
 - Wooden Deck;
 - FRP grating (external use);
 - Floor grating (internal use);
 - Painted Steel Deck (anti-skidding).

9.2 Primary Deck Covering

- 9.2.1 The primary deck shall be installed on interior deck areas, to level the surface prior to the application of deck finishing materials such as: tiles, rubber or painting, only in combination with a top leveling product.
- 9.2.2 Primary deck covering shall be used as a self-leveling for deck, (proper for wet and/or dry area) before applying finishing materials such as rubber sheets, monolithic finishing (epoxy painting) or ceramic tiles (resistant to H₂SO₄).
- 9.2.3 The primary deck covering shall be selected according to required properties of each deck area to be covered:
- Fire-retardant;
 - Self-leveling;
 - Lightweight;
 - Thermal insulation;
 - Fast drying.
- 9.2.4 The primary deck shall be one component mortar, based on polymer modified mortar, flame resistance, flexible and able to provide a perfect flooring installation avoiding cracks and water penetration between joints. The primary covering and the top leveling product must have high resistance to the deformations that the steel deck is submitted (bending, compression and traction), without the use of wire mesh and clamps.
- 9.2.5 The primary deck covering shall be manufactured in accordance with ISO 9001 / 14001 quality assurance.
- 9.2.6 Floating floor maybe required to be integrated to the floor systems in order to minimize airborne noise. The detailed design shall follow the noise prediction study and provide the insulation if required so.

9.3 Floating floor



TECHNICAL SPECIFICATION	Nº	I-ET-3010.1M-1350-190-P4X-001	REV.	0
	BÚZIOS		SHEET	32 of 57
	TITLE: ACCOMMODATION ARCHITECTURE MATERIALS AND EQUIPMENT SPECIFICATION			NP-2
				ESUP

9.3.1 The deck covering system shall improve and take care of noise reduction issues and prevent vibration of the steel structure. The vibration energy shall be absorbed and therefore be not available to radiate as sound to the protected area or to other areas of the unit. The material shall not recover at the same rate as which it is distorted, and energy from the vibration shall be therefore absorbed, leaving less to be radiated as noise. Cabins or compartments near of trunks (including staircases), Cabin located near hospital (cabin nr 208), Hospital, Video Conference Room, Auditorium and C.C.R. shall use floating floor in order to avoid excessive noise values caused by vibration. The installation of floating floor shall be provided if required during detailed design phase, in accordance with Noise Control Report.

9.4 Monolithic floor

9.4.1 The monolithic floor covering shall be a two component epoxy with mineral filler which in combination with quartz can be used as non-skid finishing material. The monolithic floor shall be designed and suitable to be used as deck coverings for indoor and outdoor area.

9.4.2 Beyond easy hygienic cleaning, the chemical and mechanical resistances are basic factors. Chemical resistance is important due to the used products for hygienic cleaning, disinfection, washing, and bactericidal are chemically aggressive and allied to high temperatures may corrode the floor. Therefore it is necessary to make the specification adjusted to the required floor resistance. The mechanical resistance is also important to support the impacts and blows in the floor, due to the efforts of transit of wheeled cars, manipulation and drags of equipment possibly will damage it.

Characteristics:

Basis. Two-component epoxy with mineral filler.

Density: Base: Approx. 1.2 g/cm³.

Recommended thickness: Min. 3 mm (max thickness shall not exceed 10 mm)

9.5 Anti-Acid Ceramic Tiles (H₂SO₄ resistant)

9.5.1 The anti-acid ceramic tiles and correspondent skirting board shall be industrial type, chemical (H₂SO₄) and abrasive resistant, with high mechanical strength against impacts and protection against corrosion by aggressive substances, in light gray color.

9.5.2 Joints between tiles shall be compatible with anti-acid ceramic, chemical and abrasive resistant and anticorrosive of high resistance. Distance between tiles (joints) shall be 6 to 10 mm.

9.5.3 The deck compound shall be proper to anti-acid ceramic tile's installation and shall be provided in accordance with manufacturer's instructions.

9.5.4 Anti-acid ceramic tiles shall be installed in Battery Rooms, as indicated in the document I-ET-3010.00-5140-700-P4X-001 – SPECIFICATION FOR ELECTRICAL DESIGN FOR OFFSHORE UNITS, item 3.13.8: "Electric batteries rooms shall have acid resistant floor".

9.6 Elevated Floor Systems



TECHNICAL SPECIFICATION	Nº	I-ET-3010.1M-1350-190-P4X-001	REV.	0
	BÚZIOS		SHEET	33 of 57
	TITLE: ACCOMMODATION ARCHITECTURE MATERIALS AND EQUIPMENT SPECIFICATION		NP-2	
		ESUP		

- 9.6.1 The elevated floor system shall be proper to be installed where electrical panels will be installed.
- 9.6.2 The elevated floor shall have features that make services easily accessible and shall provide quick access to the power and cabling that lies below the floor. It shall result in faster installations and increased performance.
- 9.6.3 The elevated floor system shall have the following characteristics:
- Heavy duty type.
 - Epoxy paint finishing.
 - Interchangeable with other panel strengths.
 - Non-combustible.
 - Grounding and electrical continuity.
 - Class A flame spread and smoke development rating.
 - Lightweight.
- 9.6.4 Elevated floor characteristics (heights, capacities) shall be adequate to requirements of each room where the system will be installed.
- 9.6.5 The system indicated in this document represents the minimum requirements to be considered and shall be confirmed in the detailed design phase, according to the cargo handling design – document I-ET-3010.1M-5266-630-P4X-001 – Topside Mechanical Handling Procedures.
- 9.6.6 Performance Requirements:
- Pedestals:
 - a. Axial Load: Pedestal assembly shall sustain around 2200 kg (minimum) axial load without permanent deformation.
 - b. Overturning Moment: Pedestal assembly shall provide an average overturning moment around 450 kg (minimum).
 - Stringers:
 - a. Midspan Concentrated Load: Stringer shall be capable of withstanding a concentrated load around 200 kg (minimum).
 - Floor Panels:
 - a. Concentrated Load: Panel shall be capable of supporting a concentrated load of 567 kg (minimum) placed on a one square inch area, at any location on the panel.
 - b. Flammability: System shall meet Class A Flame spread requirements for flame spread and smoke development. Tests shall be performed in accordance with ASTM-E84-1998, Standard Test Method for Surface Burning Characteristics for Building Materials.
 - c. Combustibility: Access floor panels shall qualify as noncombustible by demonstrating compliance with requirements of ASTM E 136, Standard Test Method for Behavior of Materials in a Vertical Tube Furnace at 750°C.
- 9.6.7 Design Requirements:



TECHNICAL SPECIFICATION	Nº	I-ET-3010.1M-1350-190-P4X-001	REV.	0
	BÚZIOS		SHEET	34 of 57
	TITLE: ACCOMMODATION ARCHITECTURE MATERIALS AND EQUIPMENT SPECIFICATION			NP-2
				ESUP

- Access floor system: where indicated on the design documents, shall consist of modular and removable all steel panels and supported on all four edges by structural steel members which are designed to bolt onto adjustable height pedestal assemblies forming a modular grid pattern.
- Panels shall be easily removed by one person with a lifting device and shall be interchangeable except where cut for special conditions.
- Quantities, finished floor heights and location of accessories shall be as specified on the detailed design drawings.

Panel Components:

Floor Panels:

- Shall consist of a top steel sheet welded to a formed steel bottom pan. Mechanical or adhesive methods for attachment of the steel top and bottom sheets shall not be used.
- Panels shall have an electrically conductive epoxy paint finishing.

9.7 Rubber Tiles or Sheet (antistatic/non-conductive type)

9.7.1 High and low-voltage electrical control panels rooms shall have non-conductive/antistatic flooring. The rubber finishing shall comply with the following requirements:

- Type II – ABC (ozone, fire and oil resistant) and minimum Class 0 (tested for 5kv) for panels with rated voltage up to 690V and minimum Class 1 (tested for 10 kv)for panels with rated voltage above 690V, according to ASTM D-178-01 requirements;
- Halogen free;
- Smoke density test and toxicity according to ISO 5659, part 2 and IMO Res. MSC 61(67);
- Heavy traffic.

9.7.2 The rubber flooring shall be installed in front and behind electrical panels and shall provide staff safety when working on live voltages. The arrangement shall avoid islands without rubber flooring, to make it easy the handling of movable equipment over the floor.

9.7.3 The rubber sheet shall be installed above steel deck, elevated floor or primary deck/ light weight self-leveling compound, according to indicated on Arrangement drawings.

9.8 Wooden Deck

9.8.1 Wooden shock-protection pads shall be provided for all compartments and/or areas where cargo handling is required. For these areas, the wooden shock-protection pads design shall be proper to resist against heavy loads and impact.

9.8.2 The wooden deck shall be made of hard wood suitable for cargo handling area, and shall be certified by a state environment agency. The design shall allow its use in appropriate terms of safety and maintenance.

9.8.3 The wooden decks, which are exposed to the weather, shall be protected with naval varnish.

9.8.4 The wooden deck shall be applied in:

HOLD

9.9 FRP Grating (external use)

9.9.1 FRP gratings shall be installed on external spaces where the leveling of the floor shall be increased to the threshold height in order to provide an easy transit of wheeled cars and cargo handling devices and walkway external area.

9.9.2 FRP gratings have a slight resiliency that makes them comfortable to stand on for long periods. The pultruded section shall be corrosion resistant, slip resistant, light weight, high strength-to-weight ratio, non-conductive, non-magnetic, fire retardant, impact resistant and low maintenance. Pultruded grating shall be assembled in "H" sections linked by rod per distance into panel.

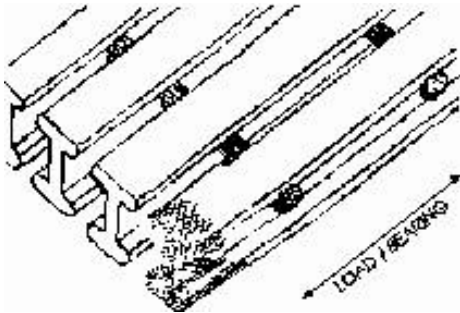

9.9.3 For specification, refer to I-ET-3010.00-1352-130-P4X-001 - SPECIFICATIONS FOR FLOOR GRATINGS, TRAY SYSTEMS AND GUARDRAILS MADE OF COMPOSITE MATERIALS.

9.10 Floor Grating (internal use)

9.10.1 Floor gratings shall be installed on internal spaces where the leveling of the floor shall be increased to the threshold height in order to provide an easy transit of wheeled cars and cargo handling devices and walkway from external area.

9.10.2 Floor gratings made of fiberglass shall not be installed in closed areas.

9.10.3 Floor grating shall be made of stainless steel or aluminum, with adequate spacing between the parts to make easier its maintenance and passage of workers and trolleys.

9.10.4 Floor grating shall be insulated to prevent corrosion.

9.11 Painted Steel deck (anti-skidding)

9.11.1 Painted steel deck shall be anti-skidding, high abrasion resistance and high mechanical resistance.

9.11.2 For specification, refer to I-ET-3010.00-1200-956-P4X-002 – GENERAL PAINTING.

9.11.3 Painted steel deck (anti-skidding) shall be used in HVAC Room, Normal Panels Rooms, Transformer Room and CO2 Central Room.

TECHNICAL SPECIFICATION	Nº I-ET-3010.1M-1350-190-P4X-001	REV. 0		
			BÚZIOS	
			SHEET 36 of 57	
TITLE: ACCOMMODATION ARCHITECTURE MATERIALS AND EQUIPMENT SPECIFICATION		NP-2		
		ESUP		

10 FIRE RATED WINDOWS

10.1 General

- 10.1.1 Fire rated windows shall be at least “A” Class, certified to have the same fire rating as the wall they are installed in, non-opening type, designed to be welded on steel bulkheads. The window units shall consist of a 6 mm (minimum) main frame, a sealed condensation free glass panel, a fixing frame (made of stainless steel) and an adjustable internal frame. Gasket between steel bulkhead and outer frame shall be provided.
- 10.1.2 The window system shall include a telescopic internal frame for accurate and flexible installation. The windows boxes shall be insulated and made of reinforced polyester, or galvanized steel painted.
- 10.1.3 The windows shall have type approval according to IMO Resolution A754 (18) based upon fire test against the toughened safety glass. The windows shall have toughened safety glass dimensioned as per ISO 21005 and ISO 1095 (sidescuttles) and shall have mechanical strength as required by ISO 3903 and ISO 1751 (sidescuttles).
- 10.1.4 The distance from steel deck to the window center shall be 1600 mm.
- 10.1.5 For dimensions and class of Accommodations’ windows refer to document I-DE-3010.1M-1350-190-P4X-009 - ACCOMMODATION INSULATION, DOORS AND WINDOWS ARRANGEMENT. Characteristics shall be confirmed in the detailed design phase.

10.2 Sound Characteristics

- 10.2.1 The windows shall as far as possible be soft connected to the steel structure and treated with structure borne noise damping material.
- Sound reduction:
- Lab tested up to $R_w = 53$ dB
 - Tested on platform $R_w = 60$ dB
- 10.2.2 All material construction shall be provided in order to comply with noise and vibration analysis report developed in the detailed design phase.
- 10.2.3 The noise of Accommodations shall be in accordance with I-ET-3010.1M-1200-300-P4X-002 – NOISE CONTROL REQUIREMENTS FOR ACCOMMODATION.

11 FURNITURE

11.1 General

An expert architecture company to be approved by PETROBRAS shall carry out the complete design and materials specification furnished for Living Quarters. Furniture materials shall be provided in accordance with IMO FTP Code.

Manufacturer shall provide the following type approval and fire test procedures:

11.2 IMO-testing (marine):



TECHNICAL SPECIFICATION	Nº	I-ET-3010.1M-1350-190-P4X-001	REV.	0
	BÚZIOS		SHEET	37 of 57
	TITLE: ACCOMMODATION ARCHITECTURE MATERIALS AND EQUIPMENT SPECIFICATION		NP-2	
		ESUP		

IMO MSC. 61(67), Annex 1, Part 5 and 6, IMO Res A.653 (16), IMO Res A.687 (17): Spread of flame;

IMO MSC. 61(67), Annex 1, Part 2, ISO 5659-2 med FTIR: Analysis, Smoke and toxicity;

IMO Resolution MSC. 61 (67), Annex 1, Part 1: Non-combustible;

IMO A.471(XII) amended by IMO Res A 563 (14): Resistance to flame of vertically supported textiles and films;

IMO MSC. 61(67), Annex 1, Part 8, IMO Res A.652 (16): Ignitability of upholstered furniture;

11.3 Furniture characteristics:

All furniture shall be built of plywood (naval type) coated with fire retardant melamine laminate, unless otherwise specified. All accessories shall be stainless steel made.

All furniture with doors and/or drawers shall be supplied with 4 keys, at least.

Office workstations shall be designed in order to achieve maximum users comfort. All the workstations shall be provided with trays or ducts for cable routing and free surface for large screens. The workstations shall be supplied by specialized manufacturer (industrial production), with items that are in compliance to ergonomics requirements (**Refer to NR-17**). As a result, the design may be as simple as possible and fit the worst case of physical dimension and environmental conditions for offshore ambient.

Workstations layout should provide an adequate place for all equipment and materials that the users must have at hand during their activities. The working environment shall enable computer users to avoid improper working postures. The use of computers require the possibility of adjustments, posture changes during the work shift and organization of work area involving chair, keyboard, mouse, monitor, phone, etc.

The following aspects for computer desk and/or work stations shall be implemented:

- Allow assembly of the working surfaces in a range of 540mm to 780mm.
- Have adequate work space on the working surface so that the user has the frequently used work accessories within reach without getting into stressful posture.
- Have sufficient clearance under the desk for free movement of user's knees & legs and to get close enough to the input devices.

The following aspects for chairs shall be implemented:

- Have good back rest preferably with lumbar support and seat pan should be wedge shaped.
- Have height adjustability.
- Have five supporting points for better stability (except no wheeled chair).
- The chairs wheels shall have to be adequately specified to the type of floor and use of the chairs.
- Use of footrest is recommended to get full support to the user's legs.

The following aspects for monitors shall be implemented:

- Position the Monitor in front of the user usually at arm's reach between 45cm (18") and 61cm (24").



TECHNICAL SPECIFICATION	Nº	I-ET-3010.1M-1350-190-P4X-001	REV.	0
BÚZIOS			SHEET	38 of 57
TITLE: ACCOMMODATION ARCHITECTURE MATERIALS AND EQUIPMENT SPECIFICATION			NP-2	
			ESUP	

- Position lights in relation to Monitor so as to avoid direct glare.
- The top of the screen should be at the same height as seated eye level.
- Monitor arm or support shall provide optimal position to ensure a relaxed head and neck posture.

The following aspects for keyboards shall be implemented:

- The computer keyboard should be about as high as the elbow and in front of the user.
- The keyboard should allow the user to rest fingers on the middle row of keys and maintain a straight (neutral) wrist posture.
- The keyboard tray should allow the user to adjust the angle of the surface so that the user's wrists and elbows can be in neutral or slightly downward position during keying.

The following aspects for mouse shall be implemented:

- Elbows should be close to the body and bent at an angle around 90 degrees with straight wrists while holding the mouse.
- The user should not be reaching out with a straight arm forward or to the side while using the mouse.

The following aspects for telephones shall be implemented:

- Use of Headset shall be evaluated during the detailed design phase and adopted whenever the operator tasks analysis suggests so.

The following aspects for furniture (in general) shall be observed and implemented:

- Berths shall have rails to avoid falls with minimum height of 300mm and a length of 1200mm. The rail shall be designed and constructed with a solid connection to the berth structure in order to support the user's weight while climbing the stairs and entering the berth. The users often use the rails as supports for their body weight.
- The stairs structure shall be stainless steel and shall be fixed to the berths and solid enough to support the user's weights. The stair steps shall be stainless steel, non sleep type.
- Berths shall have a stainless steel plate for identification, individual fluorescent light and one berth shelf. The berth shelf shall be retractable type.
- Writing desks shall have reading lights (fluorescent type).
- Bookshelves and sideboards shall have adjustable bars against roll (if applicable).
- Textiles shall be of flame retarding type according to Authorities requirements.
- Equipment, benches and material finishing for industrial/service areas shall be compatible with the use and functionality of work activity. Work benches and work desks shall be made of hard wood and steel structure for workshops and made of stainless steel for galley, hospital and etc. The design of these benches shall be developed considering the comfort of its users and be provided with facilities for material storage (shelving, drawers, etc.). The dimension of the benches shall follow the basic design. Ergonomic evaluation shall be developed in order to guarantee the work organization.
- Side tables shall be provided with lamps.



TECHNICAL SPECIFICATION ^{Nº} BÚZIOS TITLE: ACCOMMODATION ARCHITECTURE MATERIALS AND EQUIPMENT SPECIFICATION	I-ET-3010.1M-1350-190-P4X-001	REV. 0
	SHEET 39 of 57	
	NP-2	
ESUP		

- TV installation plugs, connections and devices, including wood shelf for TV support or TV support shall be provided for all cabins. TV support shall be fixed on the bulkhead, not in the ceiling in order to avoid injuries against its users.

11.4 Central control room furniture and accessories:

Central Control Room furniture shall be provided by specialized IT furniture manufacturer. IT equipment must be as easy as possible to understand and use, must not distract, and must not cause adverse effects on human performance or health. All characteristics regarding workstations described on item 10.2 shall be implemented for C.C.R. ambient as well, except when noted. C.C.R. benches design shall consider that the CPUs are remotely located in the C.C.R. Equipment Ambience. Coat hooks (with two hooks each) shall be provided close to the C.C.R. entrances. Emergency switches or similar devices shall be located and protected in order to avoid its use by accident.

11.5 Central Control Room benches general description:

Steel plate structure, with antirust treatment and epoxy electrostatic painting, constituted of self supporting modular frames; frontal wall having openings and “U” trays or ducts for cable and wiring installation, independent for power and network (data) cables; structural arm for installation and top bench support: the main area (work area) in compound wood structure and the secondary area (adjustable support for monitors) in steel plate, connected to the frame by simple mortise; panels of back closing in special wood with at least 30 mm of thickness.

The bench design shall allow the connection between modules. The benches shall allow adjustment of the working surfaces height in a range of 730mm to 780mm, as well as the keyboards surfaces. The workstations layout shall be based on the activities developed in all work conditions, including emergency drills when the exchange of information between operators can require voice, paper or electronic communication.

11.6 C.C.R. and workstation’s offices chairs:

a	Seat height (Regulation interval) (fixed workstation and adjustable chair system)	470	570
a	Seat height (Regulation interval) (Adjustable workstation and adjustable chair)	370	530

Operation chairs shall be adjustable regarding the height of seats, backrests and armrests. These chairs shall be provided for all offices and C.C.R. workstations. The chairs shall be resistant to continuous use by different people (height and weight, 130 kg minimum) during 24h work journeys. Seats shall have pneumatic-height adjustability in order to guarantee that the feet are supported by floor. The angle between legs and floor shall be 90°. Seat material must be air weave

and resistant to distribute pressure evenly and thermal comfort to the body. If the chair does not allow the ideal angle, feet rests become necessary and shall be installed. The frontal edge of the chair seat should be curved to diminish or increase, adapting to the user’s thigh size, so that it won’t press the back part of the knee or leg, disturbing the correct blood circulation.

Chair backrest shall provide lumbar support, thoracic and sacra-pelvic areas, however the width of this support shall not interfere in regards of arms movements. The back should be



TECHNICAL SPECIFICATION	Nº	I-ET-3010.1M-1350-190-P4X-001	REV.	0
	BÚZIOS		SHEET	40 of 57
	TITLE: ACCOMMODATION ARCHITECTURE MATERIALS AND EQUIPMENT SPECIFICATION		NP-2	ESUP

made of high-resistance injected material. The backrest shall be resistant, with enough flexibility to recline and move in a continuous flow with the range movements of the spine, regarding a comfortable posture.

The backrest shall have an inclination adjustment from 95° to 120° degrees (minimum) in relation to the chair seat, maintaining simultaneously the harmonic tilt to the natural pivots points of the body. The C.C.R. chairs must have a correct pressure distribution to the whole body, in all the reclined positions, as well as in the upright position to guarantee the well-being of the user.

Both, seat and backrest should be made of breathable material, allowing the conduction of the heat and dispersion of moisture of the body, so as to avoid uncomfortable foam-padded cushions that obstruct thermal body comfort. Armchair is the option for postural and support alternation, however, the following should be observed:

- The length of the armrests must not block the approach to the table, as this will cause the user to lose back support.
- The height of the armrests must be adjusted so that the upper arm and forearm forms an angle of approximately 90° (the min/max distance between the seat and armrest is approximately 13/20 cm).
- Guaranteed for more than 10yrs (24h/day-7days/week).
- No less than 90% recyclable, at least 40% recycled content.

The armchair shall have wheels, 2 ½” diameters, double wheels with internal brake (if applicable), black nylon wheels and yoke, soft polyurethane tread. The base shall be spinning, with central structure with pneumatic height-adjusting and composed by five blades of molten aluminum and no welding; epoxy powder electrostatic painting in metal black. Back and seat reclining mechanism, synchronized 2 to 1. This specification shall be followed for all work chairs located on above offices workstations (for the user, only) and C.C.R. operation benches (for all operators). All workstation guest seating shall be the same model described on item 10.2.4. The chairs shall have armrests and four feet with glides in stead of wheels.

11.7 Meeting room/Conference Room and workstation’s guest chairs:

Video conference/meeting rooms and workstations guest seating shall be a chair that fits all kinds of different people as it supports many different work styles. The chair shall be suitable for multiple uses and provided with the following characteristics:

- Shall have arm rests, die-cast aluminum finished with powder-coat epoxy.
- Shall have an aluminum structure and finished with power-coat epoxy.
- Shall have pneumatic seat-height and tilt-tension adjustments.
- Shall have breathable, resistant and flexible backrest and seat.
- Seat shall adapt to the body weight, should be air weave and must have a contoured support.
- Shall be comfortable for sitting during meeting periods.
- Shall have wheels, five feet chairs, 2 ½” diameters, double wheels with internal brake (if applicable), black nylon wheels and yoke, soft polyurethane tread. Meeting rooms/Video conference room chairs shall not have wheels otherwise required by PETROBRAS staff,



TECHNICAL SPECIFICATION	Nº I-ET-3010.1M-1350-190-P4X-001	REV. 0
BÚZIOS		SHEET 41 of 57
TITLE: ACCOMMODATION ARCHITECTURE MATERIALS AND EQUIPMENT SPECIFICATION		NP-2
		ESUP

during the detailed design phase. In this particular case, four feet with glides shall be provided.

- Materials should be easy maintenance and easy cleaning, anti-allergic, anti-adherent.
- Guaranteed for more than 10yrs (24h/day-7days/week).
- No less than 90% recyclable, at least 20% recycled content.

11.8 Mess Room chairs:

Mess Room seating shall be a chair that fits all kinds of different people as it supports many different styles. The chair shall be suitable for multiple uses and provided with the following characteristics:

- Shall not have arm rests.
- Shall have aluminum structure.
- Shall have breathable, resistant and flexible backrest and seat.
- Shall be easy to transport, with handle and stackable. Light-weighted.
- Seat shall adapt to the body weight, should be air weave and must have a contoured support.
- Seat shall be made of injection-molded perforated glass-filled polypropylene with waterfall edge for proper circulation.
- Shall not have wheels, instead shall have protection with interchangeable glides, four feet chairs.
- Materials shall be easy maintenance and easy cleaning, anti-allergic and anti-adherent.
- Guaranteed for more than 10yrs (24h/day-7days/week).
- No less than 90% recyclable, at least 20% recycled content.

11.9 Bookcases / Cupboards:

The following cupboards and bookcases shall be provided for C.C.R.:

Cupboards for files and folders

The cupboards shall have one part open, provided with shelves and the other part shall be fitted with doors, shelves and drawers. The open part shall be used for folders storage, which is often consulted the other part shall be provided for files storage and must be totally closed by doors and provided with shelves and drawers.

Personal equipment storage

The shoes locker shall be installed in front of the accommodation access entrance. Coats hooks shall be provided for helmets storage. The cupboards shall be fitted with doors, shelves and drawers and shall be suitable for personal equipment storage, as such radios, gloves and etc.

Cupboard for safety equipment

This cupboard is for life jackets storage as well signal box, and other equipment. The cupboards shall be placed in C.C.R. in operation area. Cupboard must have doors, shelves and be fitted with locks.



TECHNICAL SPECIFICATION	Nº	I-ET-3010.1M-1350-190-P4X-001	REV.	0
	BÚZIOS		SHEET	42 of 57
	TITLE: ACCOMMODATION ARCHITECTURE MATERIALS AND EQUIPMENT SPECIFICATION		NP-2	
		ESUP		

12 TOILET UNITS (WET UNITS)

12.1 General

The emphasis of the design shall be in the use of durable solutions to ensure maximum quality, comfort and the wellbeing of users. The units shall be manufactured considering the ease of handling and installation.

The Toilet units shall be manufactured according to the rules and regulations. All accessories shall be stainless steel and loose sanitary shall be chrome plated. All showers shall have hot and fresh water and shall be fitted with thermostat controlled mixers.

The toilet units shall be delivered with walls and ceilings manufactured in a sandwich construction with no open/visible insulation. All units shall be provided with piping maintenance access door 600 x 1800 mm (minimum dimensions).

The floor pan shall be fully tested watertight, blasted and primed before finishing. The floor finishing shall be monolithic type, epoxy painted. Wall/ceiling panels and door entrance (including frame, stainless steel ventilation grille, handles, hinges and accessories) shall be "B" class, PVC free, and certified according to recognized authorities. Shower cabinet shall be provided with acrylic and aluminum structure doors. For semi-submersibles and F.P.S.O. units, the Aluminum and acrylic structure shall be installed with latches in such way to prevent that they might open accidentally (due to unit movement), and shall be provided with sliding mechanism duly strengthened.

The toilet units for two people shall be provided with one electrical towel dryer and those for four people with two electrical towel dryers (minimum). All toilet units shall have an independent extended shower to the water closet (personal hygiene spray).

Toilet units entrance door shall have door adjuster and clear size around 1800 (H) x 600 (W) mm with sill height around 250mm. For Hospital toilet unit, the sliding door shall have 1000mm (W), minimum sill and door adjuster. Door lock shall have an indicator mortise latch.

Piping connections shall be as follows:

- Fresh Water Pipe – PVC flexible connections
- Hot Water Pipe - CPVC flexible connections
- Grey Water Pipe - PVC
- Sewage Pipe – Rubber Bend Connection
- Individual drainage for unit floor and shower.

Electric cabling shall be supplied with the toilet unit to make a single connection through a junction box to the external electrical source. Electrical switches for lighting shall be installed outside the toilet unit. Toilet unit dimensions shall be in accordance with Accommodation and Hospital arrangements.

12.2 Toilet unit equipment and accessories

The toilets units (including Hospital) shall be equipped as described bellow:

- AISI 306 stainless steel scupper grating.
- Grey water outlet pipe connection.



TECHNICAL SPECIFICATION	Nº	I-ET-3010.1M-1350-190-P4X-001	REV.	0
	BÚZIOS		SHEET	43 of 57
	TITLE: ACCOMMODATION ARCHITECTURE MATERIALS AND EQUIPMENT SPECIFICATION		NP-2	
		ESUP		

- Fresh water pipe connection.
- Connection B.S.P. Type
- Electrical cabling.
- Flexible metal conduit pipe.
- Door hinges (stainless steel).
- Porcelain wash-basin with hot and fresh water taps, including all fixing accessories and installed in a granite bench (overlap type), with cabinet.
- Toilet bowl porcelain made with cover (resistant acrylic or similar material). The toilet model shall be proper for gravity system and shall be fixed to the floor.
- Shower set
- Shower mixer
- Mixing tap
- Soap holder
- Spare paper holder
- Toilet paper holder
- Double hook (minimum quantity in accordance with cabin occupancy)
- Grab rail (to be installed near toilet bowls and showers)
- Cabinet with mirror and two sockets for razor. Electrical lighting fixture for ceiling and mirror shall be fluorescent type with independent switch IPW-55. The manufacturer shall guarantee a general lighting level of 150 Lux and 300 Lux for mirror.
- Electric towel dryer (minimum quantity in accordance with cabin occupancy).
- Towel rail (minimum quantity in accordance with cabin occupancy).
- Exhaust valve.
- Personal hygienic spray , with flexible connection and fixing accessories (chrome plated).

12.3 Industrial chemical toilet

It shall be installed one Industrial chemical toilet for men and women at the operation area. The chemical toilet shall be provided with volume tank (220L), collecting box, have dimensions 1.20 x 1.20 x 2.40m , antiskid floor, support for hoisting, System of constraint with key , forced ventilation and artificial illumination. Weight shall not exceed 95kg.

The toilet shall be manufactured in polyethylene and have the characteristics listed bellow:

- toilet bow (Box of dejections with seat)
- wash basin
- faucet (chrome plated)
- complete hydraulic installation
- toilet paper holder
- soap holder



TITLE: ACCOMMODATION ARCHITECTURE MATERIALS AND EQUIPMENT SPECIFICATION	TECHNICAL SPECIFICATION Nº	I-ET-3010.1M-1350-190-P4X-001	REV.	0
	BÚZIOS		SHEET	44 of 57
			NP-2	
		ESUP		

- exhaust valve
- personal hygienic spray, with flexible connection and fixing accessories (chrome plated).
- Two coat hooks.

The collecting box shall be provided as described bellows:

- Pneumatic unit (empty compressor)
- Lubrication - forced
- Refrigeration - wings heat spendthrifts
- Minimum required Power - 9 hp

13 SANITARY WARE AND ACCESSORIES

13.1 General

The design shall ensure that maintenance can be achieved without undue disruption to the equipment or interconnecting services, or the need, as far as is practicable, for specialized tools and knowledge. The design shall maximize the use of interchangeable components and shall utilize the concept of device change-out wherever possible. The manufacturer shall have a representative in Brazil in order to provide spare parts for maintenance. Sanitary ware shall be furnished and installed in accordance with arrangement drawings. Catalogues shall be provided and submitted to **PETROBRAS** approval.

Restrooms, showers cabins, laundry, galley, hospital, laboratory, dry provision, freezers room, workshops (all industrial rooms), mess room, corridors and garbage area shall have drains on the floor. The quantity of the drains shall consider the internal layout as well the compartments located bellow, in order to guarantee the functionality of the drain system and avoid leakage on electrical equipment. Drains shall be avoided above electrical equipment as far as practical.

Taps with rose connection (fresh water) for cleaning purpose shall be installed 500mm above floor finishing in the following compartments:

Galley, Mess Room, Dry Provision, Hospital and treatment Room, Garbage area, Restrooms, Changing Rooms, Workshops and Warehouse.

13.2 Characteristics

All the accessories listed in this specification (paper holder, soap dish, etc.) are to be of non recessed installation type, i.e., they are not to be inlaid in the lining, requiring fitting accessories such as screws, clamps etc. Plastic materials shall not be used, unless otherwise specified.

All showers shall have hot and fresh water and shall be fitted with thermostat controlled mixers. All restrooms shall have coat hooks in accordance with arrangement drawings. The bench with sinks (near mess room entrance) shall be granite made with overlap porcelain wash basins with taps (time delay type). Tap shall be electronic type that is activated by the approach of hands to the sensor. The interruption shall occur when hands are removed of their position or to the end of one minute when some object has not movement in the washbasin (cloth, soap, etc.).The tap shall not require wash basin distance adjustment.

This shall be assured automatically. Taps shall be automatic, chromed, with sensor and mixer for regulation of the temperature of the water, with valve of retention, lithium filter



TECHNICAL SPECIFICATION	Nº	I-ET-3010.1M-1350-190-P4X-001	REV.	0
	BÚZIOS		SHEET	45 of 57
	TITLE: ACCOMMODATION ARCHITECTURE MATERIALS AND EQUIPMENT SPECIFICATION		NP-2	ESUP

and battery, without cut valves. The same taps shall be used for the galley preparation areas (in wash basins), galley exclusive restroom and for the wash basins located inside hospital and changing rooms, in order to ensure proper hygienic conditions in food preparation and hospital procedures. Other restrooms (men and women), the washing basins taps shall be time delay, and shall be provided for fresh water, only.

All sanitary bowls shall have resistant plastic seats. All urinals shall be provided with photocell devices. All showers and closets shall have handle bars. All restrooms shall have personal hygienic sprayers and be provided with cloth and towel hangers. All Restrooms shall have garbage baskets built in the bench closet. The bench closets, if required, shall be made of plywood covered with melamine plastic sheet (fire retardant). The benches shall be made of granite.

The toilet bowls shall be installed in individual compartments, separated by non combustible partitions. Toilet bowl and showers cabins shall have independent doors at least 0.60m wide, installed at 0.15m above floor level, and fitted with locks” engaged/free” type. Shower cabin partitions shall be provided with doors. Partitions and doors shall be acrylic with aluminum structure or C class panels provided splash resistance material finishing. Showers cabins shall have coaming (except for hospital shower) in order to retain water inside it.

14 STAINLESS STEEL FURNITURE AND ACCESSORIES

14.1 General

All stainless steel furniture shall be AISI 304, except noted. The stainless steel furniture shall be provided and detailed in accordance with the arrangement drawings.

14.2 Characteristics

In general, stainless steel benches shall be constructed with sinks and facilities for hot and fresh water, faucets with spray rinse and flexible connections. All benches in galley preparation areas shall be provided with facilities for cleaning material and gloves.

All faucets shall be chrome plated, bench type (except noted), provided with mixtures for hot and fresh water and be activated by levers for Galley, Mess Room, Laundry, Laboratory, Hospital, as well for external area close to provisions entrance.

All benches shall be provided with shelves and drawers whenever necessary and shall be provided with 75 mm back splash in order to protect the wall against water spray. Furniture foundation shall be detailed in order to achieve specific safe work practices required for offshore personnel to work injury free. Benches shall be provided with devices for cable routing and be suitable for equipment installation. The garbage disposal shall be located under or close to the bench. The garbage disposal shall be stainless steel, with wheels and properly covered, unless otherwise specified.

Galley ware accessories such as spoons, knives, forks and other items required for preparation and cooking shall be stored with proper devices like bars or shelves and shall be easily reached.

Dry provision shelves shall be stainless steel plates where required. Stainless steel trolleys shall be provided in order to minimize back problems caused by handling of heavy loads. Granite top with stainless steel structure shall be provided for bakery area (in accordance with the arrangement drawings).



TECHNICAL SPECIFICATION	Nº	I-ET-3010.1M-1350-190-P4X-001	REV.	0
	BÚZIOS		SHEET	46 of 57
	TITLE: ACCOMMODATION ARCHITECTURE MATERIALS AND EQUIPMENT SPECIFICATION		NP-2	
		ESUP		

The clean material stores located on Living Quarters decks shall be provided with sinks and taps for fresh water for deck cleaning purpose.

15 GALLEY, MESS ROOM AND PROVISION STORE

15.1 General

Galley, mess room and provision store equipment shall be marine industrial type, heavy duty, stainless steel finishing. Quantities and location shall be in accordance with the basic arrangement. A-0 class Rolling Shutter Doors shall be constructed from 0.7mm curved section galvanized steel laths fitted with end locks and bottom rail comprising two steel floats. Hand and automatic operation is required.

The manufacturer shall include in the proposal the list of spare parts (to be stored on board) required for the maintenance of the equipment.

The spare parts list shall be submitted to PETROBRAS approval during the proposal analysis phase. Handling facilities shall be provided for the removal and replacement of provision room.

Refrigerant fluids with HCFC and CFC are not acceptable. Only refrigerant fluids with HFC shall be used. Refrigerating temperatures shall be -2°C to +10°C for refrigerators and -15°C to -24°C for freezers. Refrigerators and Freezers, if required during detailed design phase, in stead of existing frigorific chamber (concept "As New") shall be AISI 304 stainless steel, whenever practicable, remote cooling. Temperature controllers shall be fully programmable to perform all control functions. "Compressor run" / "defrost on" signs and digital indication of temperature shall also be provided. . The supply frequency considered for Freezers and Refrigerators dimensioning shall be fifteen days for 110 people. The refrigerators and freezers shall be remote cooled. Two sets of Air cooled Condenser Units; both including two compressors (one in function and one spare) shall be provided according to manufacturer instructions.

For frigorific chamber refer to I-ET-3010.82-5250-300-PPC-002- HVAC-design Accommodations.

The following Brazilian rules and regulations shall be followed, but not limited to:

- NR 17 Ergonomia (Ergonomics);
- ANVISA RDC 216 – 15/SEP/2004.

15.2 Characteristics

Equipment foundation design shall be in accordance with the manufacturer instructions; however, foundation installation shall be adjusted in order to not extend beyond equipment foot print preventing injuries or discomforts for the users. Foundation details shall be submitted to PETROBRAS approval.

The pan, trays and pots washing area shall be provided and shall be suitable for this activity regarding space, lighting and design, acoustic and thermal comfort.

Each work area in galley shall be detailed in order to locate all the necessary equipment and accessories to its use, providing enough space for preparation activity. Therefore, the group of benches shall be detailed with compatible width, length and height.



The Mess Room equipment location shall be in accordance to the order of each equipment use, avoiding unnecessary crossings. Therefore spice trays, dessert coolers and other equipment (juice cooler, Ice machine, etc.), shall be located in order to allow its use without compromising the comfort of the users. Decorative pictures and panels shall be placed in accordance with Petrobras during the detailed phase.

All food shall be clean and free of any contaminations before being taken to the preparation area.

Two food waste disposals shall be provided as near as possible of preparation and washing area. The volume of garbage generated by meat, fish and salad preparation should be grinded during food preparation. The main purpose of the food waste disposal location is to optimize its use, avoid (or reduce) the noises generated by this equipment during meal time, and reduce unnecessary crossing using garbage disposals inside galley area.

Each preparation area should be equipped with one refrigerator for local food storage.

Drains shall be located in order to guarantee good hygienic conditions.

Note: The disposal of organic material shall be made through a pipe (trash pipeline) directly into the sea.

16 INFIRMARY

16.1 General

The following Brazilian rules and regulations shall be followed, but not limited to:

- NR 17 - Ergonomia (Ergonomics);
- NR 32 – Security and health assistance establishment work;
- NORMAN 01 – CAP.9 – SEÇÃO V – Brazilian Navy Rule;
- ANVISA RDC 50 – 21/Feb/2002.

The hospital ambient shall be provided in accordance with the arrangement drawing.

The minimum useful area for hospital shall include treatment room, hospital room, clinic, waiting room and private bathroom. These areas shall be separated by linings and doors and integrated by glazed panels whenever required.

Hospital shall be provided with two accesses: an internal one, opening to the accommodation corridor and an external one, double leaf, with free access to open deck.

16.2 Characteristics

The Examination and treatment areas should have wash basins for hand washing equipped with time delay taps (electronic type, hot and fresh water) as previously described (refer to sanitary ware item). The external door dimensions shall allow the entrance of stretches without obstacles. The Hospital floor shall not present steps or level differences. The drains shall be located close to wet areas for cleaning purpose.

All hospital furniture and equipment shall be supplied by a company with expertise in the area. Bed mattress and curtains shall be light color, including waiting room and clinic upholstery and should be provided with impermeable and washable material finishing.



TECHNICAL SPECIFICATION	Nº	I-ET-3010.1M-1350-190-P4X-001	REV.	0
	BÚZIOS		SHEET	48 of 57
	TITLE: ACCOMMODATION ARCHITECTURE MATERIALS AND EQUIPMENT SPECIFICATION		NP-2	
		ESUP		

Waste disposals shall be properly covered, stainless steel made and placed in each of the areas. The Hospital garbage shall be stored outside of hospital in order to be removed, due to contamination. This area shall be proper covered and ventilated.

The Utilities store (or expurgation), shall be a space suitable for cleaning, disinfection and storage materials and clothes used in the assistance to the patient and temporary residues storage. It must be provided with area and equipped with sink with rinse spray unit and expurgation sink with discharge valve and sewer piping of 75mm (minimum).

17 GYMNASIUM.

17.1 Gymnasium

Gymnasium equipment specification, quantity and location shall be in accordance with the basic arrangement drawing. The equipment shall be professional type.

The gymnasium equipment shall be located in order to ensure that the minimum areas (in accordance with manufacturer instructions) required to their use as well the comfort of the users. Detailed drawings shall be submitted to PETROBRAS approval.

18 WAREHOUSE AND STORES

Warehouses and stores layout shall be suitable for material, tools and equipment storage in accordance with the arrangement drawing.

Shelves shall be installed inside warehouses in order to optimize the storage of light and heavy parts. The shelves system shall be industrial type, and should be detailed considering the dimension and weight of these pieces. Detailed drawings shall be submitted to PETROBRAS approval.

Electronic parts shall be storage inside refrigerated warehouse. One wardrobe with drawers, shelves and doors shall be provided for this purpose.

Cargo handling devices, as such wheeled cars, shall be foreseen whenever required so.

19 WORKSHOPS AND TOOLSHOP

The workshops shall be "As New" and location maintained as per original design in accordance with arrangement drawings. The equipment conditions shall be evaluated during the detailed design phase; however the following aspects shall be followed;

The workshops design shall be provided with cargo handling devices suitable for its use. The weight and dimension of equipment or parts shall be considered regarding cargo handling sizing. Cargo handling devices shall be provided in order to reduce unnecessary efforts for pieces movement.

The Tool Shop shall be provided with industrial shelves and cabinets proper for tools storage.

The doors width and height shall be compatible with equipment dimension to be moved inside each workshop.

The workshops shall have conditions to provide preventive and scheduled mechanical, electrical, and mechanical services, light machining, and setting of air, electrical, and electronic instruments and shall be defined during detailed design phase.

On 3rd Deck, the existing Warehouse shall be divided in another four compartments: Warehouse Administrative/ Electronic Equipment, Tool shop, and Warehouse. Air conditioning shall be provided for Warehouse Administrative/Electronic Equipments and Tool Shop.

20 MISCELLANEOUS

20.1 Miscellaneous shall be distributed and installed on Accommodations, as described below. If there is any inconsistency between this list and arrangement drawings, the arrangements drawings shall prevail.

20.2 Miscellaneous items, which require wall mounting, like decorative boards, general arrangements, etc. shall be distributed and installed in agreement with PNBV. Safety signs shall be located in accordance with applicable regulations. General arrangement with location of boards and safety signs shall be submitted to PNBV approval. All boards shall have stainless steel or aluminum frames and be protected against damage.

- Boards, tables and publications - boards shall be located in closed areas according to NORMAM 1, chapter 9, section VI.
- DPC (Brazilian Navy Authority) shall be consulted on the exact quantity of boards, tables and publications and their location shall be confirmed in the final stage of detailed design phase.

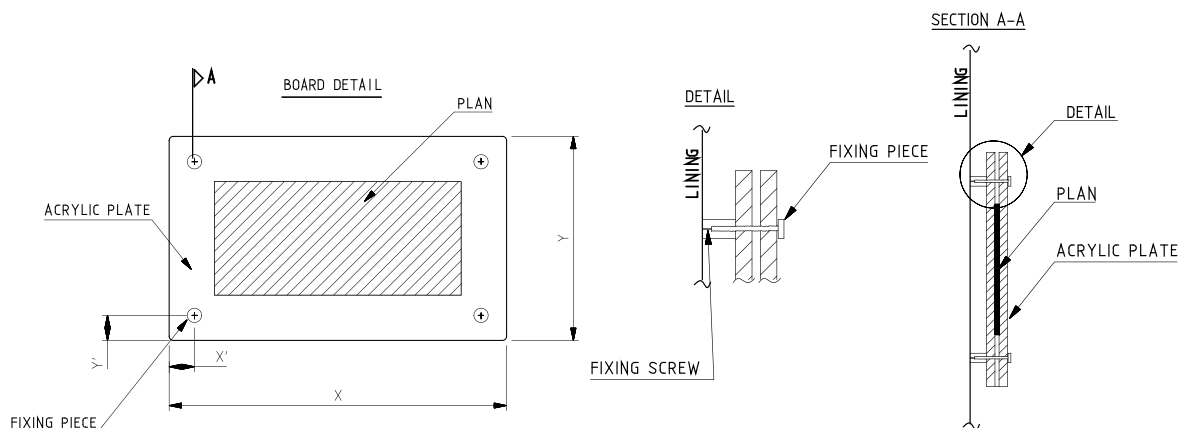

- Magnetic board - Manufacturer standard. Dimensions about 1200(L) x 1000(W):
Quantity – 1 pc;
- Garbage basket – Stainless steel finishing, with cover and pedal:
Quantity – 5 pc;
- Garbage waste disposal bins - shall be provided considering the characteristics of the compartments in which they are installed, using specific containers for paper, plastic and other wastes that are generate. Colors shall be according to “Resolução CONAMA nº 275”;
- Coat hooks (with two hooks), stainless steel or chrome brass:
Quantity – 3 pc;
- Wall Clocks (battery driven, water resistant, stainless steel structure):
Quantity – 1 pc;



TECHNICAL SPECIFICATION	Nº	I-ET-3010.1M-1350-190-P4X-001	REV.	0
BÚZIOS			SHEET	50 of 57
TITLE: ACCOMMODATION ARCHITECTURE MATERIALS AND EQUIPMENT SPECIFICATION			NP-2	
			ESUP	

- Door mats – For humid and saline environment. Rubber sheet, industrial type. Dimensions around 1200 x 600 mm. All entrances to Accommodations from external areas shall have door-mats:
Quantity – 25 pc;
- Paper towel racks fastened next to each sink - Stainless steel, Industrial type:
Quantity – 2 pc;
- Water gallon – The use of water gallons ad its storage on external area shall be analyzed during the detailed design phase regarding contamination risks, temperature and handling.
- Decorative pictures - Wood Frame. Pictures and dimensions shall be defined during detailed design phase. Final choice of the paintings shall be made by PETROBRAS.
Distribution:
 - Collective Rooms - 3 pc each;
 - Offices - 1 pc for each room ;
- Pushing-pin boards - For notes, cork plate with net covering, aluminium frame.
Dimension: 1200 x 1000mm (minimum).
Distribution:
 - TV / Video Room - 1 pc;
 - Mess Room - 1 pc;
 - Quiet Recreation Room - 1 pc;
 - Mechanical Workshop - 1 pc;
 - Instrumentation Workshop - 1 pc;
 - Electric Workshop - 1 pc;
 - Warehouse - 1 pc for each room.
 - Waiting Room - 1 pc;
 - Clinic - 1 pc;
 - Laboratory - 2pc;
 - Laundry – 1pc;
- Magnetic board - Manufacturer standard. Dimension about 1500 x 1000.The magnetic board shall be located on Mess Room, laboratory, CCR, offices and Warehouse Administrative Area.
- White board - Manufacturer standard. Dimension about 1200 x 1000.The white board shall be located on Mess Room, all offices, CCR, workshops and Warehouse Administrative Area.
- Key cabinet – Stainless steel made with glass doors, suitable for 200 keys. The Key boards shall be located on OIM office and Helilounge.
- Garbage disposal (Garbage area) - Shall be plastic made and wheeled (industrial type), industrial type, in the following colours: red (plastics), blue (papers and books from offices),

TECHNICAL SPECIFICATION	Nº I-ET-3010.1M-1350-190-P4X-001	REV. 0		
			BÚZIOS	
			SHEET 51 of 57	
TITLE: ACCOMMODATION ARCHITECTURE MATERIALS AND EQUIPMENT SPECIFICATION		NP-2		
		ESUP		

black (wood), grey (general), brown (food), orange (laboratory), green (glasses), yellow (cans), white (hospital). With cover and handle bars for garbage transportation, capacity (about) 200 litres $\varnothing \cong 600\text{mm}$.

- Ashtray – Stainless steel made, floor type. It shall be installed TV/video room (smoking), 2 pc.
- Garbage disposal for Mess Room - Shall be wheeled and stainless steel made. The model and quantity shall be in accordance with the arrangement drawing.
- Garbage disposal (general) –With facilities to dismantling when necessary. Stainless steel finishing, proper covered. Garbage disposals total quantity for restrooms and changing room shall be in accordance with the Accommodation arrangement drawings.

Distribution:

- Offices - 1 pc for each workstation;
- Warehouse Administrative Area;
- Telecom - 1 pc;
- Mess Room - According to arrangement drawing;
- Quiet Recreation Room- 1 pc for each room;
- Gymnasium - 1 pc;
- TV/Video Room – 1 pc for each room;
- Auditorium -1 pc;
- Helilounge - 1 pc;
- Internet Room - 1 pc;
- C.C.R. - 3 pc;
- Meeting Room - 1 pc for each room;
- Technical Library - 1 pc;
- Radio Room - 1 pc;
- Garbage disposal - Industrial type, wheeled. For warehouses, Tool Shop and Workshops (2 pcs for each room).
- Equipment cabinet - Galvanized steel, Industrial type, with shelves, doors and padlock. Quantity, location and dimension shall be according to workshops arrangement plan, which shall be developed during the detailed design phase.
- EPI cabinet Industrial type- For EPI equipment storage, steel made. Cabinet shall be provided with shelves and doors. Dimension: 1000 (L) x 500 (W) x 1800 (H) mm.
- Coat hooks (twin type), stainless steel. Coat hooks total quantity for restrooms and changing rooms refer to the Accommodation arrangement drawings.

Distribution (minimum):

- Offices (general) - 4 pc;
- Warehouse Administrative Area;
- Mess Room – According to arrangement drawing;



- TV/Video Room- 5pc (for each room);
- Gymnasium - According to arrangement drawing;
- Helilounge - 10 pc;
- Hospital - 10 pc;
- Laundry- 4 pc;
- Laboratory - 6pc;
- Cabins - 1 pc for each person;
- C.C.R.- 10 pc;
- Radio Room - 2pc;
- Meeting Room – according to Accommodation drawing;
- Technical Library - 4 pc;
- Telecom - 2 pc;
- Wall Clocks (battery driven, water resistant, stainless steel structure)
 - Distribution shall be as follows:
 - TV / Video Room - 1 pc for each room;
 - Mess Room - 1 pc;
 - Hospital, treatment room and clinic - 1 pc for each room;
 - Helilounge - 1 pc;
 - Workshops - 1 pc for each room;
 - Offices - 1 pc for each room;
 - Laboratory - 1 pc;
 - Laundry - 1pc;
 - Meeting Room - 1 pc for each room;
 - Video conference room - 1 pc;
 - Technical Library - 1 pc;
- Handrail – Stainless steel .It shall be installed on corridors, stair cases and Mess Room.
- Door mats – For humid and saline environment. Rubber sheets, industrial type, dimension around 1200 x 600 mm. All entrances to the accommodation decks shall have door-mats.
- Identification luminous acrylic plate, with aluminium structure and fastening shall be bolted to the structure. The plate with the unit name shall be installed. A lighting system shall be provided with a minimum illumination level of 100 lux. Letters (1000 mm high) shall be marked with intermittent welding and painted in a black color over a yellow color background. The port of registry name shall be included in the lower part of the F.P.S.O. identification plate located at stern side. The letters shall be 600 mm high. Additional plates with the F.P.S.O. code and the side identification (PS/BB or/and SB/BE) shall be provided at unit sides. The letters shall be 1000 mm high. Marking required by authorities shall be

accordingly displayed. Marine norm, chapter IX, section 3, item 0913 (Visual Signalization) shall be followed.

- Screen curtains for Welding area (if required during detailed design), shall be resistant vinyl, with proper characteristics of resistance for this type of ambient. These curtains shall be fixed by means of rings in pipe structure.

20.3 *Nautical instruments shall be provided in accordance with the table below:*

ITEM	QTY	DESCRIPTION	LOCATION
01	05	Aneroid barometer	Helilounge, C.C.R, Telecom and Radio Room.
02	03	Display for wind speed and direction indicator	Helilounge, C.C.R, Telecom and Radio Room.
03	06	Pendulum clinometers (Heel/Trim)	Helilounge C.C.R, Telecom and Radio Room.
04	01	Radio Room Clock	Radio Room
05	01	Portable fog horn (mechanical type)	See note 1.
06	02	Binocular (7 x 50) with wood box.	See note 1.
07	02	Anemometer	See note 1.
08	02	Clinometers (electric high precision type), one for heel and one for trim, +/- 10° range with digital display.	See note 1.
09	01	Standard compass	See note 1.
10	01	DGPS system	See note 1.
11	01	Current meter	See note 1.
12	01	Main fog horn	See note 1.
13	04	Thermometer for air	See note 1.
14	01	Thermometer for water	See note 1.
15	02	Clinometers (gravity type)	See note 1.

Note 1: Location will be informed by PETROBRAS during the detailed design phase.

- Signaling devices shall be provided as follows:
 - Three (3) units - Day signal (black ball);
 - One (1) unit - Day signal (black diamond);
 - Twelve (12) units - Parachute flare (emergency signal);
 - One (1) unit - Container of plastic for parachute flare;
 - One (1) set - A full set of Signal flags listed in the international code book;
 - Three (3) - National flags;



TECHNICAL SPECIFICATION	Nº	I-ET-3010.1M-1350-190-P4X-001	REV.	0
BÚZIOS			SHEET	54 of 57
TITLE: ACCOMMODATION ARCHITECTURE MATERIALS AND EQUIPMENT SPECIFICATION			NP-2	
			ESUP	

-One (1) unit - Bell, 14 inch inside diameter;

Notes:

- 1- Emergency signal material shall be in accordance with the requirements of authorities.
- 2- All flags shall be of flag cloth.
- 3- The bell shall be of metal and engraved with the name of the unit and the construction year.
- 4- The bell shall comply with the Annex III of the COLREG Requirements.
 - Lifting accessories shall be provided as follows:
 - Wire ropes for container lifting – 2 set;
 - Set of steel basket with wire ropes and shackles for general purpose – 1 set;
 - Personnel transfer net – 2 pcs;

21 ERGONOMIC ASPECTS

21.1 General

- 21.1.1 The safe work practices required for personnel safe work in the offshore environment shall be evaluated and validated by PNBV during the detailed design phase. It includes proper lifting devices and techniques, posture relief methods, use of ergonomic principles for lifting and moving materials, equipment or pieces of equipment, inside industrial rooms, service rooms, and work rooms as well in open areas.
- 21.1.2 Workstations shall be designed according to the work characteristics, the level of mechanization and automation, and shall use “state of the art” solutions in design, materials and technologies for the offshore industries.
- 21.1.3 Rooms’ design shall be based on task analyses of functions, controls and displays shall be located in a logical way with respect to frequency of use and importance for safe operation; the movement of a control device should be consistent with the effect in direction and magnitude. They shall be clearly marked in Portuguese language. Displays and controls shall be designed in accordance with acknowledged ergonomic principles and in order to allow the operator to carry out his tasks in a safe way. The variations of display types shall be minimized. Screens, panels and lighting fixtures shall have a location that provides a satisfactory view in a normal working posture. It shall be easy to adjust the height and angle of computer screens and keyboards, as well as their distance to the operator. Total system overviews should be available from the displays, giving the operator opportunities to watch global process performance.
- 21.1.4 The anthropometric dimensions should be taken into account in architecture project and other areas of UEP for sizes and heights of work surface in the control rooms, working rooms and offices.
- 21.1.5 The base of the furniture must be detailed in order to reach the specific practices required for safe work offshore staff to work free of injury.



TECHNICAL SPECIFICATION	Nº I-ET-3010.1M-1350-190-P4X-001	REV. 0
BÚZIOS		SHEET 55 of 57
TITLE: ACCOMMODATION ARCHITECTURE MATERIALS AND EQUIPMENT SPECIFICATION		NP-2
		ESUP

21.1.6 The equipment specifications and location, speakers, screens and TV shall be provided in such a way to guarantee an efficient and pleasant result, and supplied by a specialized company.

21.1.7 The following issues shall be implemented, regarding work chairs, lighting, thermal and acoustic solutions:

21.2 Work chairs

The design of a working chair that fits different sizes of people is a design problem that shall receive special attention during the detailed engineering design phase. Most work chair designs try to accommodate people of different sizes and shapes with a series of mechanical adjustments. People are more likely to get proper support from a chair that requires only minor adjustments to fine-tune the fit. Chairs model shall be suitable to be used by people with different shape and weight. A person sitting in a properly sized chair starts with a fit that is fairly close to perfect. Adjustments for seat height, lumbar height and depth, arm height and width, and tilt tension enable the sitter to fine-tune chair dimensions and performance to personal preferences. The material of the seat and backrest shall be able to automatically conform to individual body contours. The chairs must have adequate casters to the type of floor of each room. For specification, refer to item 10.0.

21.3 Lighting

21.3.1 Bright lights shining on the display screen "wash out" images, making it harder to clearly see the information. Straining to view objects on the screen can lead to eye fatigue. Proper placement of lighting and selecting the right level of illumination can enhance the ability to see monitor images. For example, if lighting is excessive or causes glare on the monitor screen, the user may develop eyestrain or headaches, and may have to work in awkward postures to view the screen. Ideally, the lighting environment should be conducive to both reading of hard copy and screen based work. Use light, matte colors and finishes on walls and ceilings and workstation, to prevent glare and the color shall be light (off white is recommended to better the contrast and visualization of the task). The area close to the screen shall have differentiated circuits and shall be dimmerized.

21.3.2 Quantity and quality of lighting are both important. Lower, rather than higher, powered lamps shall be provided for task lights, since excessive levels of task lighting can put strain on the eye muscles in switching between brightly lit paper copy and a self-illuminated screen. For computer work, use well-distributed diffuse light. The advantage of diffuse lighting is that there are fewer hot spots (or glare surfaces) in the visual field, and the contrasts created by the shape of objects tend to be softer.

21.3.3 Placing the monitor beside window(s) as well as a window directly behind the monitor or behind the user will cause glares. If not possible, due to the arrangement plan, the use of blinds or drapes to control the light shall be provided. The most important aspect of lighting shall be the reduction of glare and bright reflections from the screen of workstations (the task light should provide light from the left and right), as well as to provide a pleasant atmosphere.

21.3.4 The quality of the illumination must consider aspects of: safety in handling and reading gradation of glassware, cognitive aspects of reading and writing

information and the visual comfort in reading monitors and electronic panels. Therefore it is required that the illumination equipment have anti-glare apparatus.

- 21.3.5 Wall lamps in height to eye level of the operators, should always have reflectors so that the angle incidence of the luminous flux does not produce glare.
- 21.3.6 A mixture of fluorescent, incandescent light or lamp with a color temperature equivalent shall be provided to offices, control rooms and working rooms.
- 21.3.7 The possible solutions should be implemented, whenever required so:
- Provide light diffusers so that desk tasks (writing, reading papers) can be performed while limiting direct brightness on the computer screen.
 - Provide supplemental task/desk lighting to adequately illuminate writing and reading tasks while limiting brightness around monitors. For LCD monitors higher levels of light are usually needed for viewing tasks.

21.4 Thermal comfort

Comfort at work is an important issue. The best temperature for the workplace is the temperature most people find comfortable without particularly discomforting the few people who have unusual temperature preferences. Users may experience discomfort from poorly designed or malfunctioning ventilation systems, for example, air conditioners that directly "dump" air on users. To avoid this, desks, chairs, and other office furniture shall not be placed directly under air conditioning vents unless the vents are designed to redirect the air flow away from these areas.

21.5 Acoustic Comfort

Acoustic design shall be applied to accommodate equipment layout, general comfort, workability, and ergonomics in order to achieve the efficient acoustic performance of the room. The optimized acoustic environment shall be achieved with low-noise air conditioning systems, sound insulating windows and doors, floor coverings with sound dampening properties and lastly treatment of the wall and ceiling panels.

The Noise Control Report (and Noise control analysis, required during detailed design phase) shall be a guide of acoustic solutions to be applied. The Insulation arrangement drawing shall represent a picture of all required insulation.

For Acoustic Comfort requirements, refer to I-ET-3010.1M-1200-300-P4X-002 – NOISE CONTROL REQUIREMENTS FOR ACCOMMODATION.

21.6 Lifting and Transportation

The following requirements shall be observed and implemented:

- Transportation ways where trolleys and carts are used shall not contain steps and thresholds.
- Lifting and transportation gear where lifting or transportation of more than 25kg is required.



TECHNICAL SPECIFICATION	Nº I-ET-3010.1M-1350-190-P4X-001	REV. 0
BÚZIOS		SHEET 57 of 57
TITLE: ACCOMMODATION ARCHITECTURE MATERIALS AND EQUIPMENT SPECIFICATION		NP-2
		ESUP

- Trolleys, transportation tables and similar means of transportation should be easily maneuverable and have a low rolling resistance. Minimum two of the wheels shall be lockable.
- Units in everyday use shall not be stored above shoulder height (1500 mm) or below 900 mm.
- Permanent arrangements (e.g. monorails, pad eyes) shall be installed for material handling of equipment/objects heavier than 200kg.
- In addition, when designing for permanent or temporary lifting equipment, the estimated frequency of the lifting operations shall also be taken into account. For frequent/routine lifting operations, permanent equipment shall be installed.
- Manual lifting of gas bottles shall be avoided. Cupboards for gas bottles shall be of a non-threshold type.
- Doors (L x H) shall be sized in order to assure the entrance of equipment and stretcher without obstacles. Removable panels shall be provided and installed if the doors alone do not provide enough room for cargo handling. In this case, doors and removable panel location shall be carefully studied in order to guarantee the access, entrance and maintenance of all equipment parts.
- For more recommendations regarding Lifting and Transportation, refer to I-ET-3010.1M-1350-196-P4X-002 – ERGONOMIC REQUIREMENTS FOR HULL.