	<b>TECHNICAL SPECIFICATION</b>	No. <b>I-ET-3010.00-1200-431-P4X-001</b>	
	CLIENT:	SRGE	SHEET 1 of 57
	PROJECT:	-	
	ÁREA:	-	
	TITLE:	<b>THERMAL INSULATION FOR MARITIME INSTALLATIONS</b>	ESUP INTERNAL

MICROSOFT WORD / V. 2016 / I-ET-3010.00-1200-431-P4X-001\_H.DOCX

## INDEX OF REVISIONS

REV.	DESCRIPTION AND/OR REVISED SHEETS
0	ORIGINAL ISSUE
A	PERSONNEL PROTECTION ITEMS 4.3.2 AND 4.5.3 REVISED
B	GENERAL REVISION
C	ITEM 4.1.4; 5.1.1.1.; 5.2.1; 6.1.5; 6.1.6; 7.2.8; 9.5.1 AND FIGURE A-5 REVISED ACCORDING CLARIFICATION NOTICE DUE BIDDERS QUESTIONS
D	ITEM 6.1.6; AND 6.2 REVISED ACCORDING CLARIFICATION NOTICE DUE BIDDERS QUESTIONS
E	GENERAL REVISION ACCORDING TO THE REQUIREMENTS OF IOGP S-738
F	REVISED WHERE INDICATED
G	REVISED WHERE INDICATED
H	GENERAL REVISION ADDING TO THE TEXT ALL IOGP-614 ITEMS

	REV. 0	REV. A	REV. B	REV. C	REV. D	REV. E	REV. F	REV. G	REV. H
DATE	AUG/08/18	FEB/18/19	JUL/03/20	SEP/30/20	OUT/14/20	FEV/10/21	ABR/20/21	DEC/07/22	ABR/30/24
DESIGN	ESUP	ESUP	ESUP	EEA	EEA	EEA	EEA	EEA	EEA
EXECUTION	MARCHON	MARCHON	MMARROIG	CJH4	CJH4	CJH4	CJH4	HXG3	CJH4
CHECK	MARIANO	TMCAMPOS	FRAGOMENI	CJMI	CJV5	SXED	QM66	CJH4	CSM0
APPROVAL	JUVENTINO	JUVENTINO	GONZALEZ	U32N	U32N	U32N	U32N	U32N	U32N

THE INFORMATION CONTAINED IN THIS DOCUMENT IS PETROBRAS PROPERTY AND MAY NOT BE USED FOR PURPOSES OTHER THAN THOSE SPECIFICALLY INDICATED HEREIN

THIS FORM IS PART OF PETROBRAS N-381 REV. M



PETROBRAS

TECHNICAL SPECIFICATION

No. I-ET-3010.00-1200-431-P4X-001

REV: H

AREA

-

SHEET:

2 of 57

TITLE:

THERMAL INSULATION FOR MARITIME INSTALLATIONS

ESUP

INTERNAL

SUMMARY

**OBJECTIVE ..... 3**

**SECTION I – COMPLEMENTARY REQUIREMENTS TO IOGP S-738 AND NORSOK M-004..... 4**

**1 SCOPE ..... 4**

**2 NORMATIVE REFERENCES..... 5**

**3 TERMS AND DEFINITIONS..... 8**

**4 SYMBOLS AND ABBREVIATIONS..... 11**

**5 QUALIFICATION REQUIREMENTS ..... 11**

**6 MATERIALS..... 14**

**7 DESIGN ENGINEERING ..... 19**

**8 INSTALLATION AND INSPECTION..... 23**

**ANNEX A (INFORMATIVE) KEY DATA FOR INSULATION ..... 28**

**ANNEX B (NORMATIVE) GENERAL ..... 29**

**ANNEX C (INFORMATIVE) TEST PIECE FOR SITE TEST ..... 30**

**ANNEX D (NORMATIVE) MATERIAL DATA SHEETS (MDSS) ..... 31**


**ANNEX E (INFORMATIVE) EXAMPLE INSULATION CHECKLIST ..... 45**

**APPENDIX A – FIGURES..... 47**

**APPENDIX B – REFERENCE TABLES..... 55**

**SECTION II – IOGP S-738L INFORMATION REQUIREMENTS FOR INSULATION FOR PIPING AND EQUIPMENT..... 57**

**SECTION III – IOGP S-738Q QUALITY REQUIREMENTS FOR INSULATION FOR PIPING AND EQUIPMENT..... 57**

	<b>TECHNICAL SPECIFICATION</b>	No. I-ET-3010.00-1200-431-P4X-001	REV: H
	AREA: -	SHEET: 3 of 57	
	TITLE:	<b>THERMAL INSULATION FOR MARITIME INSTALLATIONS</b>	
		ESUP	
		INTERNAL	

## OBJECTIVE

This Specification establishes the technical requirements for the execution of external thermal insulation of surfaces of equipment, structures, and piping to be supplied to PETROBRAS FPSOs.

This specification complements:


NORSOK M-004,

IOGP S-738 and its amendments (IOGP S-738L and IOGP S-738Q)

This technical specification is written as an overlay to IOGP S-738 (version 1.0, December 2020), matching the same numbers of section and subsections, which are reproduced in the following items. If a section (or subsection) of IOGP S-738 needs a modification, this specific section is identified inside a box with: Add (add to section or add new section), Replace (part of or entire section) or Delete. Otherwise, if no supplementary or modification is required, the section (or subsection) of IOGP S-738 specification or NORSOK M-004 is mandatory

In addition to the requirements of this technical specification, SELLER shall follow all the requirements of the Exhibit I (Scope of Work), as well as Exhibit III (Directives for Engineering Execution), Exhibit IV (Directives for Construction and Assembly), Exhibit V (Directives for Procurement), Exhibit VI (Directives for Planning and Control), Exhibit VII (Directives for Quality Management System) and Exhibit VIII (Directives for Commissioning Process).

The requirements herein listed are applicable to all players performing such related activities within the scope of this unit, including SELLERS, manufacturer, main SELLER, subcontractors, suppliers, sub suppliers, integrators, constructors, and all technical personnel involved. Within the scope of this document, they are all referred to as being a SELLER.

	<b>TECHNICAL SPECIFICATION</b> No. I-ET-3010.00-1200-431-P4X-001	REV: H
	AREA -	SHEET: 4 of 57
	TITLE: <b>THERMAL INSULATION FOR MARITIME INSTALLATIONS</b>	ESUP INTERNAL

## SECTION I – COMPLEMENTARY REQUIREMENTS TO IOGP S-738 AND NORSOK M-004

### 1 SCOPE

#### Replace section with

This specification covers the minimum requirements for the procurement of insulation for equipment and packages for offshore/onshore installations. Insulation of pipes, equipment, vessels, tanks, valves, flanges and instrument tubing are covered. Thermal insulation, personnel protection, fire protection and acoustic protection for a normal operation temperature range of -200 °C to 800 °C is covered by this specification.


The scope of this specification includes the following:

- selection of insulation materials and cladding;
- material data sheet for insulation materials and cladding;
- requirement for calculation of thickness for thermal and personnel protection;
- requirement for qualification of insulation system for fire and acoustic insulation;
- design requirement for proper installation of insulation;
- requirement for qualification of insulation installation personnel and inspection personnel;
- installation requirements;
- inspection requirements, including inspection checklist.

In all above areas, there is a high focus on reduced risk for corrosion under insulation.

The scope of this specification excludes the following:

- insulation of subsea equipment and piping (flowline risers);
- insulation of burners, furnaces or similar;
- insulation of buildings and civil structures;
- insulated ducting for heating, ventilation and air condition (HVAC);
- insulation of buried equipment and piping systems;
- insulation of flowlines and pipelines;
- pre-insulated manufactured tubing as a finished product;
- pre-insulated piping;
- spray-on passive fire protection (PFP);
- passive fire protection of structure, including piping and equipment supports with concrete based system;
- enclosures (thermal and acoustic);
- internal insulation (e.g. any kind of insulating refractory lining);
- pipe penetrations in bulkhead and deck;
- loose fill insulation;
- sprayed and in-situ formed foam;

	<b>TECHNICAL SPECIFICATION</b>	No. I-ET-3010.00-1200-431-P4X-001	REV: H
	AREA: -	SHEET: 5 of 57	
	TITLE:	<b>THERMAL INSULATION FOR MARITIME INSTALLATIONS</b>	

INTERNAL

- onshore field fabricated atmospheric storage tanks;
- explosion testing in connection to fire testing of insulation systems.

## 2 NORMATIVE REFERENCES

### Delete from section

ASTM E662, Standard Test Method for Specific Optical Density of Smoke Generated by Solid Materials

DNVGL-CP-0165, Cable and pipe penetrations

IACS UR S14, Testing procedures for watertight compartments

IMO 2010, FTP Code Part 1 Non combustibility test

IMO 2010, FTP Code Part 2 Smoke and toxicity test

IMO 2010, FTP Code Part 3 Test for "A", "B", and "F" Class Divisions

IMO 2010, FTP Code Part 5 Test for surface flammability

ISO 9865, Textiles – Determination of water repellency of fabrics by the Bundesmann rain shower test

NES713, Toxicity Test Apparatus

NORSOK C-002, Architectural components and equipment

NORSOK M-001, Material selection

NORSOK M-501, Surface preparation and protective coating

NORSOK S-001, Technical Safety

NORSOK S-002, Working environment

Marine Equipment Directive, Directive no.2014/90/EU

PSA, The Facilities Regulations (Innretningsforskriften)

PSA, Technical and Operational Regulations (Teknisk og operasjonell forskrift for landanlegg)

### Add to section

ASTM A240M, Standard Specification For Chromium and Chromium-Nickel Stainless Steel Plate, Sheet, and Strip for Pressure Vessels and for General Applications

ASTM B209, Standard Specification for Aluminium and Aluminium-Alloy Sheet and Plate

ASTM C302, Standard Test Method for Density and Dimensions of Preformed Pipe-Covering-Type Thermal Insulation


ASTM C303, Standard Test Method for Dimensions and Density of Preformed Block and Board-Type Thermal Insulation


ASTM C533, Standard Specification for Calcium Silicate Block and Pipe Thermal Insulation


ASTM C534 / C534M, Standard Specification for Preformed Flexible Elastomeric Cellular Thermal Insulation in Sheet and Tubular Form

ASTM C547, Standard Specification for Mineral Fiber Pipe Insulation

ASTM C552, Standard Specification for Cellular Glass Thermal Insulation

	<b>TECHNICAL SPECIFICATION</b>	No. I-ET-3010.00-1200-431-P4X-001	REV: H
	AREA: -	SHEET: 6 of 57	
	TITLE:	<b>THERMAL INSULATION FOR MARITIME INSTALLATIONS</b>	
INTERNAL			
<p>ASTM C553, Standard Specification for Mineral Fiber Blanket Thermal Insulation for Commercial and Industrial Applications</p> <p>ASTM C591, Standard Specification for Unfaced Preformed Rigid Cellular Polyisocyanurate Thermal Insulation</p> <p>ASTM C592, Standard Specification for Mineral Fiber Blanket Insulation and Blanket-Type Pipe Insulation (Metal-Mesh Covered) (Industrial Type)</p> <p>ASTM C610, Standard Specification for Molded Expanded Perlite Block and Pipe Thermal Insulation</p> <p>ASTM C612, Standard Specification for Mineral Fiber Block and Board Thermal Insulation</p> <p>ASTM C680, Standard Practice for Estimate of the Heat Gain or Loss and the Surface Temperatures of Insulated Flat, Cylindrical, and Spherical Systems by Use of Computer Programs</p> <p>ASTM C795, Standard Specification for Thermal Insulation for Use in Contact with Austenitic Stainless Steel</p> <p>ASTM C892, Standard Specification for High-Temperature Fiber Blanket Thermal Insulation</p> <p>ASTM C1729, Standard Specification for Aluminum Jacketing for Insulation</p> <p>ASTM C1767, Standard Specification for Stainless Steel Jacketing for Insulation</p> <p>ASTM D412, Standard Test Methods for Vulcanized Rubber and Thermoplastics Elastomers — Tension</p> <p>ASTM D624, Standard Test Method for Tear Strength of Conventional Vulcanized Rubber and Thermoplastic Elastomers</p> <p>ASTM D751, Standard Test Methods for Coated Fabrics</p> <p>ASTM D790, Standard Test Methods for Flexural Properties of Unreinforced and Reinforced Plastics and Electrical Insulating Materials</p> <p>ASTM D1622, Standard test Method for Apparent Density of Rigid Cellular Plastics</p> <p>ASTM D2583, Standard Test Method for Indentation Hardness of Rigid Plastics by Means of a Barcol Impressor</p> <p>ASTM D3039, Standard test Method for Tensile Properties of Polymer Matrix Composite Materials</p> <p>ASTM E84, Standard Test Method for Surface Burning Characteristics of Building Materials</p> <p>ASTM E96, Standard Test Methods for Water Vapor Transmission of Materials</p> <p>ASTM E136, Standard Test Method for Assessing Combustibility of Materials Using a Vertical Tube Furnace at 750 °C</p> <p>ASTM E228, Standard Test Method for Linear Thermal Expansion of Solid Materials With a Push-Rod Dilatometer</p> <p>EN 485, Aluminium and aluminium alloys - Sheet, strip and plate</p> <p>EN 14306, Thermal insulation products for building equipment and industrial installations - Factory made calcium silicate (CS) products - Specification</p> <p>EN 14308, Thermal insulation products for building equipment and industrial installations - Factory made rigid polyurethane foam (PUR) and polyisocyanurate foam (PIR) products - Specification</p> <p>EN 15501, Thermal insulation products for building equipment and industrial installations - Factory made expanded perlite (EP) and exfoliated vermiculite (EV) products - Specification</p> <p>EN 10088-2, Stainless steels - Part 2: Technical delivery conditions for sheet/plate and strip of corrosion resisting steels for general purposes</p>			

	<b>TECHNICAL SPECIFICATION</b>	No. I-ET-3010.00-1200-431-P4X-001	REV: H
	AREA: -	SHEET: 7 of 57	
	TITLE:	<b>THERMAL INSULATION FOR MARITIME INSTALLATIONS</b>	
EAD 040643-00-1201, Fiber reinforced silica aerogel thermal insulation IOGP S-715, Supplementary Specification to Norsok M-501 Coating and Painting for Offshore, Marine Coastal and Subsea Environments ISO 34, Rubber, vulcanized or thermoplastics — Determination of tear strength ISO 6361, Wrought aluminium and aluminium alloys — Sheets, strips and plates ISO 9223, Corrosion of metals and alloys — Corrosivity of atmospheres — Classification, determination and estimation ISO 12623, Thermal insulating products for building equipment and industrial installations — Determination of short-term water absorption by partial immersion of preformed pipe insulation ISO 29767, Thermal insulating products for building equipment and industrial installations — Determination of short-term water absorption by partial immersion of performed pipe insulation UL1709, Standard for Rapid Rise Fire Tests of Protection Materials for Structural Steel			
<p><u>Add to Section</u></p> <p>API RP 583-Corrosion Under Insulation and Fireproofing          CINI Manual -Committee Industrial Insulation Standards          ISO 12944-2 -Paints and varnishes - Corrosion protection of steel structures by protective paint systems. Part 2: Classification of environments          EN 14304 -Thermal insulation products for building equipment and industrial installations - Factory made flexible elastomeric foam (FEF) products - Specification          EN 14707 -Thermal insulating products for building equipment and industrial installations - Determination of maximum service temperature for preformed pipe insulation</p> <p><u>Delete from Section</u></p> <p>IOGP S-715 -Supplementary Specification to Norsok M-501 Coating and Painting for Offshore, Marine Coastal and Subsea Environments</p>			
<p><u>Add new Section</u></p> <p><b>2.2 CLASSIFICATION SOCIETY</b></p> <p>SELLER shall perform the work in accordance with the requirements of the Classification Society.</p> <p>SELLER is responsible to submit to the Classification Society the documentation in compliance with stated Rules.</p>			
<p><u>Add new Section</u></p> <p><b>2.3 Government Regulation</b></p> <p>NR-12 - Brazilian Regulatory Standard – Safety in the Work of Machinery and Equipment</p>			

	<b>TECHNICAL SPECIFICATION</b>	No. I-ET-3010.00-1200-431-P4X-001	REV: H
	AREA: -	SHEET: 8 of 57	
	TITLE:	<b>THERMAL INSULATION FOR MARITIME INSTALLATIONS</b>	

NR-13 - Brazilian Regulatory Standard - Boilers, Pressure Vessels, Pipes and Metallic Storage Tanks

NR-26 - Brazilian Regulatory Standard - Safety Signaling

NR-37 - Brazilian Regulatory Standard - Safety and Health in Petroleum Platforms

Brazilian Government regulations and Classification Society Rules are mandatory and shall prevail, if more stringent, over the requirements of this specification and other references herein. In case of conflict, SELLER shall submit an issue to BUYER's clarification.

Add new Section

## 2.4 Reference Documents

DR-ENGP-I-1.15 COLOR CODING

DR-ENGP-M-I-1.3 SAFETY ENGINEERING

I-ET-3010.00-1200-956-P4X-002 GENERAL PAINTING

I-ET-3010.00-1200-956-P4X-003 THERMAL SPRAY COATING APPLICATION OF ALUMINUM

I-ET-3010.00-1200-955-P4X-001 WELDING

I-ET-3010.00-1200-940-P4X-002 GENERAL TECHNICAL TERMS

I-ET-3010.00-1200-970-P4X-003 REQUIREMENTS FOR PERSONNEL QUALIFICATION AND CERTIFICATION

I-ET-3010.00-1200-970-P4X-013 - COMPLIANCE WITH NR-13 AND SPIE REQUIREMENTS

Add new Section


## 2.5 Conflicting Requirements

In case of conflicting requirements between this technical specification and the referred applicable standards, the most stringent shall prevail. In case of conflicting information between this specification and other specific BUYER's document, a formal technical query shall be issued to BUYER, seeking clarification.

## 3 TERMS AND DEFINITIONS

Add to Section

Terms and definitions are also established in the latest revision of I-ET-3010.00-1200-940-P4X-002 - GENERAL TECHNICAL TERMS.

	<b>TECHNICAL SPECIFICATION</b>	No. I-ET-3010.00-1200-431-P4X-001	REV: H
	AREA: -	SHEET: 9 of 57	
	TITLE:	<b>THERMAL INSULATION FOR MARITIME INSTALLATIONS</b>	
		ESUP INTERNAL	

### 3.5 temperature definitions

Add after second sentence

Minimum operating temperature: minimum temperature including plant operation at unstable condition. Unstable condition includes start-up/ shutdown, control requirements and process upsets

Replace last sentence with

Material selection: **maximum operating temperature, T<sub>m</sub>**, shall be used for insulation material selection for systems above ambient and **minimum operation temperature, T<sub>l</sub>**, for systems below ambient.

The ambient temperature shall be used for the cladding selection. The temperature on the outer layer of the insulation material shall be calculated according to section 7.2.

### 3.10 insulation class 3: personnel protection

Replace definition with

Protection of personnel from hot and cold surfaces to avoid burns and frostbite.

### 3.13 insulation class 6, 7, 8 and D: acoustic insulation

Replace definition with

Acoustic insulation is specified in order to ensure that noise emission from piping, valves, flanges and equipment meets the area noise requirements for the working environment. The definition of the classes of acoustic insulation is as given in ISO 15665, Clause 4 for class 6, 7 and 8 and as given in Annex F for class D. This standard specifies the minimum insertion loss for each class related to the diameter of the pipe on which it is to be applied.

#### **Class 6**

Minimum insertion loss shall be in accordance with the definition given in ISO 15665 for class A. Valves and flanges shall be insulated when and as required by Company.

#### **Class 7**


Minimum insertion loss shall be in accordance with the definition given in ISO 15665 for class B. Flanges to be insulated. Valves to be insulated when and as required by Company.

#### **Class 8**

Minimum insertion loss shall be in accordance with the definition given in ISO 15665 for class C. Valves and flanges shall be insulated.

#### **Class D**

Minimum insertion loss shall be in accordance with the definition given in annex F for class D. Valves and flanges shall be insulated.

	<b>TECHNICAL SPECIFICATION</b>	No. I-ET-3010.00-1200-431-P4X-001	REV: H
	AREA: -	SHEET: 10 of 57	
	TITLE:	<b>THERMAL INSULATION FOR MARITIME INSTALLATIONS</b>	
		ESUP	
		INTERNAL	

Add new term

**3.15  
blanket**

Flexible fibrous insulation product supplied rolled or flat and which may be faced or enclosed.

Note to entry 1: Also known as mat.

Add new term

**3.16  
boxes**

Insulation enclosed in metal cladding in two or more parts and secured by ex-center locks to be used on flanges, valves, instruments, small equipment, etc. for quick removal and re-installation of the insulation.

Note to entry 1: Also known as enclosure in ISO 15665.

Add new term

**3.17  
cladding**

Rigid, semi rigid or flexible frequent pre-formed material that provides mechanical and/or environmental protection to insulation.

Note to entry 1: Also known as jacketing.

Add new term

**3.18  
cryogenic temperature**

Temperature between -100 °C and -200 °C.

Add new term

**3.19  
insulating jacket**

Flexible assembly of insulation material totally enclosed in fabric that is designed to fit individual items forms.

Note to entry 1: Also known as mattress and as insulation blanket in North America.

Add new term


**3.20  
scrim**

Reinforcing mesh that is included within the thickness of the material. Scrim (cloths) provides tension reinforcement and puncture resistance.

Add new term

**3.21  
non-contact insulation system**

Insulation system with no direct contact between the surface of the pipe/equipment and the insulation material.

	<b>TECHNICAL SPECIFICATION</b>	No. I-ET-3010.00-1200-431-P4X-001	REV: H
	AREA	-	
	TITLE:	<b>THERMAL INSULATION FOR MARITIME INSTALLATIONS</b>	
			SHEET: 11 of 57
			ESUP
			INTERNAL

Add new term

### 3.22

#### insulating coating

Coating that reduces the heat flux of a metal surface and that is used for personnel protection to avoid burns. Insulating coating does not necessarily provide corrosion protection.

## 4 SYMBOLS AND ABBREVIATIONS

Add to section

CS	Calcium Silicate
CSPE	Chlorosulphonated Polyethylene
EP	Expanded Perlite
EPDM	Ethylene Propylene Diene Monomer
FEM	Flexible Elastomeric Membrane
GA	General Arrangement
MDS	Material Data Sheet
NCTI	Netherlands Centre for Technical Insulation
NIA	National Insulation Association (US)
PIR	Polyisocyanurate

## 5 QUALIFICATION REQUIREMENTS

### 5.1 Qualification of personnel

Replace section 5.1.1 title with

#### 5.1.1 Qualification of insulation system installation personnel

Replace first paragraph of IOGP and NORSOK with


Personnel installing insulation and cladding shall be individually qualified by a certified organization as specified in I-ET-3010.00-1200-970-P4X-003 -REQUIREMENTS FOR PERSONNEL QUALIFICATION AND CERTIFICATION, the insulation material manufacturer, the non-metallic cladding manufacturer or the insulation SELLER. If personnel are qualified by insulation materials manufacturer, non-metallic cladding manufacturer or insulation contractor, a qualification procedure shall be established. The qualification procedure shall cover the evaluation of the personnel competences in theoretical and practical aspects.

Delete second paragraph

Delete third paragraph

Replace fourth paragraph with

The theoretical part of the qualification shall include:

	<b>TECHNICAL SPECIFICATION</b> No. I-ET-3010.00-1200-431-P4X-001	REV: H
	AREA: -	SHEET: 12 of 57
	TITLE: <b>THERMAL INSULATION FOR MARITIME INSTALLATIONS</b>	ESUP INTERNAL

- knowledge of health and safety hazard including waste handling;
- use of protection equipment;
- insulation materials;
- cladding material;
- application of insulation materials;
- application of cladding;
- surface requirements of insulation systems ;
- prevention of ingress of moisture in the insulation system;
- drainage to avoid accumulation of trapped water in the insulation system.

Delete fifth paragraph

Replace sixth paragraph with

The practical part of the qualification shall be performed in accordance with the sections of the Insulation Procedure Specification (IPS) related to the equipment/packages to be insulated.

Delete seventh paragraph

Replace first sentence of eighth paragraph with

The theoretical and practical training and testing shall be documented.

Delete second sentence of eighth paragraph

**5.1.2 Qualification of supervisors, foremen and QC personnel**

Replace first paragraph of IOGP and NORSOK with

Personnel carrying out inspection or verification shall be as specified in I-ET-3010.00-1200-970-P4X-003 - REQUIREMENTS FOR PERSONNEL QUALIFICATION AND CERTIFICATION.

Replace second paragraph with

Supervisors and foremen shall have documented three years' experience with insulation work corresponding to the work described in this specification.

Replace third paragraph with

QC and supervision personnel shall be familiar with the requirements of this specification.


**5.2 Qualification of insulation system**

In first sentence, delete "when required Type Approved/Certified"

In second list item, add after "Class 6,7 and 8"

and D

Delete third list item

	<b>TECHNICAL SPECIFICATION</b>	No. I-ET-3010.00-1200-431-P4X-001	REV: H
	AREA	-	
	TITLE:	<b>THERMAL INSULATION FOR MARITIME INSTALLATIONS</b>	
		SHEET:	13 of 57
			ESUP
			INTERNAL

### 5.2.1 Class 5 and F Insulation

In first paragraph, replace first sentence with

Fire insulation system (including removable jackets or boxes) shall be tested and documented in accordance with the specified fire type and duration for the equipment location area, e.g.:

Delete first list item of first paragraph

In second list item of first paragraph, add after EN 1363-2

, ISO 834-3 or UL1709

Delete last sentence of second list item of first paragraph

Delete second and third sentence of third item of first paragraph

jet-fire testing- insulation used for passive fire protection against a jet-fire shall be tested in accordance with the method described in ISO 22899-1.

Remove fourth list item of first paragraph

Replace section 5.2.2 title with

### 5.2.2 Class 6, 7, 8 and D: Acoustic insulation

In first paragraph, replace "All systems" with

For class 6,7, 8 and D the insulation system

Add to section

Acceptance criteria for class D shall be as given in table F1.

### 5.2.3 Sealing of penetrations

Delete section 5.2.3

## 5.3 Insulation procedure

### 5.3.1 Insulation procedure specification (IPS)

In first paragraph, replace first sentence with

A detailed IPS shall be established.

Replace second list item of second paragraph with

— technical data sheet and material safety data sheet for all type of materials;

### 5.3.2 Drawings for penetration seals

Delete section 5.3.2

### 5.3.3 Inspection and test plan (ITP)



PETROBRAS

**TECHNICAL SPECIFICATION**

No. I-ET-3010.00-1200-431-P4X-001

REV: H

AREA

-

SHEET:

14 of 57

TITLE:

**THERMAL INSULATION FOR MARITIME INSTALLATIONS**

ESUP

INTERNAL

In first sentence of first paragraph, delete "both" and "and inspection log"

Add new section

#### **5.3.4. Isometrics and drawings**

The pipings isometric and equipment general arrangement drawing shall state the designated insulation material and respective thickness.

The isometrics shall state the location for the insulation windows for inspection in accordance with requirements of I-ET-3010.00-1200-970-P4X-013 - COMPLIANCE WITH NR-13 AND SPIE REQUIREMENTS.

## **6 MATERIALS**

### **6.1 Environmentally requirements**

Delete section 6.1

### **6.2 Selection of insulation materials**

Delete second sentence of first paragraph

Delete third sentence of second paragraph

Delete third paragraph

Replace first sentence of fourth paragraph with

The insulation materials shall be as per MDSs in Annex D::

Add to list

- Calcium Silicate (CS);
- Expanded Perlite (EP);
- Polyisocyanurate (PIR).



PETROBRAS

TECHNICAL SPECIFICATION

No. I-ET-3010.00-1200-431-P4X-001

REV: H

AREA

-

SHEET:

15 of 57

TITLE:

THERMAL INSULATION FOR MARITIME INSTALLATIONS

ESUP

INTERNAL

Replace Table 1 with

Table 1 – Selection of insulation material

Insulation class	Offshore + Onshore with corrosivity category C5 or higher according to ISO 9223, Annex C	Onshore with corrosivity category C4 or lower according to ISO 9223, Annex C
1 Heat conservation	Aerogel, AES fibre <sup>1)</sup> , Cellular glass <sup>1)</sup> or Mineral wool <sup>1), 2)</sup>	Aerogel, AES fibre <sup>1)</sup> , Calcium silicate <sup>1)</sup> , Cellular glass, Expanded perlite, FEF or Mineral wool
2 Cold medium conservation	Aerogel, Cellular glass or PIR <sup>3</sup>	Aerogel, Cellular glass, FEF or PIR
3 Personnel protection	Tn ≤ 250 °C: Insulating coating or personnel guards	Tn ≤ 250 °C: Insulating coating or personnel guards
	Tn ≥ 250 °C: as class 1	Tn ≥ 250 °C: as class 1
	Tn < -10 °C: Personnel guards	Tn < -10 °C: Personnel guards
4 Frost protection	Aerogel, Cellular glass <sup>1)</sup> or Mineral wool <sup>1), 2)</sup>	Aerogel, Cellular glass or Mineral wool
5 Fire protection	As per qualified system (5.2.1)	As per qualified system (5.2.1)
6, 7, 8 and D Acoustic insulation	As per qualified system (5.2.2)	As per qualified system (5.2.2)
9 External condensation and icing protection	Aerogel or Cellular glass <sup>1)</sup>	Aerogel, Cellular glass, FEF or PIR

Notes

1) At Tn < 180 °C AES, Calcium silicate, Cellular glass and mineral wool shall only be used as part of a non-contact insulation system or used as a secondary (outer layer) insulation material applied over e.g. aerogel. Minimum 20 mm air gap between insulation material and metallic surface of flange/valve in insulation boxes is a type of non-contact insulation.

2) In mechanically ventilated room with no sprinkler/deluge system, mineral wool may be used directly on pipes/vessels with Tn > 40 °C. Indoor areas with regular cleaning or testing of seawater deluge system are not considered dry.

3) Only for cryogenic temperature.

NOTE For insulation of equipment and piping in service with self-igniting fluid (i.e. ethylene oxide) an insulation materials with closed cell structure (i.e. cellular glass) that is non-reactive to the fluid shall be used.

Add to section

The default insulation material for Class 1, 2, 4, and 9 is Aerogel for operational temperature bellow 250°C, and for cyclic service temperature.

For steam services, including condensate and polished water is mandatory the use of aerogel as insulation material.

Mineral wool insulation materials shall not be applied directly over uncoated stainless steel materials, austenitic stainless steel (such as AISI 316 or AISI 316L), duplex and superduplex



PETROBRAS

**TECHNICAL SPECIFICATION**

No. I-ET-3010.00-1200-431-P4X-001

REV: H

AREA

-

SHEET:

16 of 57

TITLE:

**THERMAL INSULATION FOR MARITIME INSTALLATIONS**

ESUP

INTERNAL

stainless steels or super-austenitic stainless steels. An aluminum foil (wrapped around the equipment or pipe) is required to protect the base metal.

Chilled water piping insulation material shall be Flexible Elastomeric Foam (FEF) with metallic cladding. The adhesive shall be applied as FEF manufacturer instructions.

**6.3 Selection of cladding**

**Table 3 – Selection of cladding material**

Replace Table 3 with

Insulation class	Cladding material
All, except class 5 or F	Stainless steel: SS316 <sup>1)</sup> GRP FEM with reinforcement FEM without reinforcement For onshore only: Aluminium alloy: 3003 H14 or 3105 H14
5 or F	Cladding to be tested and documented as part of the system

**Note**

<sup>1)</sup> SS304 may be used onshore with corrosivity category C4 or lower according to ISO 9223, Annex C, if specified by the purchaser.

**6.3.1 Metallic cladding**

**6.3.1.1**

Replace IOGP and NORSOK first paragraph with

Type of stainless steel cladding shall be one of the following:

- ASTM 240M type SS316;
- EN10088-2 number 1.4401;

The stainless steel cladding shall have 2D finish.

The thickness of the stainless steel cladding shall be according to table 4.


**Table 4 – Cladding thickness, SS304 and SS316**

Replace Table 4 with

Thickness, minimum	OD < 250 mm	250 mm ≤ OD ≤ 900 mm	OD > 900 mm
SS304 and SS316 2D sheet	0,5 mm	0,7 mm	0,9 mm

**6.3.1.2 Aluminium alloy**

Replace first paragraph with

	<b>TECHNICAL SPECIFICATION</b>	No. I-ET-3010.00-1200-431-P4X-001	REV: H
	AREA: -	SHEET: 17 of 57	
	TITLE:	<b>THERMAL INSULATION FOR MARITIME INSTALLATIONS</b>	
ESUP			
INTERNAL			
<p>Aluminium cladding shall be of type 3003 H14 or 3105 H14 according to ISO 6361, ASTM B209 or EN 485.</p> <p>Thickness of aluminium cladding shall be according to table 5 or ASTM C1729.</p> <p><b>6.3.1.3 Aluzinc</b></p> <p><u>Delete section 6.3.1.3</u></p> <p><b>6.3.2 Non-metallic cladding</b></p> <p><u>Replace first paragraph with</u></p> <p>Non-metallic cladding shall be according the MDS GRP, MDS FEM with reinforcement or MDS FEM without reinforcement in Annex D.</p> <p><u>Delete second paragraph</u></p> <p><u>Delete third paragraph</u></p> <p><u>Delete fourth paragraph</u></p> <p><u>Delete Table 7</u></p> <p><u>Delete fifth paragraph</u></p> <p><u>Delete sixth paragraph</u></p> <p><b>6.4 Aluminium foils</b></p> <p><u>Delete second paragraph</u></p> <p><u>Add to section</u></p> <p>If materials others than aluminium foil are used for vapour barrier, the MDSs shall be included in the IPS and be approved by Company.</p> <p><b>6.5 Sealers and sealing tape and gasket</b></p> <p><u>Add to section</u></p> <p>Flexibility shall be documented by test reports or track record field experience.</p> <p><u>Add to section</u></p> <p>The test shall be according to ISO 12944-9, Annex B Cyclic aging test.</p> <p><u>Add to section</u></p> <p>The joint sealer after the test shall remain flexible and be well bounded to the substrate without surface cracks when visually examined under X7 magnification.</p> <p><b>6.6 Perforated guards</b></p> <p><u>Delete fourth paragraph</u></p>			



PETROBRAS

**TECHNICAL SPECIFICATION**

No. I-ET-3010.00-1200-431-P4X-001

REV: H

AREA

-

SHEET:

18 of 57

TITLE:

**THERMAL INSULATION FOR MARITIME INSTALLATIONS**

ESUP

INTERNAL

**6.7 Accessories**

Replace second sentence of first paragraph with

For aluminium cladding direct contact between the aluminium cladding and SS316 accessories shall be avoided by using a polymer gasket, washer etc.

**Table 8 - Steel banding and locking clips**

Add NOTE to Table 8

NOTE The values are minimum values.

Add new sections

**6.7.1. SEAL**

Stainless steel seal type 316, according to ASTM A167 and A480, 12.7 mm or 19 mm width and with a thickness of 1.0 mm (Figure A.1).

**6.7.2. SCREW**

Self-tapping Type A stainless steel screw type 316, 1/8 "diameter, 1/2" length, slotted pan head.

Self-tapping Type A stainless steel screw type 316, 3/16 "diameter, 3/4" length, hexagonal head with slotted, crimped.

**6.7.3. WASHER**

Stainless steel flat washer type 316, for 3/16 "bolt, 7/8" outside diameter, internal diameter of 7/32 inch and thickness of 1/16 inch.

Stainless steel flat washer type 316, for 1/8 inch bolt, 5/8 inch outer diameter, 5/32 inch inner diameter and 3/64 inch thickness.

**6.7.4. QUICK COUPLING AND CLASP**

Fastening and quick coupling of type 316 stainless steel, according to ASTM A167 and A480 / A480M. The requirements of dimensions at Figure A.2 shall be followed.

SELLER may present an alternative configuration for BUYER previous approval.

**6.7.5. INSPECTION WINDOWS**

The inspection windows for periodic measurements of thickness in pipes and pressure vessels shall be in accordance with Figure A.3 and Figure A.4 for OD>200mm. Whenever possible the solution presented at Figure A.4 shall be used. SELLER may present an alternative configuration for BUYER previous approval.

For pipes and pressure vessels with OD<200mm, SELLER shall present alternative configuration for the inspection window.

**6.7.6. HEXAGONAL WIRE REINFORCEMENT MESH**

Consisting of wire of diameter 0.56 mm to 0.86 mm (BWG 24 to 20), 12 mm or 25 mm mesh of stainless steel according to ASTM A492, type 316.

Add new section



PETROBRAS

**TECHNICAL SPECIFICATION**

No. I-ET-3010.00-1200-431-P4X-001

REV: H

AREA

-

SHEET:

19 of 57

TITLE:

**THERMAL INSULATION FOR MARITIME INSTALLATIONS**

ESUP

INTERNAL

## 6.8 Insulating coating

Company approved insulating coating for class 3 shall be applied in accordance with the supplier's recommendations.

Add to Section

The PAINT MANUFACTURER shall present documented testing or field experience relevant to the specific intended use for the insulation coating for BUYER evaluation.

Add new section

### 6.9. Coating under insulation

The requirements for coating under insulation shall be in accordance with I-ET-3010.00-1200-956-P4X-002 – GENERAL PAINTING.

## 7 DESIGN ENGINEERING

In first paragraph, replace "P&IDs', and piping isometrics" with

P&IDs', Gas and piping isometrics

Delete second paragraph

Delete ninth paragraph

Delete tenth paragraph

### 7.1 Designing for insulation

Replace third paragraph with

Insulation adjacent to flanges in piping and equipment shall be terminated to allow removal of bolts without damage to insulation. Minimum free space from the flange to the nearest part of the insulation shall be equal to 1.2 times the bolt length, and not to be less than 130 mm. If the exposed section between the flange and the insulation is greater than 300 mm, removable insulation shall be installed. The termination of the weather protection shall not allow ingress of water.

#### 7.1.1 Class 1: Heat conservation

Add to list

- Piping and equipment sporadically cooled or heated as: Relief valves and relief systems (except for products with pour point above room temperature); Vents and drains (except for products with pour point above room temperature); Flare system; Drainage system;
- Fans, blowers and reciprocating compressors, centrifugal and rotary;
- Chillers and condensers, with their associated pipes;



PETROBRAS

**TECHNICAL SPECIFICATION**

No. I-ET-3010.00-1200-431-P4X-001

REV: H

AREA

-

SHEET:

20 of 57

TITLE:

**THERMAL INSULATION FOR MARITIME INSTALLATIONS**

ESUP

INTERNAL

- Mixers;
- Nameplate;
- Supports of pipes and equipment.
- Vapour traps;
- Expansion joint bellows;
- Flanged neck with a length equal to or less than 300 mm;
- Hoses;

Add to end of section

Instruments shall be insulated in order to assure, on the outer surface, a temperature not above 60°C. The reading of the instruments shall be kept possible after insulation.

### 7.1.3 Insulation of valves and flanges

Delete first paragraph

Delete third sentence of second paragraph

Delete fourth sentence of second paragraph

In third paragraph, replace "suitable for quick removal and reinstallation." with

used.

Delete fourth paragraph

In first sentence of fifth paragraph, replace "which shall be frequently subject for inspection and maintenance" with

when specified

Delete third sentence of fifth paragraph

In first sentence of sixth paragraph, replace "with the "roof tile" principles" with

for water shedding

Add to end of sixth paragraph

the top of the box shall have 10° incline from the horizontal plane on top of the box.

Add to section

An extended valve stem or extended bonnet shall be used to accommodate the specified box insulation thickness.



PETROBRAS

**TECHNICAL SPECIFICATION**

No. I-ET-3010.00-1200-431-P4X-001

REV: H

AREA

-

SHEET:

21 of 57

TITLE:

**THERMAL INSULATION FOR MARITIME INSTALLATIONS**

ESUP

INTERNAL

## 7.2 Calculation of insulation thickness

### 7.2.1 Class 1, 2, 4 and 9

In first paragraph, add after "EN ISO 12241"

or ASTM C680

Replace second paragraph with

For thermal calculations on non-contact insulation systems, the thermal conductivity of annular gap/void provided by the spacer system shall be accounted for in thickness calculations.

#### Add to section

For hot insulation the greater thickness resulting from the following approaches shall be used:

- a) Personnel Protection: The calculation of the insulation thickness required for personnel protection is based on limiting the surface temperature to the maximum allowable value. This is a safety requirement;
- b) Special purpose requirements: The minimum required insulation thickness for purpose of Process Control or any other requirements established by the project.

For cold insulation the greater thickness resulting from the following approaches shall be used:

- a) Condensation control: When the process temperature is below the maximum ambient temperature, the minimum required insulation thickness which prevents surface condensation is calculated;
- b) Maximum Heat Gain: When the process temperature is below the maximum ambient temperature, the minimum insulation thickness is calculated required to achieve the maximum allowable heat gain;
- c) Special purpose requirements: The minimum required insulation thickness for the purpose of Freeze Protection, Process Control, boil-off control or any other requirements established by the project;

For cold conservation, the thermal insulation shall assure, on the outer surface, a temperature above the dew point.

For product fluid maintenance in pipes, the insulation shall be dimensioned in such a way that the temperature of the product at the end of the line is at least 10°C above its pour point.

A reference table for insulation thickness class 1 and 3 are presented Appendix B.



PETROBRAS

**TECHNICAL SPECIFICATION**

No. I-ET-3010.00-1200-431-P4X-001

REV: H

AREA

-

SHEET:

22 of 57

TITLE:

**THERMAL INSULATION FOR MARITIME INSTALLATIONS**

ESUP

INTERNAL

**7.2.2 Class 3**

Replace first paragraph of IOGP and NORSOK with

For processes with operating temperature below 0 °C or above 60°C, personnel protection, class 3, shall be used. Class 3 shall only be installed if the pipe or equipment are closer than 2 m vertically and 1 m horizontally to walkways and normal working areas. Guards installed for normal operating temperatures under and included 250 °C shall be made of perforated SS316 plate or insulating coating. For normal operating temperatures above 250 °C, the insulation thickness shall be calculated in accordance with EN ISO 12241 or ASTM C680.

**Table 9 – Length of distance holders**

Replace table 9 with

Nominal pipe size (DN)	Normal operation temperature (°C)	
	60 °C ≤ Tn ≤ 250 °C	Tn < -10 °C
DN < 250 mm	50 mm	50 mm
DN ≥ 250 mm	100 mm	50 mm

Delete fourth paragraph

**7.2.3 Class 5 and F**

Delete third paragraph

**7.3 Combination of insulation classes**

**7.3.1 General**

Replace first paragraph with

For insulation systems with combinations of insulation class, the insulation system shall fulfill the insulation requirement for each insulation class.

Delete second paragraph

**7.3.2 Thermal insulation and/or personnel protection combined with fire protection**

Delete section 7.3.2

**7.3.3 Thermal insulation and/or personnel protection combined with acoustic insulation**

Delete section 7.3.3

**7.3.4 Fire protection combined with acoustic insulation**

Delete section 7.3.4



PETROBRAS

**TECHNICAL SPECIFICATION**

No. I-ET-3010.00-1200-431-P4X-001

REV: H

AREA

-

SHEET:

23 of 57

TITLE:

**THERMAL INSULATION FOR MARITIME INSTALLATIONS**

ESUP

INTERNAL

**7.3.5 Thermal insulation and/or personnel protection combined with fire protection and acoustic insulation**

Delete section 7.3.5

**8 INSTALLATION AND INSPECTION**

**8.1 General**

In first sentence, replace "P&ID, piping isometric, data sheets and IPS" with

P&ID, GA, piping isometric, data sheets and IPS

Add to section

The recommendations regarding design stated at API RP 583 to mitigate corrosion under insulation shall be followed.

Construction and Finishing details of CINI Manual not conflicting with this technical specification are considered approved design.

Inspections windows shall be provided in carbon steel piping systems, pressure vessels and tanks, in order to allow inspection for ultrasonic measurement and control of wall thickness loss as established at I-ET-3010.00-1200-970-P4X-013 - COMPLIANCE WITH NR-13 AND SPIE REQUIREMENTS.

Expansion joints for the insulation shall be added whenever a rigid thermal insulator is installed, according to the maximum spacing oriented in Table 1. The expansion joints shall be wide between 20 mm and 25 mm. The joint filling shall be made with flexible insulating material.

**Table 1 - Maximum Spacing for Expansion Joints**

Temperature (°C)	Maximum joint spacing expansion (m)	
	Ferritic Steels	Austenitic steels
100	23	14
150	12	8.5
200	8	6
250	6	4.5
300	5	3.5

Based on Table 4 of ASTM C1696.

**8.1.1 Workmanship**

Delete fifth paragraph

**8.1.3 Insulation with vapour barrier**

Add to end of first list item of third paragraph

for cryogenic temperatures

Add to section

In order to avoid condensation on pipe supports or penetration of water, shall be used of insulated prefabricated pipe supports or the vapour barrier shall extend with a minimum length of 3 times the insulation thickness on the support area.

**8.2 Piping insulation**Add to section

The interference pieces shall be assembled to the same thickness as the insulation of the pipe or equipment to which they belong, extending in a length equal to four times the thickness of the insulation or at least 300 mm (Figure A.8).

Pipes supported directly on supports with rebar or similar shall have the insulation interrupted in the region of the support. Piping with skids shall be insulated in the support region (Figure A.6 and Figure A.7).

Contraction joints shall be provided for every 25 m of pipe length.

NOTE The existence of a flange or valve along the stretch replaces the shrink joint.

For pre molded insulation installation, the Figure A-9 shall be observed.

**8.3 Vessel insulation****8.3.1 Vessel insulation**Add to section

Removable insulation covers shall be provided for removable vessels heads. For heat exchangers the Figure A-10 shall be observed.

Pressure vessel with a perimeter greater than 6 000 mm and a temperature of operation above 150°C shall have, in the support straps of the last layer of the insulating material and protection plate, a sine or helical spring for each 6,000 mm or fraction, on the perimeter, to compensate for thermal expansion

**8.3.2 Segment insulation of vessel****8.3.2.1 Insulation with vapour barrier**Delete first paragraph**8.4 Cladding****8.4.1 Metallic cladding**



PETROBRAS

**TECHNICAL SPECIFICATION**

No. I-ET-3010.00-1200-431-P4X-001

REV: H

AREA

-

SHEET:

25 of 57

TITLE:

**THERMAL INSULATION FOR MARITIME INSTALLATIONS**

ESUP

INTERNAL

Replace first sentence of first paragraph with

All cladding seams shall be installed to shed water.

In first sentence of second paragraph, replace "pipelines" with

pipes

Add to second paragraph

Longitudinal seams shall be crimped 30 mm from the edge on one side for OD < 150 mm and 50 mm from the edge on one side for OD ≥ 150 mm.

Add to second paragraph

Longitudinal seams shall be staggered.

In first sentence of third paragraph, replace "pipelines" with

pipes

In first sentence of seventh paragraph, add before "sealant"

flexible, non-hardening elastomeric

Add to seventh paragraph

The sealant shall be applied prior to the closure of the seam.

Add to seventh paragraph

The sealant shall be (25 +/- 5) mm wide and (3 +/- 1) mm thick.

Add to seventh paragraph

The sealant shall be applied to display continuously external 2 to 3 mm of sealant at completed seam.

Delete twelfth paragraph

Add to fourteenth paragraph


Metal bands shall be installed on circumferential overlaps and in the middle of circumferential overlaps with a minimum c/c of 250 mm.

Add to section

All screws and rivets shall be sealed to prevent infiltration of water through the hole in the protective cladding

**8.4.2 Non-metallic cladding**

Delete first paragraph

	<b>TECHNICAL SPECIFICATION</b>	No. I-ET-3010.00-1200-431-P4X-001	REV: H
	AREA	-	
	TITLE:	<b>THERMAL INSULATION FOR MARITIME INSTALLATIONS</b>	
		SHEET:	26 of 57
		ESUP	
		INTERNAL	

Replace second sentence of second paragraph with

If the maximum temperature of piping exceeds the maximum service temperature of the non-metallic cladding, a special termination solution against piping shall be made.

### **8.4.3 GRP**

Replace section with

The installation of GRP cladding shall be according to MDS GRP.

## **8.5 Flanges and valves**

### **8.5.1 General**

Add to second paragraph

Insulation boxes shall overlap with minimum insulation thickness on connection pipes.

Add to section

All cut-outs in the insulation boxes shall be sealed to avoid water ingress.

### **8.5.2 Surface material for jackets**

Replace first sentence of first paragraph with

The jacket shall prevent water ingress.

Replace second sentence of first paragraph with

The material shall have an adequate wear resistance to withstand frequent handling and normal wear and tear.

Replace third sentence of first paragraph with

The surface material shall be tested for reaction to fire according to ASTM E84 or EN 13501-1.

Delete second paragraph

Delete guidance note

Add to section


Material properties for surface material and sewing thread shall be documented and included in the IPS.

### **8.5.3 Insulation materials for prefabricated boxes**

Add to section

For insulation classes without a vapour barrier, there shall be a minimum 20 mm air gap between flange/valve and the insulation material except for penetrations in the box (pipe, stem, etc).

### **8.5.4 Insulation boxes with vapour barrier**

	<b>TECHNICAL SPECIFICATION</b>	No. I-ET-3010.00-1200-431-P4X-001	REV: H
	AREA	-	
	TITLE:	<b>THERMAL INSULATION FOR MARITIME INSTALLATIONS</b>	
		SHEET:	27 of 57
		ESUP	
		INTERNAL	

Delete first sentence of first paragraph

Delete second sentence of first paragraph

Delete second paragraph

### **8.5.6 Identification**

Delete third paragraph

### **8.7 Drainage**

In first paragraph, replace "10" with

15

### **8.8 Instrument insulation**

Delete section

### **8.9 Sealing of penetrations**

Delete section

### **8.10 Inspection**

Add Note

NOTE Annex E provides a checklist of typical inspection activities related to installation of insulation.



**PETROBRAS**

**TECHNICAL SPECIFICATION**

No. I-ET-3010.00-1200-431-P4X-001

REV: H

AREA

-

SHEET:

28 of 57

TITLE:

**THERMAL INSULATION FOR MARITIME INSTALLATIONS**

**ESUP**

**INTERNAL**

**Annex A**  
(informative)  
**Key data for insulation**

Delete Annex A



**PETROBRAS**

**TECHNICAL SPECIFICATION**

No. I-ET-3010.00-1200-431-P4X-001

REV: H

AREA

-

SHEET:

29 of 57

TITLE:

**THERMAL INSULATION FOR MARITIME INSTALLATIONS**

ESUP

INTERNAL

**Annex B**  
(normative)  
**General**

Delete Annex B



**PETROBRAS**

**TECHNICAL SPECIFICATION**

No. I-ET-3010.00-1200-431-P4X-001

REV: H

AREA

-

SHEET:

30 of 57

TITLE:


**THERMAL INSULATION FOR MARITIME INSTALLATIONS**

ESUP

INTERNAL

**Annex C**  
(informative)  
**Test piece for site test**

Delete Annex C

 <b>PETROBRAS</b>	<b>TECHNICAL SPECIFICATION</b>	No. I-ET-3010.00-1200-431-P4X-001	REV: H
	AREA: -	SHEET: 31 of 57	
	TITLE:	<b>THERMAL INSULATION FOR MARITIME INSTALLATIONS</b>	

ESUP  
INTERNAL

**Annex D**  
 (normative)  
**Material Data Sheets (MDSs)**

Replace section with

The materials shall be delivered in accordance with the standard referred to in the MDS. In addition, the MDS specifies the selected options in the referred standard and additional requirements which shall be added or shall supersede the corresponding requirements in the referred standard. For tests, specified in the MDS for insulation materials, that are not included in the insulation material standard given in the MDS, the tests shall be material or product qualification tests and shall not be regular production tests. The tests specified in the MDS for non-metallic cladding shall be material or product qualification tests and shall not be regular production tests. Where the MDS does not specify any additional requirements all the requirements of the referred standard apply. The latest edition of the referred standard shall apply unless a specific year of issue is specified by the purchaser.



PETROBRAS

**TECHNICAL SPECIFICATION**

No. I-ET-3010.00-1200-431-P4X-001

REV: H

AREA

-

SHEET:

32 of 57

TITLE:

**THERMAL INSULATION FOR MARITIME INSTALLATIONS**

ESUP

INTERNAL

Replace MDS AES with

MATERIAL DATA SHEET		MDS AES	Rev. 01
<b>TYPE OF MATERIAL: Alkali Earth Silicate (AES)</b>			
Standard	Grade / Type	Additional requirements	
<b>ASTM C892</b> <i>(EN standard not available. ASTM standard to be used in Europe)</i>	Type II, grade 6 and 8	Section 11.1.9 ASTM E84 and ASTM E136	
<b>General</b>	This MDS specifies the selected options in the referred standard and additional requirements which shall be added or shall supersede the corresponding requirements in the referred standard. Products shall meet the requirements for bio-soluble fibres in Note Q of Regulation (EC) No. 1272/2008.		
<b>Products</b>	AES insulation products are supplied in slabs and blankets.		
<b>Application</b>	AES can be used for class 1 and 3. At normal operation temperatures < 180 °C, AES can only be used as part of a non-contact insulation system or as a secondary (outer layer) insulation material applied over e.g. aerogel.		
<b>MATERIAL DATA AND PROPERTIES (additional testing and acceptance criteria)</b>			
Standard	ASTM C892		
Traces of water soluble ions and pH	Section 11.1.9		
Reaction to fire	ASTM E136 and ASTM E84		
<b>INSTALLATION REQUIREMENTS</b>			
General	Installation according to installation manual from Manufacturer. For classes 5, 6, 7 and 8, installation shall be done as described in the relevant test reports / installation instructions for the qualified systems.		



PETROBRAS

**TECHNICAL SPECIFICATION**

No. I-ET-3010.00-1200-431-P4X-001

REV: H

AREA

-

SHEET:

33 of 57

TITLE:

**THERMAL INSULATION FOR MARITIME INSTALLATIONS**

ESUP

INTERNAL

Replace MDS AG with

MATERIAL DATA SHEET		MDS AG	Rev. 01
<b>TYPE OF MATERIAL: Aerogel (AG)</b>			
Standard	Grade / Type	Additional requirements	
<b>ASTM C1728</b>	Type I: Grade 1B Type III: Grade 1A and 2A	Section 7.11	
<b>EAD 040643-00-1201</b>		Section 2.2.1 (Acceptance criteria) Section 2.2.2 EN 14607 / EN 14707 EN 13468	
<b>General</b>	This MDS specifies the selected options in the referred standard and additional requirements which shall be added or shall supersede the corresponding requirements in the referred standard.		
<b>Products</b>	Blankets		
<b>Application</b>	Aerogel can be used for all insulation classes.		
<b>MATERIAL DATA AND PROPERTIES (additional testing and acceptance criteria)</b>			
Standard	ASTM C1728	EAD 040643-00-1201	
Maximum service temperature		EN 14706 / EN 14707	
Water absorption		Section 2.2.2	
Traces of water soluble ions and pH	Section 7.11	EN 13468, Acceptance criteria: Figure 1 in ASTM C795 pH-value = 7-12,5	
Reaction to fire		Section 2.2.1, Acceptance criteria: minimum B-s1, d0	
<b>INSTALLATION REQUIREMENTS</b>			
<b>General</b>	Installation according to installation manual from Manufacturer. For classes 5, 6, 7 and 8, installation shall be done as described in the relevant test reports / installation instructions for the qualified systems.		



PETROBRAS

TECHNICAL SPECIFICATION

No. I-ET-3010.00-1200-431-P4X-001

REV: H

AREA

-

SHEET:

34 of 57

TITLE:

THERMAL INSULATION FOR MARITIME INSTALLATIONS

ESUP

INTERNAL

Replace MDS CG with

MATERIAL DATA SHEET		MDS CG	Rev. 01
<b>TYPE OF MATERIAL: Cellular glass (CG)</b>			
<b>Standard</b> <i>Either ASTM or EN standard shall be used.</i>	<b>Grade / Type</b>	<b>Additional requirements</b>	
<b>ASTM C552</b>	Grade 6	Section 12.10 ASTM E136 and ASTM E228	
<b>EN 14305</b>		Section 4.2.4 (Acceptance criteria) Sections 4.3.2, 4.3.3, 4.3.4, 4.3.10, 4.3.11, 4.3.12, C.6 and C.7	
<b>General</b>	This MDS specifies the selected options in the referred standard and additional requirements which shall be added or shall supersede the corresponding requirements in the referred standard.		
<b>Products</b>	Cellular glass insulation products are supplied as prefabricated piping and equipment elements / sections. The product shall be delivered with anti-abrasive coating if used directly on piping / equipment.		
<b>Application</b>	CG can be used for thermal insulation for all insulation classes. At normal operation temperatures < 180 °C, cellular glass can only be used as part of a non-contact insulation system or as a secondary (outer layer) insulation material applied over e.g. aerogel for offshore and onshore with corrosivity category C5 or higher according to ISO 9223 Annex C. CG can be use alone or in combination with other materials for class 5, 6,7 and 8 as per qualified system. For temperature above +180 °C, an outside reinforcement mesh/coating should be used.		
<b>MATERIAL DATA AND PROPERTIES (additional testing and acceptance criteria)</b>			
<b>Standard</b>	<b>ASTM C552</b>	<b>EN 14305</b>	
Maximum service temperature		Section 4.3.2	
Minimum service temperature		Section 4.3.3	
Density		Section C.7	
Water absorption		Section 4.3.10	
Traces of water soluble ions and pH	Section 12.10	Section 4.3.12, Acceptance criteria: Figure 1 in ASTM C795 pH-value = 7-12,5	
Reaction to fire	ASTM E136	Section 4.2.4, Acceptance criteria: A1	
Compressive strength		Section 4.3.4, Acceptance criteria: Level CS(Y) 500	
Water vapour diffusion resistance		Section 4.3.11, Acceptance criteria: $\mu \approx \infty$	
Coefficient of thermal expansion/ contraction	ASTM E228	Section C.6	



PETROBRAS

TECHNICAL SPECIFICATION

No. I-ET-3010.00-1200-431-P4X-001

REV: H

AREA

-

SHEET:

35 of 57

TITLE:

THERMAL INSULATION FOR MARITIME INSTALLATIONS

ESUP

INTERNAL

MATERIAL DATA SHEET

MDS CG (continued)

Rev. 01

INSTALLATION REQUIREMENTS

General	<p>Installation according to installation specification from Manufacturer.</p> <p>For classes 5, 6, 7 and 8 installation shall be done as described in the relevant test reports / installation instructions for the qualified systems.</p> <p>Anti-abrasive coating shall be used to prevent damage to cellular glass and coating systems. The anti-abrasive coating shall be completely dry before the insulation material is mounted. The anti-abrasive coating shall be suitable at maximum operation temperatures.</p> <p>After wet applied anti-abrasive coating is applied, the surface shall have a smooth finish.</p> <p>For systems without vapour barrier, no sealant shall be used in the longitudinal and circumferential CG joints.</p> <p>For system with vapour barrier and a single layer application, all longitudinal and circumferential CG joint shall be sealed with a joint sealant. For a multi-layer application, only the longitudinal and circumferential CG joint of the uppermost layer shall be sealed with joint sealant.</p>
Piping	<p>CG shall be prefabricated as pipe insulation elements according to dimensions and shape. To cover fittings and other irregular surfaces, sections may be cut and fitted on site.</p> <p>Minimum thickness up to DN150 shall be 30 mm. Above DN150, minimum thickness shall be 40 mm.</p>
Vessel	<p>CG vessel (DN200) segments shall be mechanically fastened and tightened with metal bands. For ≤DN150 segments, glass fibre reinforced tape shall be used.</p>
CG with non-metallic cladding	<p>Prefabricated CG with factory applied non-metallic cladding shall be joint sealed with suppliers recommended sealant.</p>



PETROBRAS

TECHNICAL SPECIFICATION

No. I-ET-3010.00-1200-431-P4X-001

REV: H

AREA

-

SHEET:

36 of 57

TITLE:

THERMAL INSULATION FOR MARITIME INSTALLATIONS

ESUP

INTERNAL

Add new MDS CS

MATERIAL DATA SHEET		MDS CS	Rev. 01
<b>TYPE OF MATERIAL: Calcium silicate (CS)</b>			
<b>Standard</b> <i>Either ASTM or EN standard shall be used.</i>	<b>Grade / Type</b>	<b>Additional requirements</b>	
<b>ASTM C533</b>	Type 1		
<b>EN 14306</b>		Section 4.2.4 (Acceptance criteria) Sections 4.3.2, 4.3.5 and D.9	
<b>General</b>	This MDS specifies the selected options in the referred standard and additional requirements which shall be added or supersede the corresponding requirements in the referred standard.		
<b>Products</b>	The products are manufactured in the form of boards, pipe section, segments and prefabricated ware.		
<b>Application</b>	CS can be used onshore with corrosivity category C4 or lower according to ISO 9223 Annex C for systems with continuously temperature higher than 180°C.		
<b>MATERIAL DATA AND PROPERTIES (additional testing and acceptance criteria)</b>			
<b>Standard</b>	<b>ASTM C533</b>	<b>EN14306</b>	
Maximum service temperature		Section 4.3.2	
Density		Section D.9	
Traces of water soluble ions		Section 4.3.5, Acceptance criteria: Figure 1 in ASTM C795 pH=7-12,5	
Reaction to fire		Section 4.2.4, Acceptance criteria: Class A	
<b>INSTALLATION REQUIREMENTS</b>			
<b>General</b>	Installation according to installation manual from Manufacturer. For classes 5, 6, 7 and 8, installation shall be done as described in the relevant test reports / installation instructions for the qualified systems.		



PETROBRAS

**TECHNICAL SPECIFICATION**

No. I-ET-3010.00-1200-431-P4X-001

REV: H

AREA

-

SHEET:

37 of 57

TITLE:

**THERMAL INSULATION FOR MARITIME INSTALLATIONS**

ESUP

INTERNAL

Add new MPS EP

MATERIAL DATA SHEET		MDS EP	Rev. 01
<b>TYPE OF MATERIAL: Expanded Perlite (EP)</b>			
<b>Standard</b> <i>Either ASTM or EN standard shall be used.</i>	<b>Grade / Type</b>	<b>Additional requirements</b>	
<b>ASTM C610</b>		ASTM C302 / ASTM C303	
<b>EN 15501</b>		Section 4.2.4 (Acceptance criteria) Sections 4.3.2, 4.3.5, 4.3.7 + E.8	
<b>General</b>	This MDS specifies the selected options in the referred standard and additional requirements which shall be added or supersede the corresponding requirements in the referred standard.		
<b>Products</b>	The products are manufactured in the form of boards, pipe sections, segments and prefabricated ware.		
<b>Application</b>	EP can be used onshore with corrosivity category C4 or lower according to ISO 9223 Annex C for systems with temperature higher than ambient.		
<b>MATERIAL DATA AND PROPERTIES (additional testing and acceptance criteria)</b>			
<b>Standard</b>	<b>ASTM C610</b>	<b>EN 15501</b>	
Maximum service temperature		Section 4.3.2	
Density	ASTM C302 / ASTM C303	E.8	
Water absorption		Section 4.3.7	
Traces of water soluble ions and the pH value		Section 4.3.5, Acceptance criteria: Figure 1 in ASTM C795 pH=7-12,5	
Reaction to fire		Section 4.2.4, Acceptance criteria: Class A	
<b>INSTALLATION REQUIREMENTS</b>			
<b>General</b>	Installation according to installation manual from Manufacturer. For classes 5, 6, 7 and 8, installation shall be done as described in the relevant test reports / installation instructions for the qualified systems.		



PETROBRAS

TECHNICAL SPECIFICATION

No. I-ET-3010.00-1200-431-P4X-001

REV: H

AREA

-

SHEET:

38 of 57

TITLE:

THERMAL INSULATION FOR MARITIME INSTALLATIONS

ESUP

INTERNAL

Replace MDS FEF with

MATERIAL DATA SHEET	MDS FEF	Rev. 01
---------------------	---------	---------

**TYPE OF MATERIAL: Flexible Elastomeric Foam (FEF)**

<b>Standard</b> <i>Either ASTM or EN standard shall be used.</i>	<b>Grade / Type</b>	<b>Additional requirements</b>
<b>ASTM C534/C534M</b>	Grade 3	ASTM D1622
<b>EN 14304</b>		Section 4.2.4 (Acceptance criteria) Sections 4.3.2, 4.3.3, 4.3.5 and 4.3.6 and D4
<b>General</b>	This MDS specifies the selected options in the referred standard and additional requirements which shall be added or supersede the corresponding requirements in the referred standard. Either ASTM or EN standard shall be used.	
<b>Products</b>	Flexible Elastomeric Foam products with or without factory -applied non-metallic cladding are delivered in prefabricated pipe section, rolls and slabs.	
<b>Application</b>	FEF can be used for instrument tubing with diameter DN≤ 32 mm for all insulation classes for temperatures ≤ 110 °C. FEF can also be used for thermal insulation of piping and equipment for onshore with corrosivity category C4 or lower according to ISO 9223 Annex C.	

**MATERIAL DATA AND PROPERTIES (additional testing and acceptance criteria)**

Standard	ASTM C534/C534M	EN 14304
Maximum service temperature		Section 4.3.2
Minimum service temperature		Section 4.3.3
Density	ASTM D1622	D4
Water absorption		Section 4.3.5
Traces of water soluble ions		Section 4.3.6, Acceptance criteria: Figure 1 in ASTM C795 pH=7-12,5
Reaction to fire		Section 4.2.4, Acceptance criteria: minimum DI-s3,d0

**INSTALLATION REQUIREMENTS**

<b>General</b>	Installation according to installation manual from Manufacturer. For classes 5, 6, 7 and 8, installation shall be done as described in the relevant test reports / installation instructions for the qualified systems.
----------------	--

**PETROBRAS****TECHNICAL SPECIFICATION**

No. I-ET-3010.00-1200-431-P4X-001

REV: H

ÁREA

-


SHEET:

39 of 57

TÍTULO:

**THERMAL INSULATION FOR MARITIME INSTALLATIONS****ESUP****INTERNAL**Replace MDS MW with

MATERIAL DATA SHEET		MDS MW	Rev. 01
<b>TYPE OF MATERIAL: Mineral wool (MW)</b>			
<b>Standard</b> <i>Either ASTM or EN standard shall be used.</i>	<b>Grade / Type</b>	<b>Additional requirements</b>	
ASTM C547 (pipe section)	Type II	Section 11.1.10, ASTM E136 and ISO 12623/ISO29767	
ASTM C553 (mats without mesh)	Type VII	Section 11.9, ASTM E136 and ISO 12623/ISO29767	
ASTM C592 (mats, wired mats)	Type II	Section 11.11, ASTM E136 and ISO 12623/ISO29767	
ASTM C612 (block and boards)	Type IVB	Section 12.10 and ASTM E136 and ISO 12623/ISO29767	
EN 14303		Section 4.2.4 (Acceptance criteria) Sections 4.3.2, 4.3.5, 4.3.7 and B.2	
<b>General</b>	This MDS specifies the selected options in the referred standard and additional requirements which shall be added or supersede the corresponding requirements in the referred standard. Products shall meet the requirements for bio-soluble fibres in Note Q of Regulation (EC) No. 1272/2008		
<b>Products</b>	Mineral wool products are supplied as mandrel wound pipe sections, wired mats, mats and slabs. Wired mats shall be supplied with stainless steel (SS304) stitching wire and mesh in corrosive environments $\geq$ C5 according to ISO 9223 Annex C. Galvanized stitching wire and mesh can be used in corrosive environments $\geq$ C4 according to ISO 9223 Annex C.		
<b>Application</b>	All insulation classes except class 2 and 9. In corrosive environments $\geq$ C5 according to ISO 9223 Annex C and at normal operation temperatures $<$ 180°C, MW shall only be used as part of a non-contact insulation system or used as a secondary (outer layer) insulation material applied over e.g. aerogel.		
<b>MATERIAL DATA AND PROPERTIES (additional testing and acceptance criteria)</b>			
<b>Standard</b>	<b>ASTM C547/C553/C592/612</b>	<b>EN 14303</b>	
Maximum service temperature		Section 4.3.2	
Density		Section B.2	
Water absorption	ISO 12623/ISO 29767, Acceptance criteria: maximum 0,2 kg/m <sup>2</sup>	Section 4.3.5, Acceptance criteria: maximum 0,2 kg/m <sup>2</sup>	
Traces of water soluble ions and pH	Sections 11.1.10, 11.9, 11.11 and 12.10 (ASTM C547/C553/C592/C612)	Section 4.3.7, Acceptance criteria: Figure 1 in ASTM C795 pH-value = 7-12,5	
Reaction to fire	ASTM E136	Section 4.2.4, Acceptance criteria: A1	

 <b>PETROBRAS</b>	<b>TECHNICAL SPECIFICATION</b>	No. I-ET-3010.00-1200-431-P4X-001	REV: H
	AREA: -	SHEET: 40 of 57	
	TITLE:	<b>THERMAL INSULATION FOR MARITIME INSTALLATIONS</b>	
		ESUP	
		INTERNAL	

<b>MATERIAL DATA SHEET</b>	<b>MDS MW (continued)</b>	<b>Rev. 01</b>
----------------------------	---------------------------	----------------

<b>INSTALLATION REQUIREMENTS</b>	
General	Installation according to installation manual from Manufacturer. For classes 5, 6, 7 and 8, installation shall be done as described in the relevant test reports / installation instructions for the qualified systems.



PETROBRAS

TECHNICAL SPECIFICATION

No. I-ET-3010.00-1200-431-P4X-001

REV: H

AREA

-

SHEET:

41 of 57

TITLE:

THERMAL INSULATION FOR MARITIME INSTALLATIONS

ESUP

INTERNAL

Add new MDS PIR

MATERIAL DATA SHEET		MDS PIR	Rev.01
<b>TYPE OF MATERIAL: Polyisocyanurate (PIR)</b>			
<b>Standard</b> <i>Either ASTM or EN standard shall be used.</i>	<b>Grade / Type</b>	<b>Additional requirements</b>	
<b>ASTM C591</b>	Type II	Section 12.9	
<b>EN 14308</b>		Sections 4.3.2, 4.3.3, 4.3.5, 4.3.6.1, 4.3.6.2, 4.3.7, 4.3.8 and D.9	
<b>General</b>	This MDS specifies the selected options in the referred standard and additional requirements which shall be added or supersede the corresponding requirements in the referred standard.		
<b>Products</b>	The products are manufactured in the form of boards, pipe sections, segments and prefabricated ware.		
<b>Application</b>	PIR can be used onshore with corrosivity category C4 or lower according to ISO 9223 Annex C for systems with temperature lower than ambient.		
<b>MATERIAL DATA AND PROPERTIES (additional testing and acceptance criteria)</b>			
<b>Standard</b>	<b>ASTM C591</b>	<b>EN 14308</b>	
Maximum service temperature		Section 4.3.2	
Minimum service temperature		Section 4.3.3	
Density		Section D.9	
Water absorption		Sections 4.3.6.1 and 4.3.6.2, Acceptance criteria: max 1 % (volume)	
Traces of water soluble ions and the pH value		Section 4.3.8, Acceptance criteria: Figure 1 in ASTM C795 pH= 7-12,5	
Reaction to fire	Section 12.9	Section 4.2.4, Acceptance criteria: min DI-s3,d0	
Close cell content		Section 4.3.7, Acceptance criteria: minimum 90 %	
<b>INSTALLATION REQUIREMENTS</b>			
<b>General</b>	Installation according to installation manual from Manufacturer. For classes 5, 6, 7 and 8, installation shall be done as described in the relevant test reports / installation instructions for the qualified systems.		

Delete MDS PBFP



PETROBRAS

**TECHNICAL SPECIFICATION**

No. I-ET-3010.00-1200-431-P4X-001

REV: H

AREA

-

SHEET:

42 of 57

TITLE:

**THERMAL INSULATION FOR MARITIME INSTALLATIONS**

ESUP

INTERNAL

Replace MDS GRP with

MATERIAL DATA SHEET		MDS GRP	Rev. 01
<b>TYPE OF MATERIAL: Weather resistant glass fibre reinforced polymer (GRP) cladding</b>			
<b>General</b>	This specification describes the minimum requirements for a GRP for cladding purposes.		
<b>Products</b>	Laminate based on glass fibre reinforced polyester and/or vinyl ester resins. The material can be supplied as prefabricated shells or as wet material by curing on site.		
<b>Standard</b>	NA		
<b>Application</b>	GRP is used for external areas subjected to mechanical loads or where a water tight cladding is required.		
<b>MATERIAL DATA AND PROPERTIES</b>			
General requirements	The cladding material shall have a maximum material temperature resistance: $\geq 90$ °C.		
	Layer thickness: $\geq 1,5$ mm		
	<b>Standard</b>	<b>Acceptance criteria</b>	
Mechanical properties	ISO 178 / ASTM D790	Bending strength: $\geq 130$ MPa	
	ISO 527 / ASTM D3039	Tensile strength: $\geq 50$ MPa	
	ISO 527 /ASTM D3039	Elongation at break: $\geq 1$ %	
	ASTM D2583	Barcol hardness shall be specified by Supplier	
Reaction to fire	One of the following: ASTM E84 or EN13501-1	Tests shall be documented.	
Aging test	ISO 12944-9 (Exposure cycling test condition)	It shall be documented that the material (including system for joining) will maintain minimum 90 % of its tensile strength/elongation properties after the accelerated aging. The GRP can be tested with or without a UV durable topcoat.	
Additional requirements	Depending on design life and risk for direct sunlight exposure, GRP may be required protected by a UV durable topcoat, with quality in line with topcoat in system 1 (IOGP S-715). The coating can be pre-applied to the prefabricated shells or site applied.		
	GRP shall be antistatic and fulfill the requirements in EN 13463-1:2009/ISO 80079-36 Annex D (except high voltage spray electrode test).		
General	Installation according to installation manual from Manufacturer. GRP cladding shall be pre-cured before installation.		



PETROBRAS

**TECHNICAL SPECIFICATION**

No. I-ET-3010.00-1200-431-P4X-001

REV: H

AREA

-

SHEET:

43 of 57

TITLE:

**THERMAL INSULATION FOR MARITIME INSTALLATIONS**

ESUP

INTERNAL

Add new MDS FEM with reinforcement

MATERIAL DATA SHEET		MDS FEM with reinforcement		Rev. 01
<b>TYPE OF MATERIAL: Weather resistant flexible elastomeric membrane (FEM) with reinforcement</b>				
<b>General</b>	This specification describes the minimum requirements for a FEM for cladding purposes.			
<b>Products</b>	Woven glass scrim reinforced Chlorosulphonated Polyethylene (CSPE) polymeric covering where the CSPE content of the polymer content is greater than 30 %.			
<b>Standard</b>	NA			
<b>Application</b>	FEM is a water proof cladding system designed to prevent water ingress into the insulation material			
<b>MATERIAL DATA AND PROPERTIES</b>				
General requirements	The cladding material shall have an applicable temperature range from -50 °C to + 100 °C.			
	Layer thickness: ≥ 1 mm			
	<b>Test standard</b>	<b>Acceptance criteria</b>		
Mechanical properties	ASTM D751 (Trapezoidal tear test) or ASTM D624 (Trouser tear test) / ISO 34-1 (Method A)	Trapezoidal tear strength (ASTM D751) ≥ 80 N Tear strength (ASTM D624 or ISO 34-1) ≥ 25 N/mm		
	ASTM D751 or ASTM D412 / ISO 37	Breaking strength in machine direction ≥ 10 MPa		
	ASTM D751 or ASTM D412 / ISO 37	Elongation at break in machine direction ≥ 200 %		
	ASTM D751	Puncture resistance ≥ 100 N		
Reaction to fire	ASTM E84 / EN 13501-1	Tests shall be documented.		
Aging test	ISO 12944-9, Annex B (Exposure cycling test condition)	It shall be documented that the material (including system for joining) will maintain min. 90 % of its tensile strength/elongation properties after the accelerated aging.		
Water vapour permeance	ASTM E96, procedure E / EN12086	Acceptance criteria: max 0,001 g/(m <sup>2</sup> ·h ·mm Hg)		
General	Installation according to installation manual from Manufacturer.			



PETROBRAS

**TECHNICAL SPECIFICATION**

No. I-ET-3010.00-1200-431-P4X-001

REV: H

AREA

-

SHEET:

44 of 57

TITLE:

**THERMAL INSULATION FOR MARITIME INSTALLATIONS**

ESUP

INTERNAL

Add new MDS FEM without reinforcement

MATERIAL DATA SHEET

MDS FEM without reinforcement

Rev. 01

**TYPE OF MATERIAL: Weather resistant flexible elastomeric membrane (FEM) without reinforcement**

<b>General</b>	This specification describes the minimum requirements for a FEM for cladding purposes.
<b>Products</b>	Chlorosulphonated Polyethylene (CSPE) polymeric covering where the CSPE content of the polymer content is greater than 30 % without woven glass scrim reinforcement Ethylene Propylene Diene Monomer (EPDM) polymeric covering
<b>Standard</b>	NA
<b>Application</b>	FEM is a water proof cladding system designed to prevent water ingress into the insulation material

**MATERIAL DATA AND PROPERTIES**

General requirements	The cladding material shall have an applicable temperature specified by the supplier in the material data sheet.	
	Layer thickness: $\geq 1$ mm	
	<b>Test standard</b>	<b>Acceptance criteria</b>
Mechanical properties	ASTM D624 / ISO 34	Tear strength $\geq 5$ N/mm
	ASTM D412 / ISO 37	Breaking strength $\geq 4$ MPa
	ASTM D412 / ISO 37	Elongation at break $\geq 150$ %
Reaction to fire	ASTM E84 / EN 13501-1	Tests shall be documented.
Aging test	ISO 12944-9, Annex B (Exposure cycling test condition)	It shall be documented that the material (including system for joining) will maintain min. 90 % of its tensile strength/elongation properties after the accelerated aging.
Water vapour permeance	ASTM E96, procedure E / EN12086	Acceptance criteria: max 0,001 g/(m <sup>2</sup> ·h·mm Hg)
General	Installation according to installation manual from Manufacturer.	



PETROBRAS

TECHNICAL SPECIFICATION

No. I-ET-3010.00-1200-431-P4X-001

REV: H

AREA

-

SHEET:

45 of 57

TITLE:

THERMAL INSULATION FOR MARITIME INSTALLATIONS

ESUP

INTERNAL

Add new Annex E

Annex E
(informative)
Example insulation checklist

This checklist is for typical inspection activities related to installation of insulation.
This checklist can be part of the ITP.

Table with 3 columns: Description, Accepted, date and signature, Comments. Rows include sections for 'Before insulation installation', 'Installation of insulation materials', and 'Installation of cladding' with various sub-items.



PETROBRAS

**TECHNICAL SPECIFICATION**

No. I-ET-3010.00-1200-431-P4X-001

REV: H

AREA

-

SHEET:

46 of 57

TITLE:

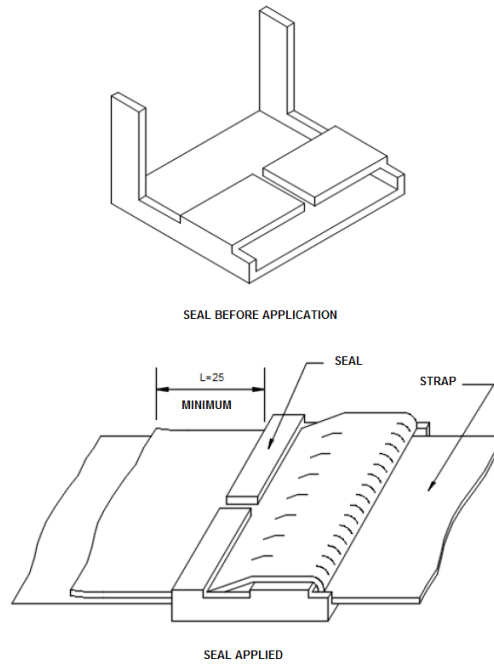
**THERMAL INSULATION FOR MARITIME INSTALLATIONS**

ESUP

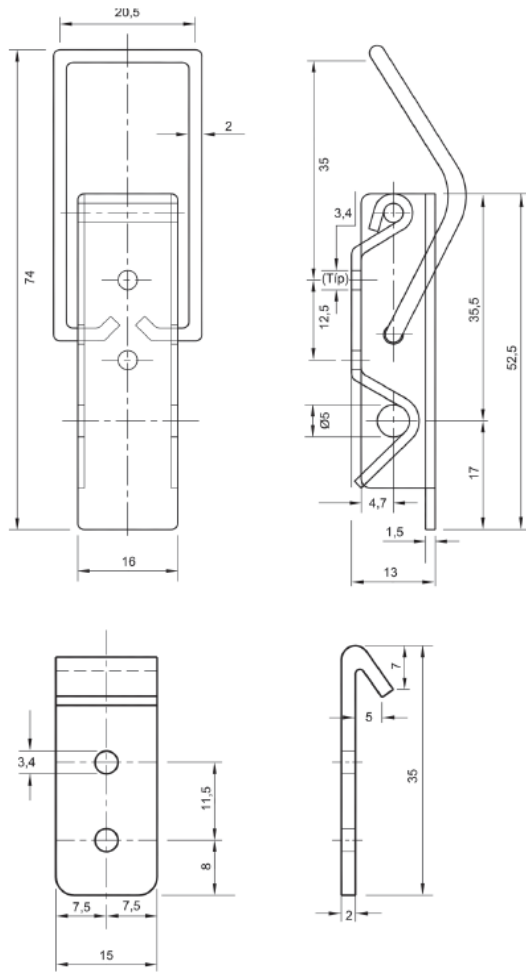
INTERNAL

3.4	Cladding secured according to IPS		
3.5	Sealant applied to avoid any ingress of water		
3.6	Drain holes installed according to IPS		
3.7	Dripping edge installed according to IPS		
3.8	S-clips installed according to IPS (when applicable)		
<b>4.</b>	<b>Boxes and jackets for flanges and valves</b>		
4.1	Allowance for bolt removal according to specification		
4.2	Overlap with pipe according to specification		
4.3	Identification plate according to specification, installed		
4.4	Jackets according to IPS — Insulation material and surface material — Fasteners		
4.5	Removable boxes according to IPS: — Insulation wrapped in aluminium foil — 10° incline on top — Foldout — Drain holes at lowest point of box System without vapour barrier: drain hole through the insulation system System with vapour barrier: drain hole only in cladding: — Minimum 20 mm air cap around flange/valve inside the box, except at penetrations in the box (not for systems with vapour barrier) — Sealing in all penetrations		

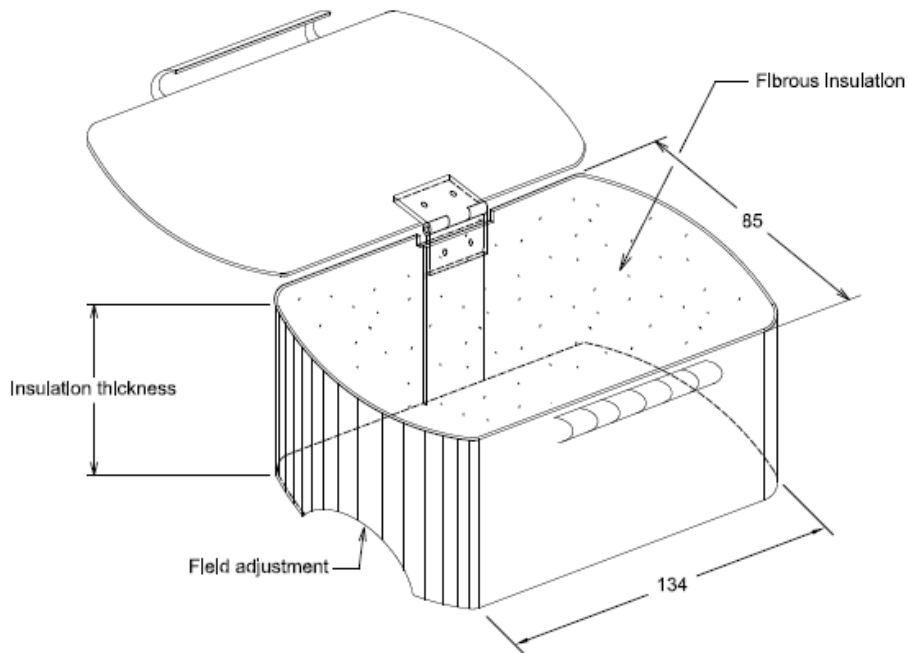
## APPENDIX A – FIGURES



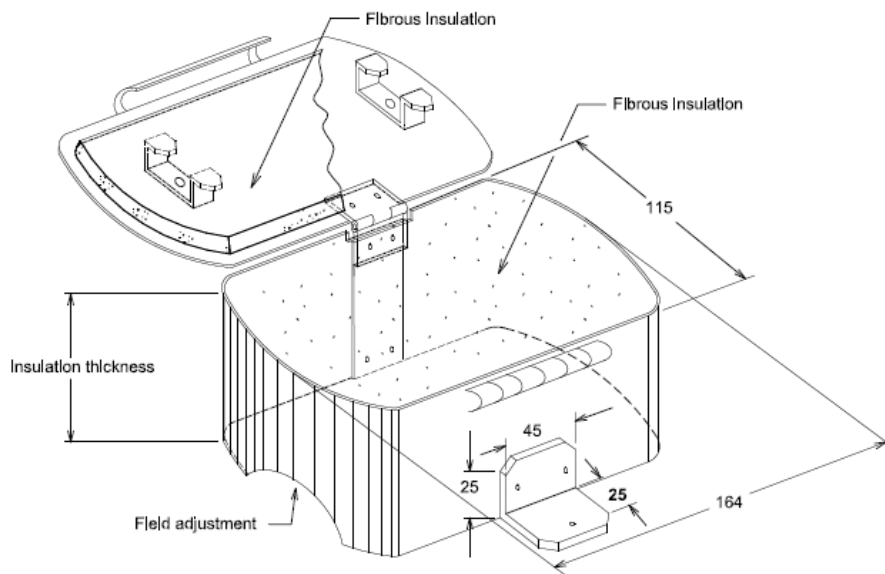
**Figure A.1 - SEAL**



**Figure A.2 - QUICK COUPLING AND CLASP**

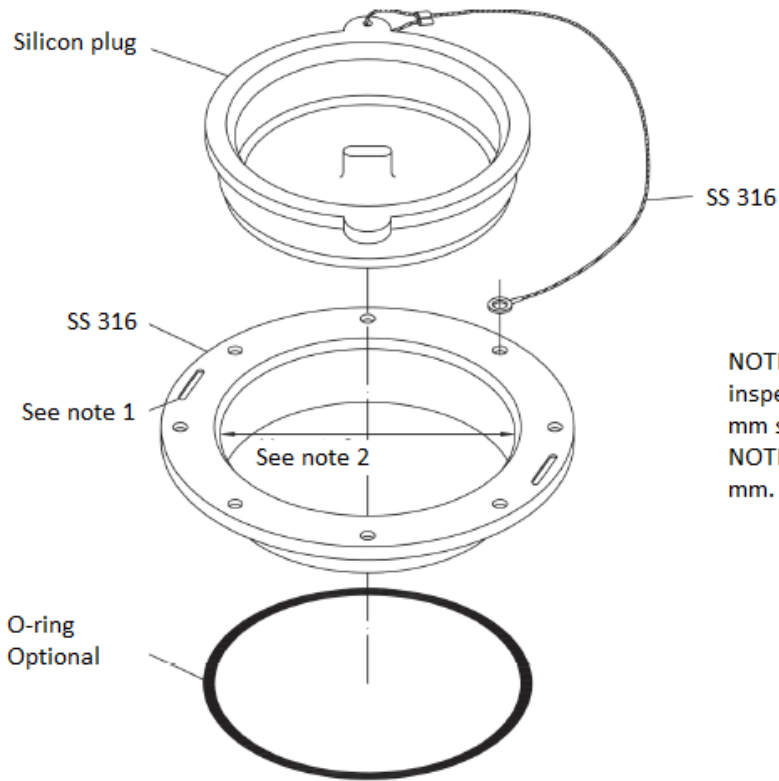


Box for measuring thickness of pipe up to 2 1/2 in nominal diameter



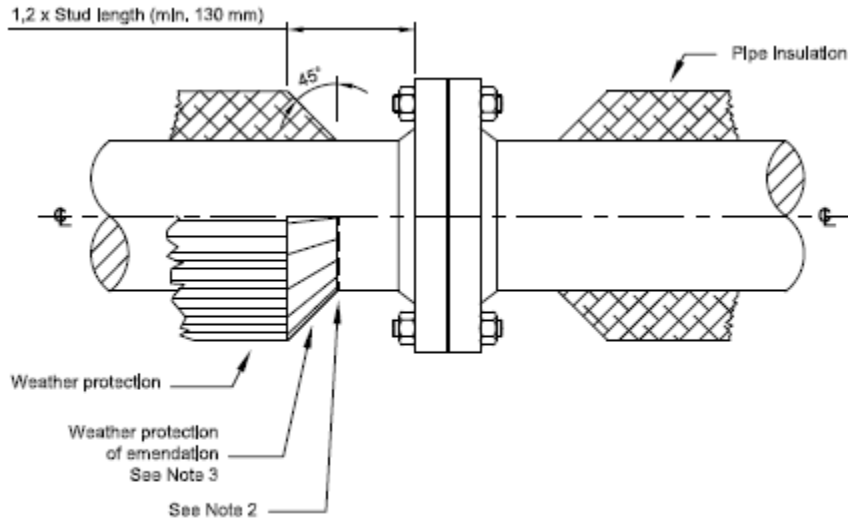
Box for measuring thickness of pipe up to 3" in nominal diameter of larger

**Figure A.3 – INSPECTION WINDOW**



NOTE 1 Oblong hole for fixing the inspection window using a 12.7 mm strap.  
NOTE 2 Minimum opening of 100 mm.

**Figure A.4- INSPECTION WINDOW**

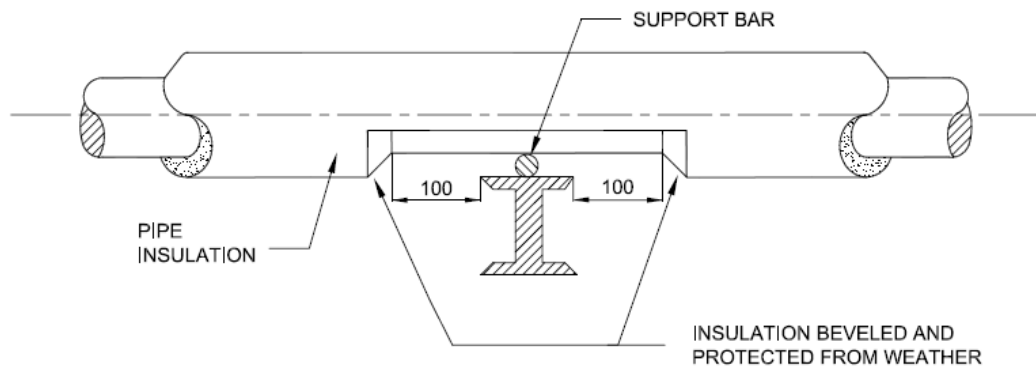


Thermal Insulation of Flanged Connections

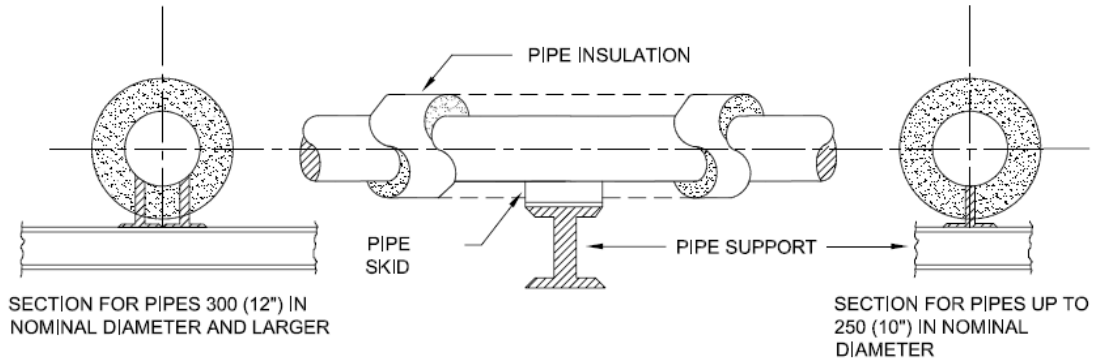
Note 2: Cladding weather protection

Note 3: The thermal insulation close to flanges shall be designed in order to allow the removal of studs and bolts without damage to the insulation.

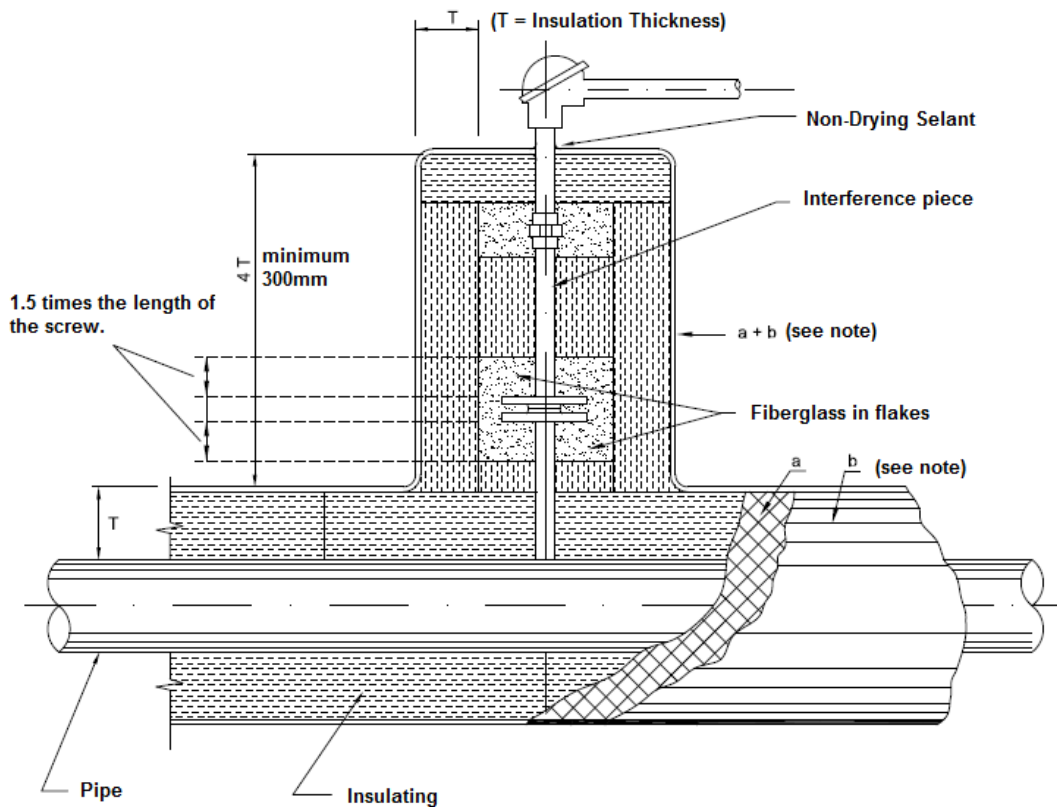
**Figure A.5 - INSULATION OF FLANGES**



**Figure A.6 - PIPING SUPPORTS**

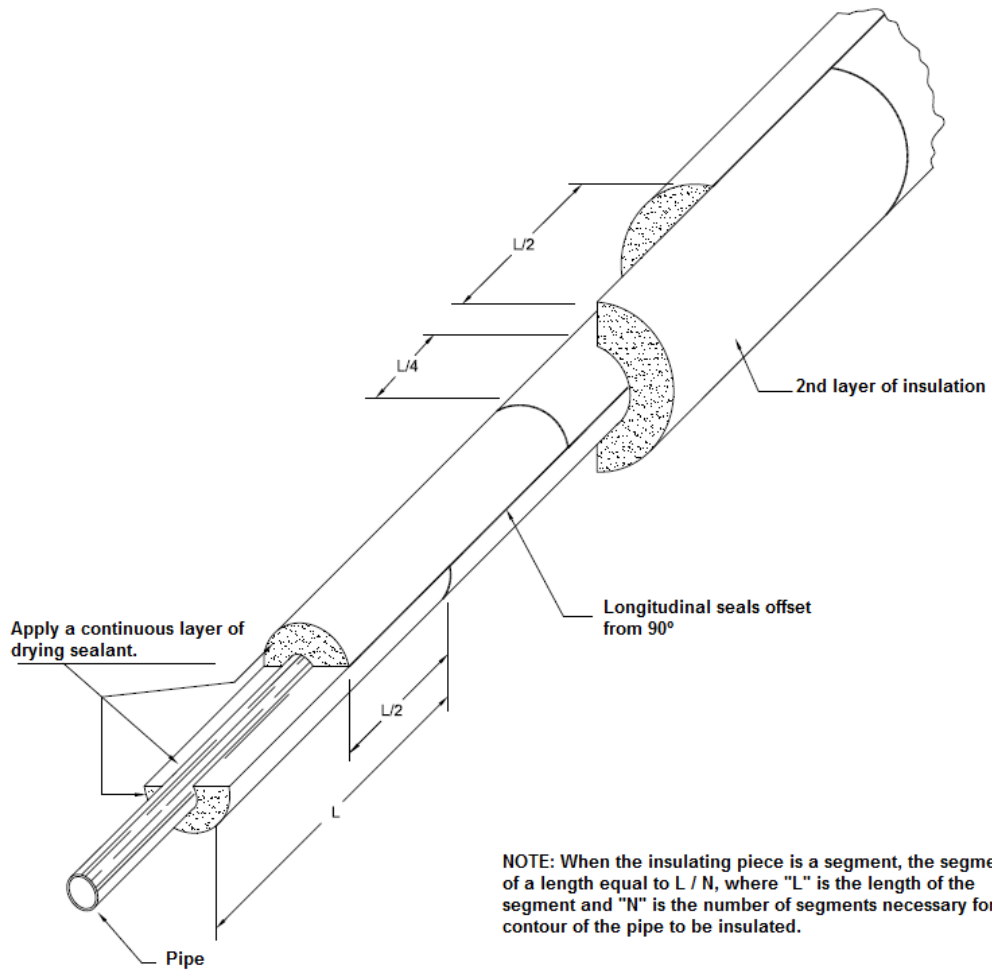


**Figure A.7 – PIPING WITH SHOE**

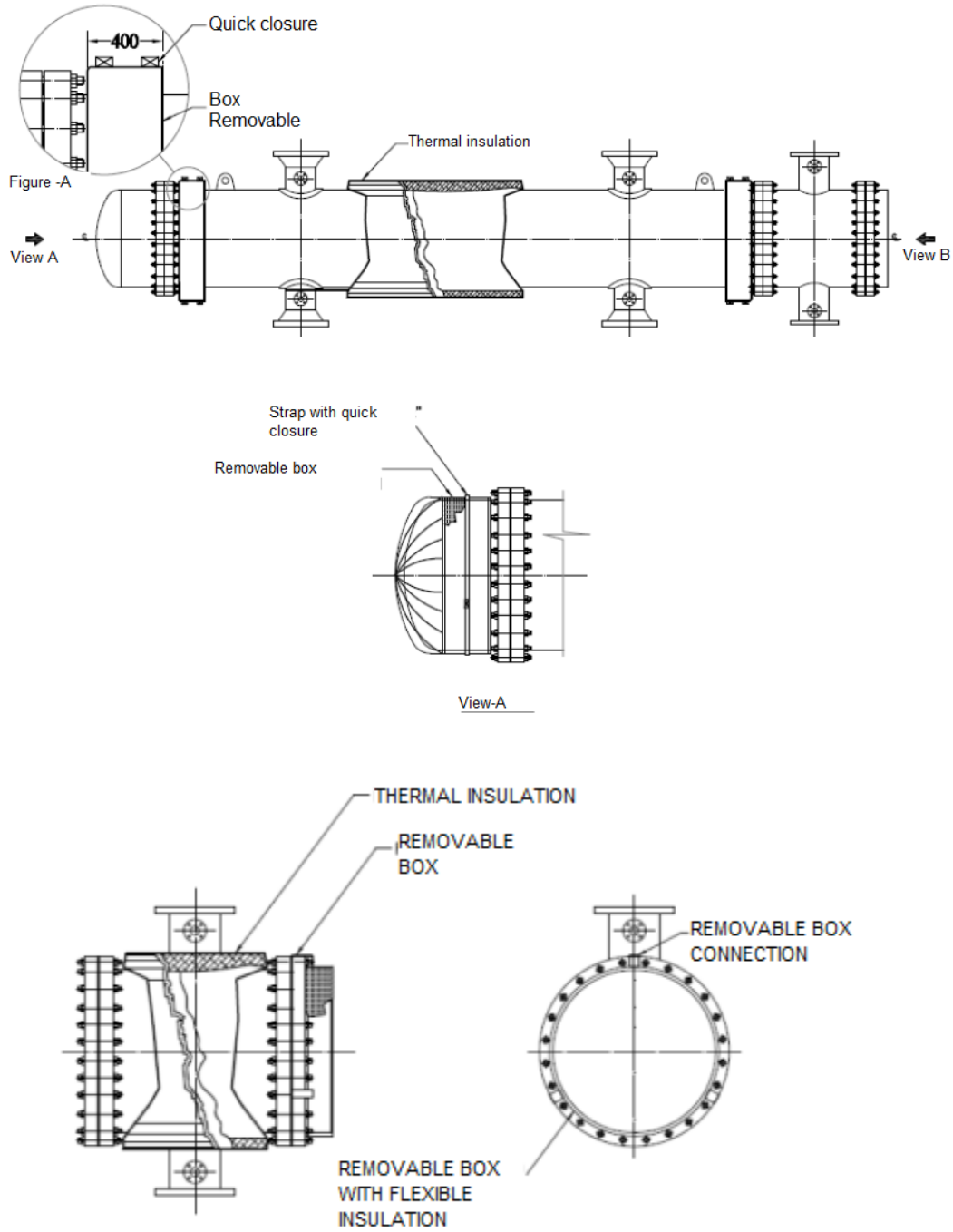


(Note: a = Steam Barrier  
b = Protection against interpeiries).

**Figure A.8- PART INSULATION INTERFERENCE CONNECTED TO PIPE.**



**Figure A 9 - DISPOSITION OF PRE-MOLDED INSULATED PART.**



**Figure A.10 – THERMAL INSULATION OF HEAT EXCHANGER**

## APPENDIX B – REFERENCE TABLES

**TABLE B.1 – Aerogel – Thickness of thermal insulation for hot conservation**

Pipe NPS (in)	Temperature (°C)													
	50	75	100	125	150	175	200	250	300	350	400	450	500	550
1/2"	5	10	10	10	15	15	15	15	20	20	20	20	25	25
3/4"	5	10	10	10	15	15	15	15	20	20	20	25	25	25
1"	5	10	10	15	15	15	15	20	20	20	20	25	25	30
1 1/2"	5	10	10	15	15	15	15	20	20	20	25	25	30	30
2"	5	10	10	15	15	15	15	20	20	25	25	30	30	35
2 1/2"	5	10	10	15	15	15	20	20	20	25	25	30	30	35
3"	5	10	10	15	15	15	20	20	20	25	30	30	35	35
4"	5	10	15	15	15	15	20	20	25	25	30	30	35	40
6"	5	10	15	15	15	20	20	20	25	30	30	35	35	40
8"	5	10	15	15	15	20	20	20	25	30	30	35	40	40
10"	5	10	15	15	15	20	20	25	25	30	35	35	40	45
12"	5	10	15	15	15	20	20	25	25	30	35	35	40	45
14"	5	10	15	15	15	20	20	25	25	30	35	35	40	45
16"	5	10	15	15	15	20	20	25	25	30	35	40	40	45
18"	5	10	15	15	15	20	20	25	25	30	35	40	40	45
20"	5	10	15	15	15	20	20	25	25	30	35	40	40	45
22"	5	10	15	15	15	20	20	25	25	30	35	40	40	45
24"	5	10	15	15	15	20	20	25	25	30	35	40	45	45
26"	5	10	15	15	15	20	20	25	25	30	35	40	45	45 <sup>1</sup>
28"	5	10	15	15	15	20	20	25	30	30	35	40	45	45 <sup>1</sup>
30"	5	10	15	15	15	20	20	25	30	30	35	40	45	45 <sup>1</sup>
32"	5	10	15	15	15	20	20	25	30	30	35	40	45	45 <sup>1</sup>
34"	5	10	15	15	15	20	20	25	30	30	35	40	45	45 <sup>1</sup>
36"	5	10	15	15	15	20	20	25	30	30	35	40	45	50 <sup>1</sup>
38"	5	10	15	15	15	20	20	25	30	30	35	40	45	50 <sup>1</sup>
40"	5	10	15	15	15	20	20	25	30	30	35	40	45 <sup>1</sup>	50 <sup>1</sup>
42"	5	10	15	15	15	20	20	25	30	30	35	40 <sup>1</sup>	45 <sup>1</sup>	50 <sup>1</sup>
<b>Equipment</b>	5	10	15	15	15	20	20	25	30 <sup>1</sup>	35 <sup>1</sup>	40 <sup>1</sup>	45 <sup>1</sup>	50 <sup>1</sup>	55 <sup>1</sup>

Note: For this case the thickness for personnel protection is higher than hot conservation



PETROBRAS

TECHNICAL SPECIFICATION

No. I-ET-3010.00-1200-431-P4X-001

REV: H

AREA

-

SHEET:

56 of 57

TITLE:

THERMAL INSULATION FOR MARITIME INSTALLATIONS

ESUP

INTERNAL

TABLE B.2 - Aerogel – Thickness of thermal insulation for Personnel Protection

Pipe NPS (in)	Temperature (°C)													
	50	75	100	125	150	175	200	250	300	350	400	450	500	550
1/2"	5	5	5	5	5	5	5	5	5	10	10	10	15	15
3/4"	5	5	5	5	5	5	5	5	10	10	10	10	15	15
1"	5	5	5	5	5	5	5	5	10	10	10	15	15	20
1 1/2"	5	5	5	5	5	5	5	10	10	10	15	15	20	20
2"	5	5	5	5	5	5	5	10	10	10	15	15	20	20
2 1/2"	5	5	5	5	5	5	5	10	10	10	15	15	20	25
3"	5	5	5	5	5	5	5	10	10	15	15	20	20	25
4"	5	5	5	5	5	5	5	10	10	15	15	20	25	25
6"	5	5	5	5	5	5	10	10	15	15	20	25	25	30
8"	5	5	5	5	5	10	10	10	15	20	20	25	30	35
10"	5	5	5	5	5	10	10	10	15	20	25	25	30	35
12"	5	5	5	5	5	10	10	15	15	20	25	30	35	40
14"	5	5	5	5	5	10	10	15	15	20	25	30	35	40
16"	5	5	5	5	5	10	10	15	20	20	25	30	35	45
18"	5	5	5	5	10	10	10	15	20	20	25	30	40	45
20"	5	5	5	5	10	10	10	15	20	25	30	35	40	45
22"	5	5	5	5	10	10	10	15	20	25	30	35	40	50
24"	5	5	5	5	10	10	10	15	20	25	30	35	40	50
26"	5	5	5	5	10	10	10	15	20	25	30	35	45	50
28"	5	5	5	5	10	10	10	15	20	25	30	35	45	50
30"	5	5	5	5	10	10	10	15	20	25	30	40	45	55
32"	5	5	5	5	10	10	15	15	20	25	35	40	45	55
34"	5	5	5	5	10	10	15	15	20	25	35	40	45	55
36"	5	5	5	5	10	10	15	20	25	30	35	40	50	55
38"	5	5	5	5	10	10	15	20	25	30	35	40	50	55
40"	5	5	5	5	10	10	15	20	25	30	35	45	50	60
42"	5	5	5	5	10	10	15	20	25	30	35	45	50	60
Equipment	5	5	5	10	15	15	20	25	35	40	50	60	75	75



PETROBRAS

TECHNICAL SPECIFICATION

No. I-ET-3010.00-1200-431-P4X-001

REV: H

ÁREA

-

SHEET:

57 of 57

TITLE:

THERMAL INSULATION FOR MARITIME INSTALLATIONS

ESUP

INTERNAL

## SECTION II – IOGP S-738L INFORMATION REQUIREMENTS FOR INSULATION FOR PIPING AND EQUIPMENT



Quality-Reqs-Insulation-for-Piping-and-Eq

## SECTION III – IOGP S-738Q QUALITY REQUIREMENTS FOR INSULATION FOR PIPING AND EQUIPMENT



Info-Reqs-Insulation-for-Piping-and-Equipm