	TECHNICAL SPECIFICATION		I-ET-3010.2Q-1400-196-P4X-001	
	CLIENT:	MARLIM LESTE E SUL		SHEET 1 of 57
	PROGRAM:	BASIC DESIGN – REVIT I		
	AREA:	MARLIM LESTE E SUL		ESUP
	TITLE:	ERGONOMICS REQUIREMENTS FOR TOPSIDE		INTERNAL

--

INDEX OF REVISIONS

REV.	DESCRIPTION AND/OR REVISED SHEETS
------	-----------------------------------

0	ORIGINAL ISSUE.
A	REVISED ACCORDING TO CONSISTENCY ANALYSIS

	REV. 0	REV. A	REV. B	REV. C	REV. D	REV. E	REV. F	REV. G	REV. H
DATE	JUN/17/24	JUL/22/2024							
DESIGN	ESUP	ESUP							
EXECUTION	BBBA	BBBA							
CHECK	EIG3	EIG3							
APPROVAL	CMYR	ESLS							

INFORMATION IN THIS DOCUMENT IS PROPERTY OF BUYER, BEING PROHIBITED OUTSIDE OF THEIR PURPOSE.
 FORMULÁRIO DA BUYER N-0381 REV.M.



PETROBRAS

TECHNICAL SPECIFICATION

Nº I-ET-3010.2Q-1400-196-P4X-001

REV A

MARLIM LESTE E SUL

sheet 2 of 57

TITLE:

ERGONOMICS REQUIREMENTS FOR TOPSIDE

INTERNAL

ESUP

SUMMARY

1 OBJECTIVE3

2 INTRODUCTION3

3 RULES AND REGULATIONS3

4 SCOPE.....4

5 CARGO HANDLING5

5.1 GENERAL CONSIDERATIONS.....5

5.2 REQUIREMENTS.....7

6 MANUAL ACTUATION VALVES13

6.1 GENERAL CONSIDERATIONS.....13

6.2 REQUIREMENTS.....14

6.3 ANALYSIS TO BE PERFORMED DURING THE DETAILING DESIGN.....29

7 PIG LAUNCH AND RECEIVE SYSTEM.....30

7.1 GENERAL CONSIDERATIONS.....30

7.2 REQUIREMENTS.....30

7.3 INTERLOCK SYSTEM33

8 STAIRS AND ACCESS WAYS33

8.1 GENERAL CONSIDERATIONS.....33

8.2 ACCESS.....34

8.3 STAIRS, LADDERS, AND RAMPS35

9 INSTRUMENTATION48

10 PRESSURE VESSEL49

11 SIGNALING / VISUAL COMMUNICATION50

12 READING DEVICES AND MANOMETERS50

13 LABORATORY51

13.1 GENERAL CONSIDERATIONS.....51

13.2 LAYOUT, FURNITURE, AND EQUIPMENT51

14 ELECTRICAL SYSTEMS54

14.1 PANEL ROOMS55

14.2 BATTERY ROOMS.....56

15 DIVING OPERATIONS.....57

16 VENDOR PACKAGES57



TECHNICAL SPECIFICATION	Nº I-ET-3010.2Q-1400-196-P4X-001	REV A
MARLIM LESTE E SUL		sheet 3 of 57
TITLE: ERGONOMICS REQUIREMENTS FOR TOPSIDE		INTERNAL
		ESUP

1 OBJECTIVE

The purpose of this document is to guide the basic and detailed design teams that will develop the Detail, Construction, and Integration Design, to integrate work and use dimensions in the platform's detailed design. The design shall respect all referenced applicable codes, norms, regulations, and, when appropriate, the Classification Society (CS) regulations, current Ergonomics legislation, and BUYER' internal rules.

2 INTRODUCTION

The Basic Design presents preliminary configuration of equipment position and pipelines. Detail Design Phase shall adjust and detail this configuration in such way to enable the unit proper operation and maintenance.

In further project phases (Detail, Construction, and Integration), the SELLER shall consider Ergonomics studies and demonstrate through **Ergonomics Report** that requirements from "Ergonomic Recommendations for Topsides" are being followed.

Requirements from this document shall be applied in all supplier packages.

The **Ergonomic Work Analysis** (EWA) shall be undertaken by qualified Ergonomics professionals whose qualifications and methods can be evaluated by BUYER. The EWA shall be presented separately by area of analysis.

The **Ergonomics Report** of Detailing Design Phase shall also be undertaken by qualified Ergonomics professionals whose qualifications and methods can be evaluated by BUYER and shall present evidence that the design meets all requirements given in the ergonomic work analysis. The Ergonomic Report can be presented separately, by topic or area.

The final versions of all documents (reports) developed by the SELLER during the detailing, construction and assembly design phases shall also be delivered both in English and in Portuguese.

All requirements presented in this document are mandatory and shall be met. If any of these recommendations are not observed, the Ergonomic Analysis is not undertaken, or the information demanded in the Ergonomic Report is missing, it shall be considered as a reduction of the scope and shall be charged by the Owner that way. The costs of non-compliance will be proportional to the adjustments necessary to correct the work situation.

3 RULES AND REGULATIONS

The following Rules and Regulations shall be considered for the Project development and Ergonomics Report:

- ABS Guidance Notes on the Application of Ergonomics to Marine Systems, 2018,
- ABS Guidance Notes on the Implementation of Human Factors Engineering into the Design of Offshore Installations, 2014,
- ABS Guide for Ergonomic Notations, September 2021,
- ANP Resolução 43/2007, Regulamento Técnico do Sistema de Gerenciamento da Segurança Operacional das Instalações Marítimas de Perfuração e Produção de Petróleo e Gás Natural (SGSO) – National Petroleum Agency Resolution 43/2007, Technical Regulation of the Operational Safety Management System for Offshore Oil and Natural Gas Drilling and Production Facilities,
- ANP Resolução 41/2015, Regulamento Técnico do Sistema de Gerenciamento de Segurança Operacional de Sistemas Submarinos (SGSS) – National Petroleum Agency Resolution 41/2015, Technical Regulation of the Subsea Systems Operational Safety Management System,
- NR-11 – Transporte, Movimentação, Armazenagem e Manuseio de Materiais – *Transport, Movement, Storage and Handling of Materials*,
- NR-12 – Segurança no Trabalho em Máquinas e Equipamentos - *Safety at Work in Machinery and Equipment*,
- NR-17 – Ergonomia – *Ergonomics*,
- NR-35 – Trabalho em altura – *Work at Height*,
- NR-37 – Segurança e Saúde em Plataformas de Petróleo - *Safety and Health in Oil Platforms*,
- NHO-11 – Avaliação dos Níveis de Iluminamento em Ambientes Internos de Trabalho – *Assessment of Lighting Levels in Internal Work Environments*,
- IEC 61892-2 – Mobile and fixed offshore Units – Electrical installations System design - Part 2,
- ABNT NBR 13962 – Office Furniture – Chairs – Requirements and Test Methods
- ABNT NBR 13967 – Office Furniture – Workstation Systems – Classification and Test Methods,
- NORMAM 223/DPC – Normas da Autoridade Marítima para Registro de Helideques – *Maritime Authority Rules for Helideck Registration*,
- ISO 6940 – Textile Fabrics - Burning Behaviour. Determination of ease of ignition of vertically oriented specimens,
- ASTM F1166 – Standard Practice for Human Engineering Design for Marine Systems, Equipment and Facilities, 2013,
- ABNT NBR 16381 Dutos terrestres e submarinos — Câmara de Pig,
- IOGP - Report 454 – Human Factors Engineering in Projects – International Association of Oil and Gas Producers.
- ANP – Nota Técnica nº 10/2023/SSO-CSO/ANP-RJ

4 SCOPE

This document is oriented to the application of ergonomics to the Process Plant-Topsides (Modules and Main Deck region where they are installed) shown in the drawing I-DE- 3010.2Q-1200-942-P4X-002 (General Arrangement).

Therefore, the requirements from this document will be directed to the following aspects:



TECHNICAL SPECIFICATION	Nº I-ET-3010.2Q-1400-196-P4X-001	REV A
MARLIM LESTE E SUL		sheet 5 of 57
TITLE: ERGONOMICS REQUIREMENTS FOR TOPSIDE		INTERNAL
		ESUP

- Cargo handling (including chemical products),
- Manual actuation valves,
- PIG launching and receiving system,
- Stairs and access routes,
- Flow Measurement System (FMS) instrumentation,
- Pressure vessel,
- Signaling/Visual communication,
- Reading devices and manometers,
- Laboratory,
- Electrical system,
- Diving operation,
- Vendor Packages.

5 CARGO HANDLING

5.1 GENERAL CONSIDERATIONS

Cargo handling is performed by a team composed of logistics and transportation technicians, crane operators, and cargo handling assistants. The work involves receiving, loading, backloading, and moving materials in production units and hull areas.

A careful study of loads that shall be transported in the cargo handling routes is needed, considering the devices used and the resources that may be temporarily assigned in low-frequency events to ensure that interventions during operation and maintenance on the unit's various equipment can be performed.

The assembly and disassembly maneuver should be studied for each task in the detailing project, with a basic plan for handling loads in offshore installations. It is applied to inspection work and other corrective maintenance activities that cannot be performed locally.

When developing a Detail Design cargo handling plan, special attention shall be given to the need to implement adaptations, such as: transforming floors and panels into removable parts, installing eyebolts, among others. The complex structure and the offshore facilities suggest that the cargo handling studies in the project should be verified (in a 3D model), observing the possible bottlenecks, narrow curves, level differences, conflicts between monorails, etc.

Due to the uncertainties inherent to the activity in an offshore environment (unforeseen demands, climatic conditions, etc.), there is a constant demand for adaptation of tasks during the operation, depending on the context. The design, therefore, should provide versatile cargo handling capabilities, capable of being used in different situations.

This topic is divided into 3 central parts: (1) the criteria for identifying critical loads, (2) criteria for defining the type of handling, and (3) inherent factors of cargo handling design.

5.1.1 CRITERIA FOR IDENTIFYING CRITICAL LOADS

In addition to the weight of the load, other conditions influence the method and / or handling system to be chosen for each operation, such as:

- Frequency of movement,
- Steps and transfer of devices in the movement,
- The distance that the load shall be displaced,
- Load range / lifting position,
- Physical and chemical characteristics (hazardous materials),
- Load size and shape,
- Handling route geometry and involved elevations,
- Facilities Access available,
- Environmental conditions (wind speed, sea conditions, etc.).

5.1.2 CRITERIA FOR DEFINING THE TYPE OF MOVEMENT

For safety reasons, handling methods shall be defined according to the weight range, following the specifications of the cargo handling specific document: I-ET-3010.2Q-5266-630-P4X-001 (TOPSIDE'S MECHANICAL HANDLING PROCEDURES).

In specific critical situations, according to the criteria presented in item 5.1.1, mechanical or automated handling can be defined for lighter equipment than those determined in the presented criteria.

Also, aspects such as load movement frequency, grip quality, distance from the body axis, initial and final load height, and load asymmetry shall be considered to determine appropriate movement means.

5.1.3 INHERENT FACTORS OF CARGO HANDLING DESIGN

Cargo handling design shall be based on the interaction between three central factors:

- Equipment design - Determines which are the most suitable means to carry out the movement of materials through flows. Material handling equipment will allow the removal of cargo from one place to another through the determined flows.
- Areas and spaces design - Determines the quantity, positioning, dimensioning, and characteristic (a) of the load areas, (b) the transfer areas, (c) process spaces and accommodations, (d) the equipment arrangement, and (e) escape routes.
- Flow and access design - Provides a procedural view of main equipment movement in the process plant. This factor determines the route taken by the equipment to its final destination. Such a factor shall consider routes' dimensions and intervals, the main flows, and the interfaces between different spaces.

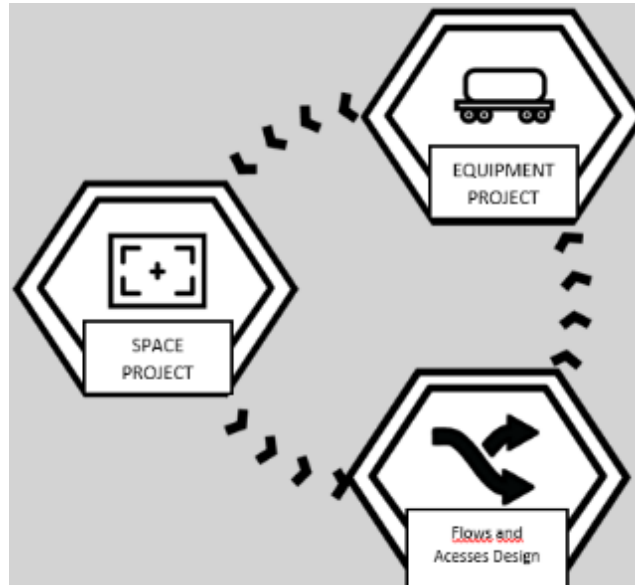

Figure 1. Determining factors of cargo handling design

These factors are the three main resources offered by design. The cargo handling team will mobilize them during unit operation. These three factors shall be integrated to be undertaken: i.e., to build a route with integrated spaces and interfaces and means available for carrying out the maneuver.

5.2 REQUIREMENTS

Cargo handling system design demands an analysis of the requirements specified by the module and equipment suppliers in its different stages, in addition to consulting the cargo handling document: I-ET-3010.2Q-5266-630-P4X-001 (TOPSIDE'S MECHANICAL HANDLING PROCEDURES).

In this specification, general directives for cargo handling system design and guidelines for the main parts of the system, central to the operation, will be presented.

5.2.1 EQUIPMENT

In this item, the guidelines for unit's equipment design will be presented. Due to the importance of cranes for cargo handling system, its guidelines will be given separately. Then the guidelines for the other equipment will be presented.

The main guidelines for cranes are:

- For the purpose of this ET, the provision of two lattice boom cranes is considered. The main crane will be considered the one located near the main laydown area.
- Provide floodlights directed to the laydown areas for making crane operator work easier at night. These floodlights, however, shall be configured in such way to avoid glare from the crane operator's view. Lighting level shall meet requirements of I-ET-3010.00-5140-700-P4X-008 – Specification for Lighting and Electrical Signaling for Offshore Units and I-ET-3010.00-5140-700-P4X-001 – Specification for Electrical Design for Offshore Units.
- Provide alternative access to the crane's control cabins through the process plant.

- For the stairs at the main and alternative accesses to the crane's control cabin, the steps shall be designed with standard dimensions, such as item 8.3, and with nonslip materials, avoiding falls on the way down. One of the accesses shall be through a neighboring module, without the need to climb by vertical ladder.
- The controls in crane cabins shall facilitate access, easy and safe handling, and visibility of process information.
- Crane cabins design shall be in accordance with ASTM F-1166.

The main guidelines related to equipment design are:

- A high-capacity deck trolley that allows the bow-stern movement of the main plant equipment which have no direct access to the cranes is foreseen. The deck trolley shall have direct access to both cranes and enable the internal mobility of the most critical equipment. Finally, it is desirable, especially for very heavy equipment, that the trolley accesses the equipment directly in the module, reducing the number of transfers between devices.
- For everyday drives on the main deck, carts with greater travel flexibility are preferable.
- Provide carts that can overcome small elevations for everyday use.
- Check solutions of articulated devices, which can be decisive in the offshore environment due to their ease of displacement.
- Provide devices suitable for the offshore environment, with locks and explosion-proof whenever necessary.
- Provide carts for the movement of barrels, gas cylinders and jerrycans.
- Provide good diversity of mobile devices (manual hoists, mobile davits, among others), capable of being used in various locations in different situations, always compatible with the cargo weight.
- Provide structures for the installation of mobile devices. For the hoists, for example, provide monorails and eyebolts. For mobile davits, provide fixed bases for installation.
- Provide appropriated room for the parking/ storage of carts, trolleys and other mobile handling devices not to suffer from the effects of rain and salinity.
- Provide, when possible, articulated lifting platforms for installation and uninstallation of mobile devices. The use of this device allows the gain of time and workforce, as it eliminates the need for assembly and disassembly of scaffolding and reduces the exposure of equipment to the weather's action.
- Provide auxiliary lifting devices, such as mobile gantry cranes, spider cranes (or other floor cranes), among others. Such devices are versatile for maneuvers unforeseen in the platform design or whose characteristics have been modified in the execution. The main feature of these devices should be accessibility.

5.2.2 AREAS AND SPACES

This topic will address the main areas related to cargo handling: (1) laydown areas, (2) chemical areas, (3) food receiving areas, and (4) waste containers.

Areas shall be compatible with operational needs and shall have bumpers resistant to load impacts.

LAYDOWN AREAS:

- Provide a main laydown area with access to the main crane and the central route of the process plant.

- Provide an alternative cargo receiving area with access from another crane to enable operations when it is not possible to use the main area or crane.
- Floor shall be made of reinforced wood (for naval use, with anti-flame treatment) or other material that resists containers' impact.
- Deck between main laydown areas and adjacent cargo handling route shall be as leveled as technically feasible to avoid breakage of the cargo handling equipment and to avoid operator fatigue or musculoskeletal disorders.

CHEMICALS STORAGE AREA:

- Design shall provide a chemicals storage area accessed by the same crane that accesses the main laydown area, whenever possible.
- The chemicals area shall have a support for storing different products containers / skids. The structure shall be designed according to the volume and loads of products received.
- The chemical tote tanks in use, meaning those connected to the manifolds, shall be aligned stern to bow. The connection shall be in stern orientation, to allow the chemicals to be fully used.
- Also, the tote tanks shall be placed over supports to allow the easy connection of the hoses with enough space for operators to access the drainage points. Those supports can be one elevated platform or separated ones, depending on the optimization of area.
- If one single support for various tote tanks cannot be adopted, another possible solution is the use of individual supports ("cradles") for containers/ skids of chemicals with mobile supports, and that allows to adapt the support to the size of the container. For these cases, insert a ratchet-type stretcher for locking tanks/refills.
- The platform or the individual supports shall have an inclination (lower at stern) to help drainage the entire content of the tote tanks.
- Detail and inclination of the supports shall be checked during detail design. The inclination of the supports provided shall favor the complete drainage of the container, considering the inclinations foreseen for the unit. At the same time, the supports shall prevent the containers from slipping.
 - Inadequate inclination may prevent the complete drainage of the container, since this feeding is done by gravity,
 - Check size (width and depth) of cradles in relation to containers. It's necessary to have some clear space for maintenance and handling of tote tanks.
 - Study possibility of including guide structure, or free space to improve cargo handling.
- Platforms shall allow the placement of different sizes of tote tanks.
- Enough and proper space shall be assigned to keep the hoses of different products stored when not in use. The most appropriate position is near the valves for coupling to the tanks.
 - For hoses longer than 2 m, horizontal arrangement of hoses is desirable.



Figure 02. Support for hoses

- Provide a solution for the differentiation between the hoses for coupling between containers and tanks. The hoses shall be of dedicated use for each type of product to prevent exchanges between products and incidents when mixing two different products, allowing them to react with each other.
 - The development of specific coupling systems for each type of product shall be implemented.
 - Check possibility of using different color for each type of chemical product, in addition to identification tags.
- Check and guarantee access to vents of tote tanks and lid of other tanks.
- Check the lighting level provided for the Chemical Products area. The activity of filling station is performed mainly at night, so proper illumination shall be provided.
 - Illumination design shall avoid glare and allow good visibility at all areas.
 - Special attention to shaded areas (for example opposite to light side of containers).
- Floor plate shall be anti-slip type without painting. The anti-slip properties shall be inherent of material type.
- Check access to filters for its cleaning. Check visual access and illumination to calibration pots, to test fluid flow. As the area is limited, logistics should adopt a management system that allows use optimization of chemicals deck space. Inventory priority should be given for products that have continuous use or that require immediate replacement, and thus prioritize inventory maintenance to satisfy the demands of processes that cannot fail.

FOOD RECEIVING AREA:

- Specific cargo handling devices shall be foreseen for transportation of food between main laydown areas and parking space for food containers.
- The design shall foresee a food receiving area with easy access to the platform's food storage room.
- Two options of parking for food containers shall be foreseen, as figure below, so Unit's operation can have flexibility to adjust activity considering team and/or cargo handling equipment availability and logistics:

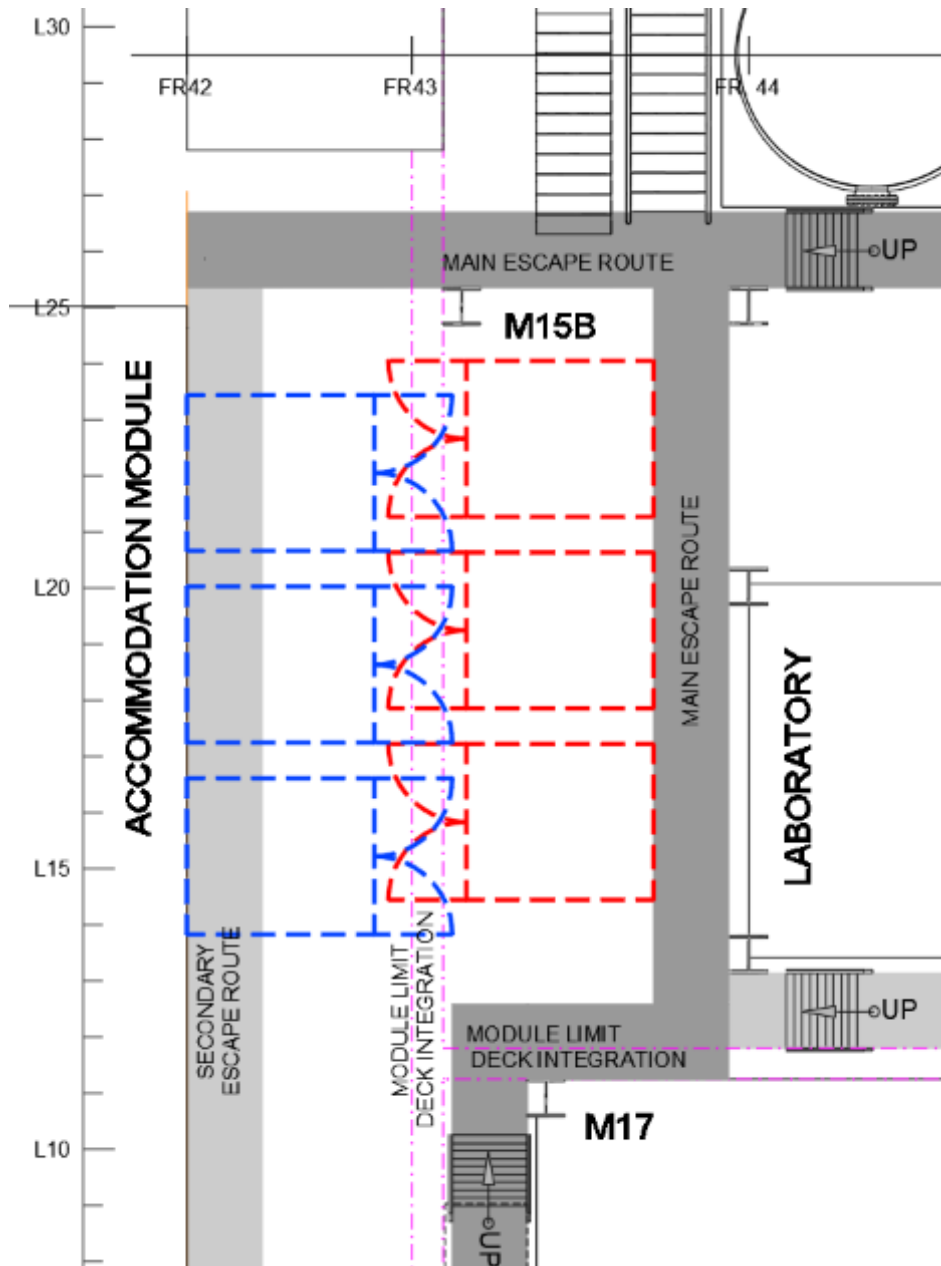

Figure 03 – Parking of Food Containers Alternatives

- Electrical sockets with easy access and the connection shall be provided for refrigerated and frozen food containers, for both positions, in a place where avoids (1) the impact of loads, (2) the people movement flow, and (3) the food movement.
- It is desirable that the area reserved for receiving the food is not used for handling of chemicals or any other type of fluid or material that may contaminate the food.

WASTE AREA:

- Waste area shall be foreseen in the detailed design, its sizing and availability of containers to remove waste from the platform. Waste area shall be detailed according to applicable rules, regulations and laws. Handling plan shall consider devices and distances to be traveled between temporary storage and final removal from platform.

TECHNICAL SPECIFICATION	Nº I-ET-3010.2Q-1400-196-P4X-001	REV A
MARLIM LESTE E SUL		sheet 12 of 57
TITLE: ERGONOMICS REQUIREMENTS FOR TOPSIDE		INTERNAL
		ESUP

GAS CYLINDERS:

- Area for storing spare and empty gas cylinders shall be detailed according to applicable rules, regulations and laws.

5.2.3 ROUTES: FLOWS AND ACCESSES

- The width, free height, and structural capacity of the pathways shall be compatible with the loads and devices that will pass through them.
- Pathways should be straight and flat whenever possible on all material handling routes to make the motion of devices and people easier.
- Prioritize plans with minimal need to change devices during the execution to minimize risks of accidents.
- Basic Design foresees a central pathway that connects the platform from the bow to the stern, at the first level of topside. The pathway dimensions should allow the passage of the main loads moved on the process plant (including containers if there is no direct connection between cranes).
- Due to the existence of pipes, there cannot be a central pathway at *main deck*. A pathway that surrounds the plant should be designed with as little interference as possible. The width and structure of this pathway shall support all equipment planned to move through it. Also, intermediary crossing pathways between starboard and portside shall be provided to make material handling easier in these locations.
- It's foreseen an interface point between the topside and the main deck. A fixed area from laydown to main deck.
- Coamings in Main Deck shall be detailed in such way that favors cargo handling continuous routes.
- Basic Design foresees an elevated stern-bow pathway that facilitates material handling on the higher floors of the topside modules. The design of this pathway shall consider the weight and width of equipment which will be moved there and should be accessed by both cranes.
- Provide interconnection between the topside and the other areas of the unit (accommodation module, forecastle, among others), with easy access for carts, without stairs.
- Provide maintenance routes for topside modules that allow for the equipment removal indicated in the handling plan and their movement to the final destination.
- Obstacles on cargo handling routes shall be avoided. In case there is an obstacle, a ramp shall be provided according to the guidelines. The ramps shall be removable to allow painting repair under them.
- Appropriate method and material handling resources shall be provided to move materials from the helideck, allowing to move equipment above the limit of manual handling (mobile or retractable resources, freight elevator, skip hoists, etc.), if applicable.
- Provide routes that allow the handling of materials to the internal areas of the hull (workshops, engine room, warehouse, among others).
- When hoists, monorails, and/or overhead cranes are used, ensure that the route allows the equipment to pass without interference. The height between the monorail and the equipment to be moved shall consider the height of the installed hoist and a lifting margin, taking into account any restrictions on the installation site.
- When defining the integration level between modules, cargo handling and safety shall be variables to be considered. While the separation between modules brings safety by avoiding oil accumulation and ease in the isolation of areas, the integration brings facilities

to the handling system. An equilibrium point shall be sought so that both demands are met.

- Equipment manholes access type, permanent or temporary, shall be defined during Detail Design, including the provision of any possible scaffolding spaces.

5.2.4 GUIDELINES FOR SPECIFIC MOVEMENTS

- It should be considered the complete replacement of medium and large equipment, such as power transformers, compressors, pumps, large electric engines, turbines, heat exchangers, pressure vessels, large diameter valves, and other equivalents, as well as their main components, when defined by the specific discipline.
- If a submerged pump system is used on cargo tanks, support devices should be provided to remove these pumps for maintenance.
- There shall be a device to move equipment and containers from the laydown area to the diving area.
- Provide free access around flanges (filling station) to receive liquid bulk and make access to the ends of the hoses easier.
- Provide access and material handling resources to the engine room.
- Provide resources for moving materials between the production deck and the main deck.
- Provide means for moving cylinders inside containers (CO₂, for example), which require periodic maintenance.

5.2.5 ANALYSIS OF CHEMICALS HANDLING FOR USE AND REMOVAL OF WASTE

For safety, control of areas, and space organization, the chemical storage deck shall be separated from other areas by bumpers.

The chemical storage deck should be positioned at a high level, allowing products to be moved to the lines by gravitational force.

The same crane that accesses the laydown area shall access the chemical storage area, making logistics easier, whenever is possible.

The chemicals module shall allow drainage of products in case of leaks (e.g., number and types of drains or drain points), considering platform's inclination.

6 MANUAL ACTUATION VALVES

6.1 GENERAL CONSIDERATIONS

Valves are among the main mechanisms used to control the process of a platform. They should have their installation, operation and maintenance facilitated, increasing safety and avoiding ergonomic problems, such as:

- Access difficulties,

- Improper postures,
- Restrictions to hold the handwheel or lever throughout its handling,
- Excessive physical efforts to open or close the valve.

There is a great diversity of types and models in a chemical process facility, its amount is of the order of thousands in offshore units. Therefore, it is necessary to establish criteria to categorize them prioritizing access to emergency valves and frequently used valves.

In addition to these criteria oriented to operators' activity, other specific criteria should be considered to facilitate accessibility for disassembly and assembly of valves, also considering the use of cargo handling equipment according to valve size.

In the following items, guidance will be provided on how to classify valves based on their use and function, indicating some recommendations for the design to provide an appropriate installation for operation, inspection, maintenance, and lubrication of valves.

The following guidelines are derived from standards and prescriptions, in particular ABS (2018) and API 6D (2017), and analyses in reference situations. They have the purpose of assisting in the projects but are limited and do not eliminate the need for analysis in the different modules of the process plant and its particularities such as oil treatment, sulfate removal, removal of CO₂, among others, as well as described in this ET for PIG module.

The ABS (2018) and API 6D (2017) standards have other guidelines and recommendations not mentioned in this ET but can be consulted and used according to the project's needs.

The SELLER shall foresee, in the project schedule, specific 3D model verification events (Design Review) to check compliance with the valve access requirements, with the participation of the SELLER's team of ergonomists and representatives of the BUYER's operating team. These events shall be performed at the 60% and 90% completion stages of the detailing design phase.

6.2 REQUIREMENTS

6.2.1 GENERAL ASPECTS AND PROVISION

For the valves required by function or design to be easily accessible, the valve or its control shall be:

- Installed in a location that typically does not require the use of auxiliary resources,
- Clear of and protected from obstructions, moving equipment, and hot surfaces that may prevent or delay operation or maintenance,
- Within arm's reach. The range area is recommended according to the category classification shown below.

The valves shall be located so that the operator or maintainer does not need to stand or cross over pipes, cable trays, handrails, equipment, or any object that is not specifically intended to be used as a standing surface for the operation, maintenance, repair or replacement of any valve.

In Figure 4 we observed valves in a chemical skid installed in a place where access and permanence on top of pipes and equipment are required during handling or maintenance.



Figure 4. Valves installed in a place where access requires permanence on pipes and equipment.

The floor or standing surface in the handwheel access area shall be flat and have a nonslip surface. Ensure supports with adherence, allowing proper posture to the operator.

Figure 5 shows that the operator needs to partially stand on the top of the vessels to access the equalization valves of the gas dehydration vessels (molecular sieve).



Figure 5. Irregular surface (top of vessel) to valve access support.

According to ABS, a 75 mm free zone should be provided between the outer rim of a valve handwheel, or the end of a valve lever and any obstacle located along with the handwheel, or lever's displacement area. Valves should not be mounted in positions where stems on handwheels or levers will extend into normal walking areas.

Figure 6 shows that the distance between the valve and the pipe does not respect the minimum distance required to operate the handwheel nor the area required for proper positioning of the operator.



Figure 6. Lack of space around handwheel and inadequate valve position does not allow operator access.

Valves used for emergency operations shall not be located below the deck gratings or behind the covers. If it is essential to set the valves behind the covers (e.g., to meet a regulatory requirement), the cover should be opened without the need of tools or the removal of safety fasteners. The cover shall be clearly labeled to identify the valve.

Valves should be supplied with an indicator to determine position. The Indicator shall be installed in such a way as to allow the operator or maintainer to view it from the body position required to open or close the valve.

For valves that require monitoring of process variables during operation, the arrangement of the indicator displays should allow reading from the operator's position. The purpose is to allow a proper posture to the operator.

The valves of the removal system are obstructed by the module support beams. The IP indicators, which workers shall observe during the maneuver, were installed far from the valve.



Figure 7. Module support beams restrict access to valves and location of the IP indicator concerning the valve.

The handwheel diameter shall not exceed 1016 mm The radius shall not exceed the perimeter of the handwheel (API 6D, 2017).

For valves that do not have access by the load handling system defined for platform maintenance, devices shall be provided to enable movement and maintenance, such as handle, monorail, winches, etc.

No valve should be installed where it can obstruct and/or damage escape routes, maintenance routes, and walkways.

For the same valve, the handwheels can be in different positions (upper, lower, lateral with greater or lower inclination). The design should clearly indicate in which position it leaves the handwheel in the ergonomic access zones.

Provide remote-operated mobile devices, such as extensions or valve handwheel stools positioned at or below the floor level (Figure 8 - the purpose is to facilitate access and allow a proper posture to the operator).

The use of chains in the operation of valves is not allowed, as they require high maintenance due to corrosion. Extenders or other devices shall be used instead.



Figure 8. Mobile device to operate valves positioned below the floor.

For ABS (2018), the physical effort applied to handle category 1 and 2 valves should be 100 laps maximum, at a rate between 15 and 60 rotations per minute. When this parameter cannot be followed, a machine shall be provided for rotating manual valves (pneumatic, hydraulic or electrical). This machine shall not exceed 20 kg.

Knurling, indentation, high friction covering, or a combination of these should be used to make force application by the operator easier (ABS, 2018).

Valves in category 1 shall be accessed from permanent structures, elevated or not. Valves in category 2 can be accessed through portable devices that can be shared with other valves, as long as there is a device to each deck. The transportation of devices through different deck elevations is not allowed.

Those portable devices shall follow the orientation guidelines for stairs and access ways, in item 8.

6.2.2 VALVE CATEGORIES

According to their level of criticality, functions, and frequencies of use, valves can be classified into three categories, according to ABS (2018). Categories 1 and 2 are presented in Table 1 as well as their examples.

Table 1. Examples of valves

	Characteristics	Examples of Valves by Category
CATEGORY 1	<p>Valves used in normal and/or emergency operations for the production process, utility systems, marine systems, accommodation, personal and environmental safety. Critical valves involving safety and/or operation during an emergency. Valves are generally used in routine maintenance (once every semester). Essential valves for the unit involving personnel and process safety, load protection, and environmental protection. Valves where the probability of failure is high and can cause severe damage to people, processes, productivity, and the environment</p>	<p>All SDV and BDV valves, All control valves¹ of the production system (system 1223) upstream of the water separator (SG-1223001), Shut-off valves of the service system in wells (system 5133), Block valves (systems 1210, 1231, and 1244) contained in the design that also includes the PIG release and receiving equipment (LP, RP, or LR), All HV, XV, TV, PV, FV, and LV including not only control valves but also by-pass, drains, and block valves, Manual type BDVs valves for compressors, separator vessels, glycol, fuel gas, wells, produced water system, and open drainage, Compressor <i>shutdown</i> valves, Collection system and valves adjacent to it (oil, gas, and water), All block valves adjacent to the input filters of the slop tanks (FT-5336), Upstream and downstream block valves of PSVs, All block valves adjacent upstream and downstream of pumps, Quick-closing block valves of fuel for diesel tanks, All firefighting systems block valves (systems 5423 and 5424).</p>
CATEGORY 2	<p>Non-critical valves for normal or emergency operations, used in a maintenance period of six months or more.</p>	<p>Valves of the sanitary treatment unit (systems 5310, 5311, or 5312), Condensate drain valves (systems 1210, 1225, 1231, 1233, 1234, 1238, 1244, 1252, 1253, 5135, 5412 and Compression Units), Valves for service oil (5139 systems and other systems can be included after detailed design), Battery limit valves (input and output of production modules), Manual valves for normal production start and shutdown operation (XVs and SDVs manual by-pass valves).</p>

1 Block valves are all types except the manual and checking globe/needle.

2 Consider the system as being all valves that contain the system in your TAGs.



TECHNICAL SPECIFICATION	Nº I-ET-3010.2Q-1400-196-P4X-001	REV A
MARLIM LESTE E SUL		sheet 19 of 57
TITLE: ERGONOMICS REQUIREMENTS FOR TOPSIDE		INTERNAL
		ESUP

Category 3 valves are those used in particular circumstances, in rare or low-frequency situations (ABS, 2018). Examples of valves normally included in category 3 are:

- I. Valves used only in the dry dock,
- II. Valves used in initial commissioning,
- III. Valves used for decommissioning,
- IV. Valves used to isolate pressure vessels, tanks, etc., for inspections,
- V. Valves for pressure testing.

Exceptions may be made regarding the placement of valves by category, however each case shall be discussed with the BUYER's Ergonomics team. Four exceptions identified in previous projects are:

1. Drain lines: for definition, drain lines will have lower positions. Nevertheless, unobstructed access shall be provided as well as space under the drain to position sample bottles and clearance for the operator access. Sample bottles shall be represented in 3D model to guarantee feasibility of sample collection, when necessary.
2. Vent valves: for vent valves, unobstructed access shall be provided, however the height restriction by the valve category is not mandatory, as it is not technically applicable due to the installation requirements of this type of valve.
3. Fire-fighting system hydrant connection valves: unobstructed access shall be provided, however, since these valves are only accessed for maintenance, height may be within category 2 range, even if they are a component of safety system.
4. Check valves can be considered in Category 3.

Valve Positioning for Handling and Operation

The recommendation regarding the location of valves occurs according to the range of anthropometric mean, according to the ABS (2018). The valve handwheels should be located as shown in figures 9, 10, and 11, as appropriate for the valve's orientation stem in the vertical, horizontal or inclined position.

It is not recommended that category 1 valves be installed outside the indicated locations. However, category 2 valves can be installed at the category 2 or 1 location.

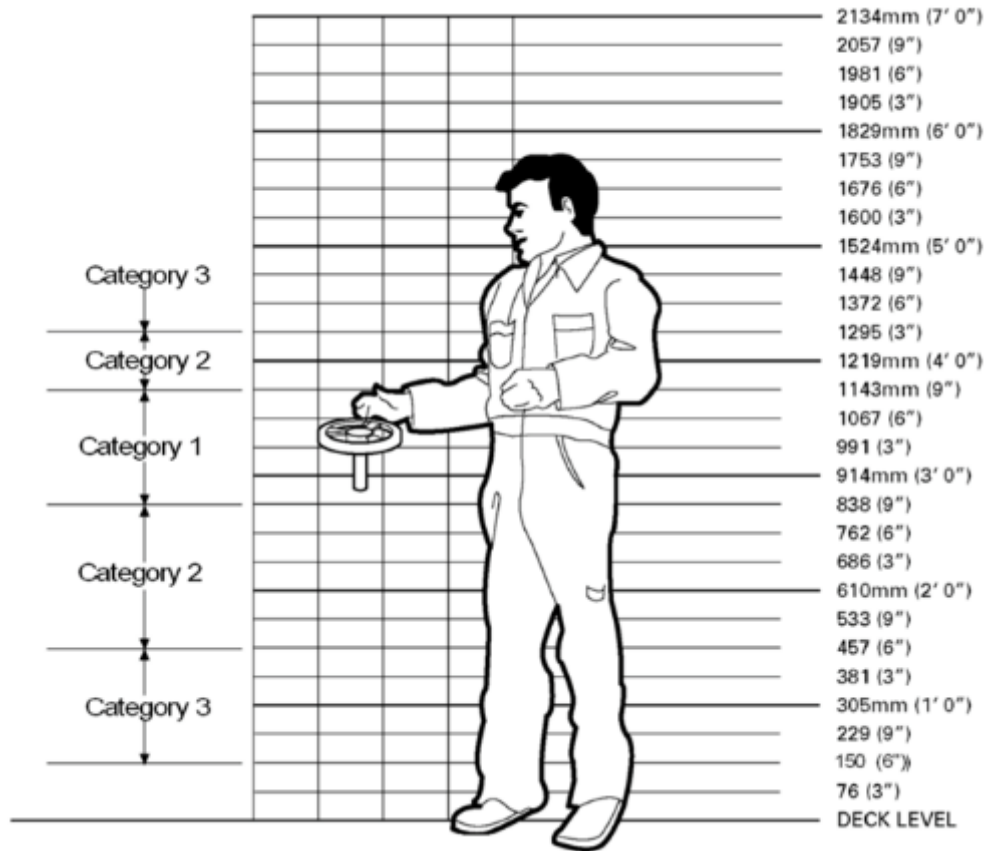

Figure 9. Mounting heights for Handwheel valves with vertical stems (ABS, 2018).

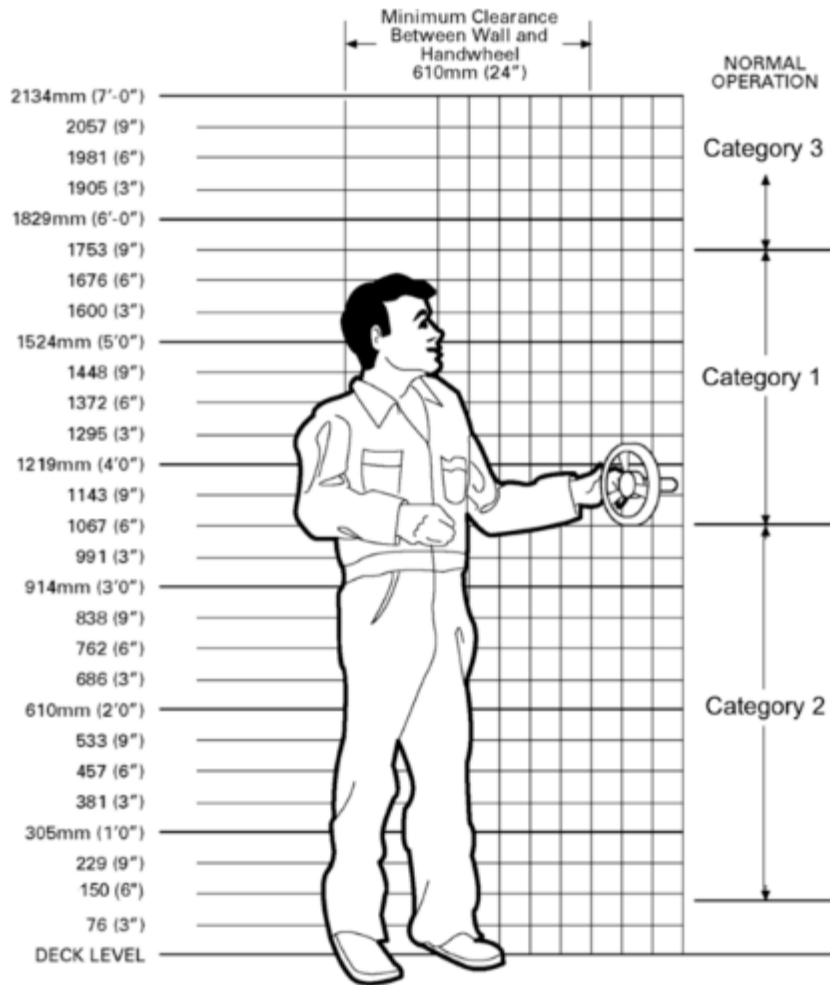

Figure 10. Mounting heights for handwheel valves with horizontal stems (adapted from ABS, 2018).

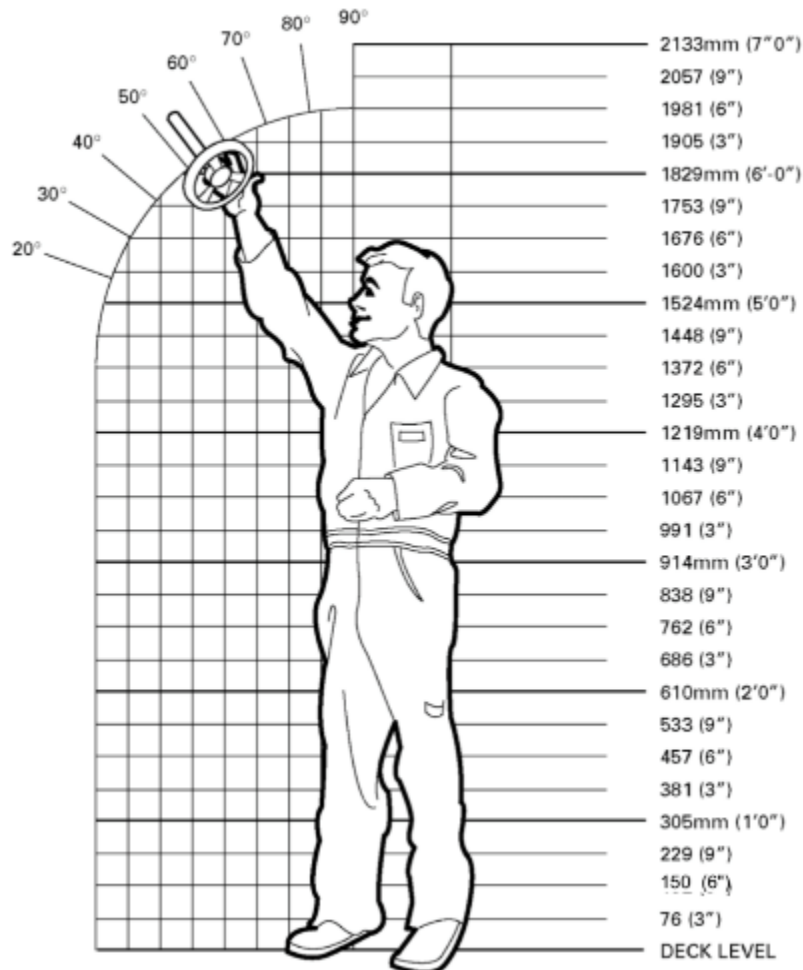

Figure 11. Mounting Heights for Handwheel Valves with Angled Stems (ABS, 2018).

Note: No category 1 valve should be located at the angle area shown in Figure 11 (20° to 90°).

No category 2 valve can be positioned above 40° as shown in Figure 11.

Lever-Operated Valves

Lever-operated valves oriented with the stem in a vertical position should be provided when the valve lever can be located between 760 mm (30 in.) and 1270 mm (50 in.) above the standing surface, as shown in figure below, "Mounting Heights for Lever-Operated Valves with Vertical Stems". (Category 1 and 2).

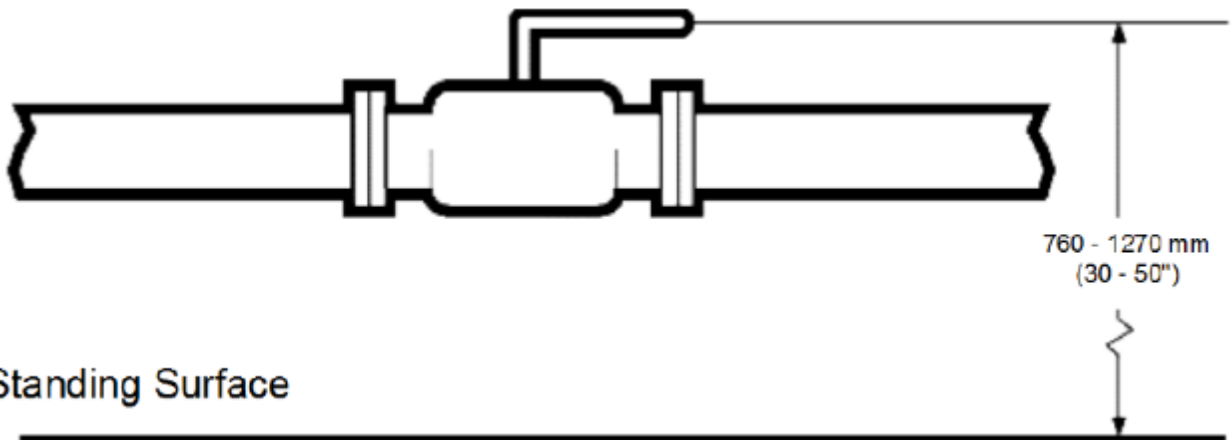

Figure 12. Mounting Heights for Lever-Operated Valves with Vertical Stems (ABS, 2018).

Lever-operated valves oriented with the stem in a horizontal position should be provided when the lever is located between 150 mm (6 in.) and 760 mm (30 in.), or more than 1270 mm (50 in.) above the standing surface, as shown in Figure below, “Mounting Heights for Lever-Operated Valves with Horizontal Stems”. The maximum height above the standing surface to the lever tip should not exceed 1900 mm (75 in.). (Category 1 and 2)

Horizontal stem valves should not be located overhead in working areas. (Category 1 and 2)

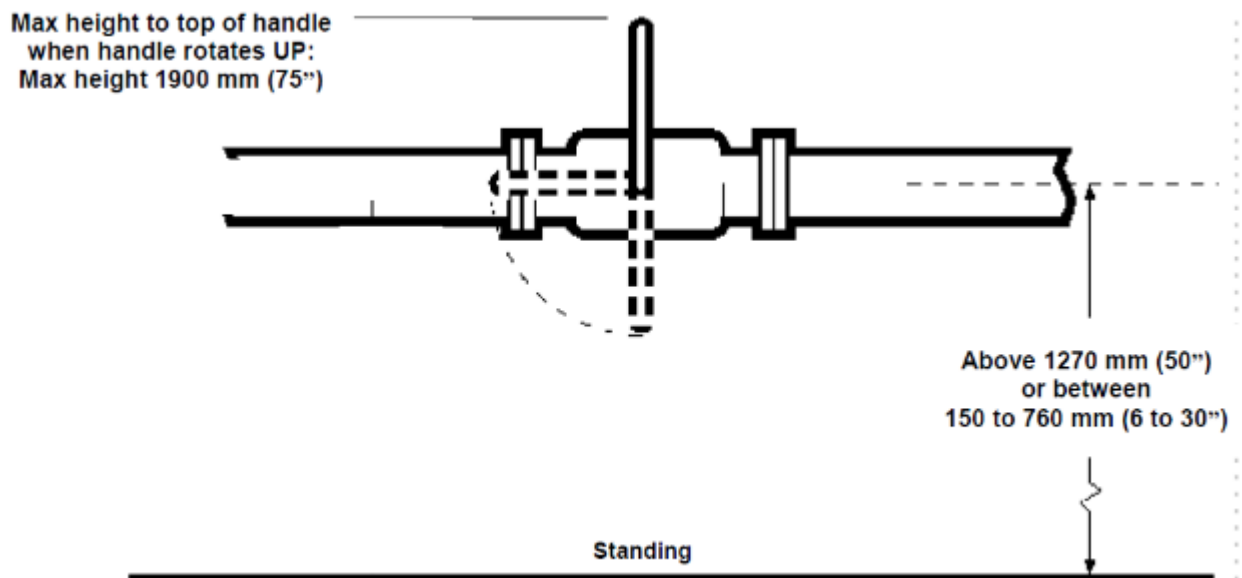

Figure 13 - Mounting Heights for Lever-Operated Valves with Horizontal Stems (ABS, 2018).

A distance of at least 300 mm adjacent to valves and equipment where bolts can be accessed from one side only so that wrenches can be used (Categories 1 and 2).

A free space of at least 760 mm should be maintained on both sides of the pipe, where access is required for operation or maintenance (Category 1 and 2).

Figure 14 shows the operator's difficulty in accessing the valve due to obstacles around it.



Figure 14. Difficulty in accessing the valve due to obstacles in its surroundings.

Figure 15 shows a category 1 valve outside the operator's range area and without resources to allow access.



Figure 15. Valve installed above the operator's range.

Prioritize vertical orientation to facilitate the use of body weight as an auxiliary force vector in the case of handwheels installed at the height of 1400 mm or more (Figure16).



Figure 16. Handwheel position, allowing the use of body weight as support.

Alternative guidance for valve positioning

- Valves accessible only on one side:

When access to a lever-operated valve is available from one side only, the valve should be assembled so that the lever moves to and from the accessible side, where the operator or maintainer will be positioned, as shown in Figure 17 (Category 1 and 2).

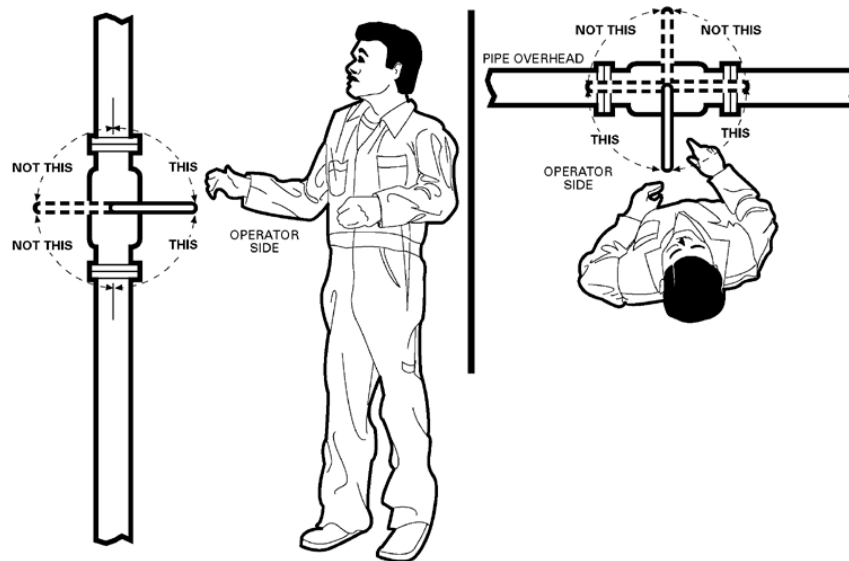

Figure 17. Direction of Travel for Valve Levers Accessible from One Side Only (ABS, 2018).

- Valves on or below the surface:

If a valve is located on or below the surface, requiring to bend or to squat for operating, the valve position in relation to the operator's or maintainer's body shall be as shown in Figure 18 (Category 3 only).

When it is necessary to locate the handwheel or lever valves below the operator's or maintainer's standing surface, the horizontal or vertical guidance valves shall be installed as shown in Figure 18 (Category 3 only).

Deck opening sizes for reach and operating levers or handwheels located below the standing surface, with parallel to surface orientation are shown in Table 2. This table also includes guidance on assembly and installation depths for valves. (Category 3 only)

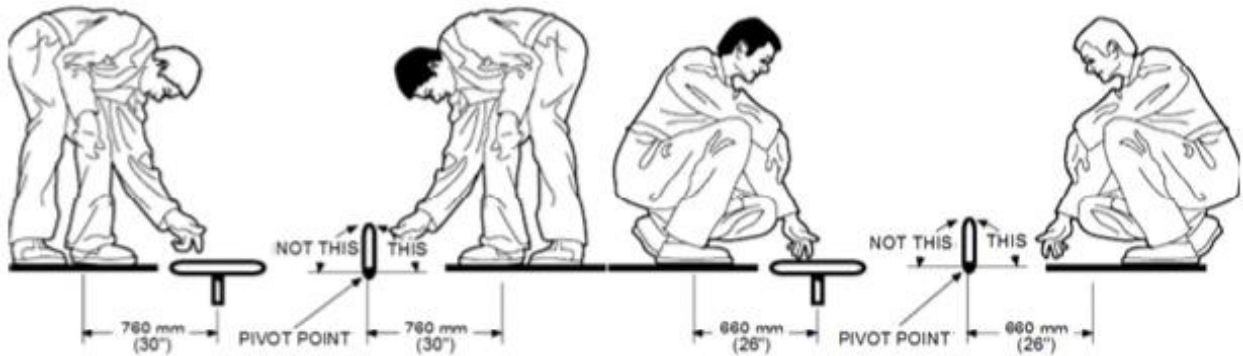

Figure 18. Physical Reach from a Stooping or Squatting Position (ABS, 2018)

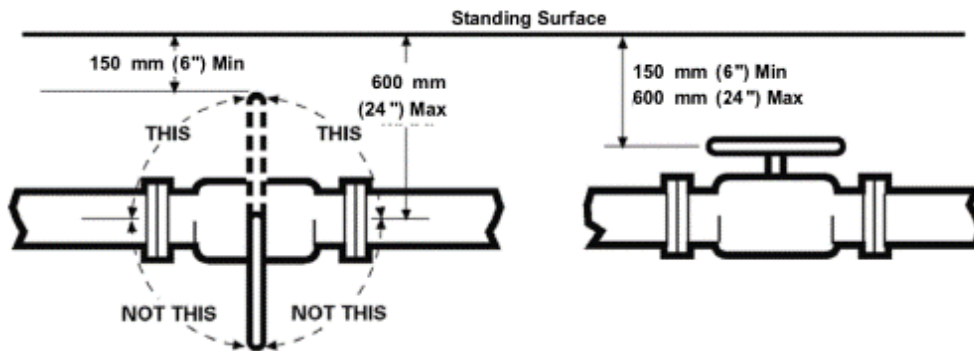

Figure 19. Mounting Position for Valve Levers and Handwheels Below Standing Surface (ABS, 2018)

Table 2. Dimensions for opening and mounting depth for levers and handwheels parallel to the surface (adapted from ABS, 2018).

Valve handle (diameter or length)	Depth below deck	Platform opening size (square or diameter)
Wheel		
130 mm (5 in.) or less	150 - 255 mm (6 - 10 in.)	180 mm (7 in.)
	255 mm (10 in.) up to 600mm	215 mm (8.5 in.)
130 mm (5 in.) or more	150 mm (6 in.) until 510 mm (20 in.)	The diameter of the handwheel plus 150 mm (6 in.) With a minimum of 360 mm (14 in.)
Lever		
Any lever length	Up to 600mm	Lever length greater than 50 mm (2 in.)

- Valves operated from a ladder

The use of a ladder for opening valves should occur only when it is not possible to build an access platform and has some restrictions as described below.

Valve levers and their action radius should not interfere with ladder-climbing place. (Categories 1, 2, and 3).

In cases where valves shall be operated from a permanent ladder, they should be limited to those that can be operated with one hand (valves with handwheels less than 155 mm (6 in.) in diameter and lever valves) (Category 1 and 2).

The ladder shall be positioned to allow the operation of a valve, as shown in Figure 20 and Figure 21 (Category 1 and 2).

These figures show the required orientation in relation to valves. The valve orientation, valve operation direction, and distances shown are applicable to both lever and handwheel-operated valves, Figure 22 provides additional guidance for placing valves in relation to ladders (Category 1 and 2).

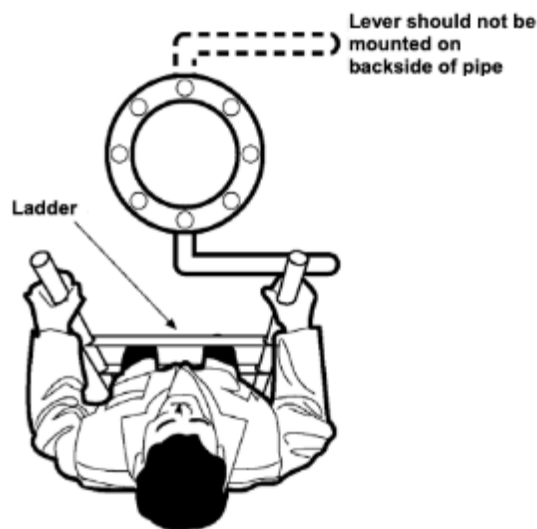

Figure 20. Orientation and range of ladder parallel to the valves (ABS, 2018).

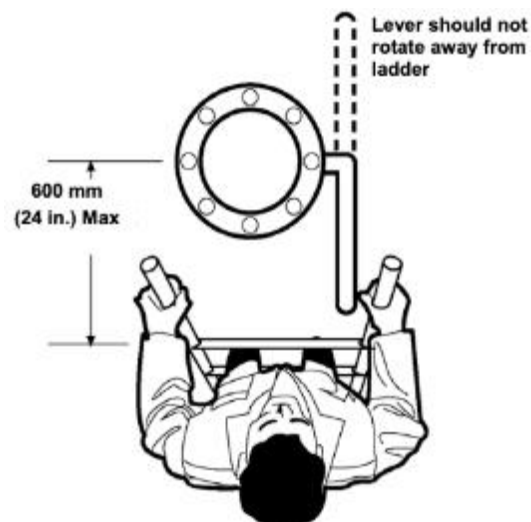

Figure 21. Orientation and Reach for Ladder Perpendicular to Valves (adapted from ABS, 2018).

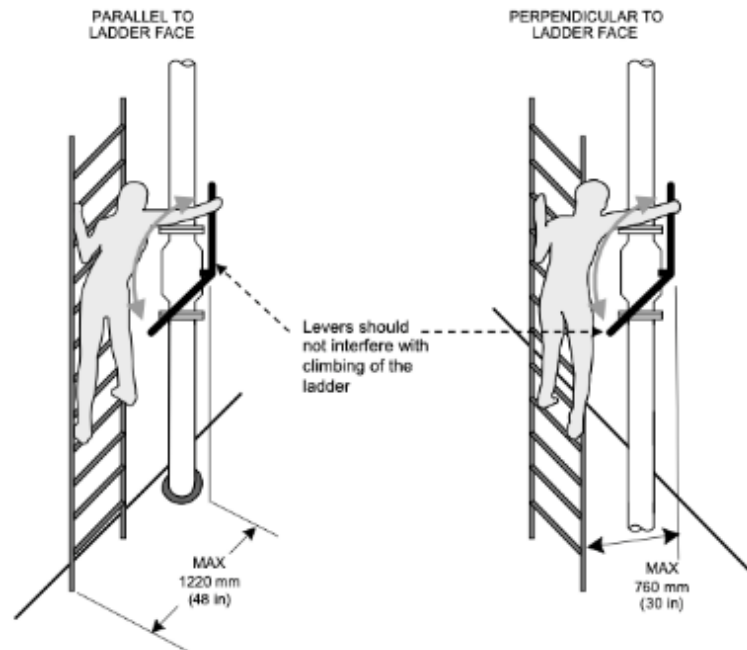

Figure 22. Operating Lever Valves from a Ladder (ABS, 2018).

Figure 23 shows 2 valves installed on the opposite side of access by ladder, making access difficult.



Figure 23. Valves installed on the opposite side of ladder, making it difficult to access.

- Valves operated from a raised platform:

Handwheels of valves operated from 1830 mm (72 in.) height platforms or more should be located within the boundaries of the platform area.

Figure 24 shows valve with access by fixed platform, but with restricted access by platform borders and by the existing structural column near the valve.



Figure 24. Valve with access by fixed platform, but with restricted access

In the case observed in Figure 25, Category 1 valves were installed near the upper floor and without access by elevated platform or ladder. For this reason, a fixed scaffolding has been installed. However, valves remain difficult to access due to the limitation caused by the upper floor.



Figure 25. Improper position of category 1 valves.

6.3 ANALYSIS TO BE PERFORMED DURING THE DETAILING DESIGN

Meeting the requirements mentioned in the item above can be verified in the 3D model and work as support for changes that may occur in the next stages of the project.

SELLER, during the detailing and/or assembly phases, shall prepare a list of valves per module, categorize them according to the rules set out in this document (categories 1, 2 and 3), and confirm appropriate access and feasibility for operation and maintenance, providing evidence through the checklist.

This list should be presented in ergonomics reports as a database table with at least the following fields filled in:

- Valve tag,
- Valve category,
- Installation height, having the floor as reference.
- Position of the handwheels,
- The actuation of the valve.

Note: This list can be consulted and extracted directly from the plant 3D model.

Another critical point related to valves is the interference between subsystems distributed among different design disciplines, which affect valve access, handling, or removal for maintenance, damaging what, at first, would be a satisfactory ergonomic condition. These interferences should be evaluated at various design review stages, especially those with the use of 3D model or virtual reality.

Portable ladders and platforms, when necessary (for Category 2 or 3 valves only), shall be represented in 3D Model to guarantee the space for positioning.

7 PIG LAUNCH AND RECEIVE SYSTEM

7.1 GENERAL CONSIDERATIONS

The objectives of the PIG passage are the removal of accumulated waste from the product flow and inspection in the production/ piping lines. For cleaning and inspection services, non-instrumented and instrumented PIG are used. There are typical usage routines, as follows:

- Manual insertion and removal of the receiving basket,
- Alignment (or realignment) of PIG receivers and launchers,
- Depressurization of the chamber,
- Drainage of the chamber by opening the manual actuation valve,
- PIG insertion,
- Closing of the chamber closure,
- Checking the PIG launching,
- Checking the PIG arrival.

7.2 REQUIREMENTS

Based on use routines, conditioning and design variables, and rules/regulations applicable to this system, technical and ergonomic recommendations were generated, as follows:

Table 3 Requirements and purpose of the PIG launching and receiving system.

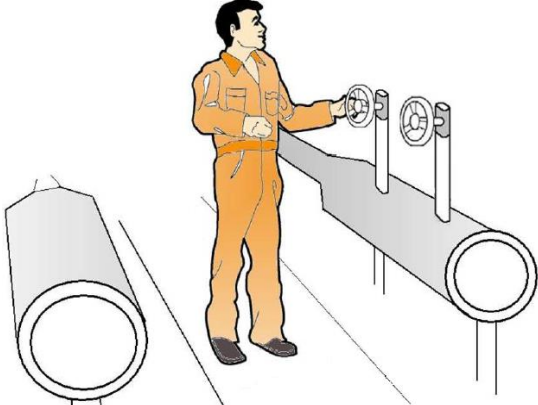
REQUIREMENTS	PURPOSE
1. The area in front of the chamber closure shall be free of pipes and / or valve handwheels.	To facilitate the operator's access due to the need for the use of equipment that requires space, such as stems and receiving baskets.
2. The receiving basket should not provide resistance to its insertion and removal. Its structure shall be well adjusted to the chamber dimensions and made of resistant material to increase durability.	The basket should be of a light alloy, such as aluminum.
3. The access area to handwheels shall be free of obstructions, and the floor on such an area shall be flat.	To facilitate operation, allowing proper posture to the operator.  Figure 26. Proper operator posture
4. Definition of launchers/receivers handwheels height of alignment valves and drain valves shall be permanently accessible on the same floor of the deck or elevated surface. If these two alternatives are not feasible, permanent access by stairs is acceptable.	Provide safe and efficient access to the operator.
5. The maximum height of the handwheels shall be according to item 6 (Valves), and its figures indicate the most appropriate distances for positioning handwheel valves.	Provide safe and efficient access to the operator.
6. If complete and isometric acting torques of alignment valves are larger than 15 N.m, reducing gearboxes is recommended.	Enable safe handling and physical effort reduction.



TECHNICAL SPECIFICATION	Nº I-ET-3010.2Q-1400-196-P4X-001	REV A
MARLIM LESTE E SUL		sheet 32 of 57
TITLE: ERGONOMICS REQUIREMENTS FOR TOPSIDE		INTERNAL
		ESUP

7. By-pass PSV valve triggering should be at the same level and close to the PIG launch and receive chambers.	Eliminate operator displacement by stairs and reduce operation time.
8. The camera manometer should be placed in the operator's sight when he handles the PSV by-pass valve.	To avoid unnecessary displacement between stations and PSV zone.
9. Use of a manometer that allows for the reading pressures below 2.0kgf/cm2.	Make reading easier and consequently increase operation safety.
10. Provide devices to assist PIG placement into the launching chamber, such as a tray that directs the foam PIG (similar to those used in instrumented PIG launchers).	Improve operation safety, reduce operator physical effort, and avoid damage to the PIG.
11. Cover locking device shall allow for a safe closing with little effort.	Improve operation safety and reduce operator physical effort.
12. Access to the grease pin of stations shall be as free from obstructions as possible. Pin height should be 1500 mm.	Allow maintenance operator to fit the pump on the pin and perform the task.
13. Access to stations' flanges and eyebolts shall be free of obstructions and have clear surroundings. The maximum height of these devices should not exceed 1500 mm.	Allow maintenance operator to perform a complete cleaning and lubrication of these devices.
14. The surroundings of valves, handwheels, and stations shall have enough space for valve operation (area of at least 0.50m ²).	Enable proper posture for the operator. The maintenance operator may make positions that allow greater torque with less physical effort and alternating rest positions with positions of a low, medium, and intense effort.
15. In accordance with the requirements for the PIG launcher and receiver design (I-ET-3010.00-1200-295-P4X-001), a safety device shall be installed to prevent the chamber from opening if there is still pressure inside it. The cap should have a single vent.	Improve operation safety and avoid accidents during equipment operation.
16. Foresee PIG receiving and launching transmission monitoring through control room systems, in addition to the local indicator. OBS: According to operators, flag and magnetic sensors are unreliable in practice.	Allow operators to monitor the evolution of maneuver.

<p>17. Tag making (identifier codes for equipment) should consider the degrading effects of an offshore environment and exposed environments, such as a platform process plant, according to Chapter 11 of this document (I-ET-3010.2Q-1400-196-P4X-001).</p>	<p>Durable tags maintain the integrity of equipment identification to avoid human error during maneuvers.</p>
---	---

In this way, problems can be anticipated in terms of operation safety, improper efforts and postures, access and movement difficulties, difficulty in execution (or operation / functionality), risks of accidents, need to increase the number of operators involved in the task.

7.3 INTERLOCK SYSTEM

If an interlocking system is installed to ensure the correct sequence in the PIG launching and receiving routine, it will be defined by BUYER during detailing project.

Key panel is to be installed at CCR and the unit that controls sequencing shall be installed in a location that prioritizes the minimum vertical operator displacement (by stairs), considering all activity stages that use the interlock system.

- Cover articulations shall be made of noble material, resistant to corrosion, with the purpose of not compromising the operation of the interlocking system.
- The keys shall be designed with protection so that, in case of fall, they shall not pass through the gaps of the grated floor

8 STAIRS AND ACCESS WAYS

8.1 GENERAL CONSIDERATIONS

The accesses listed in this document are the means by which operators enter or leave areas, locations, modules, and equipment where the activities of operation, inspection, or maintenance are carried out, being the operators with free hands or carrying tools, equipment, samples, etc. A relevant aspect is that the “access ways” are also the means of escape in an emergency or even removal of an injured person for medical healthcare.

Offshore facilities carry a strong constraint in terms of spaces. Consequently, the vertical integration of production modules has been adopted, requiring the installation of stairs to access systems and equipment.

The supply of modules by different manufacturers generates heterogeneous conditions in terms of design. For example, there are different rails for handling equipment and materials, different dimensions and heights of stairs, different pathways dimensions and configurations. This context can hinder displacements for performing routine operations or for escaping in case of emergencies. Another recurring problem is the lack of access to places where maintenance should be done, which

causes the need to install scaffolding and the use of alternative means of access. In all situations pointed out, access absence or precarity intensifies operators' efforts and displacements.

For this reason, it is essential that project participants, manufacturers, and module suppliers, integrate technical specifications and ergonomic recommendations into their products, providing access and leveled pathways with platforms, ramps, or a minimum number of steps, taking into account the actions necessary to work performance.

8.2 ACCESS

Access is the means by which operators act in systems and equipment either for operation, inspection, or maintenance and for displacements in the operational area. The general requirements for the design of accesses are described in Table 4 presented below, resulting from previous reference situations.

Table 4. Requirements and purpose for providing access

REQUIREMENTS	PURPOSE
<p>1. Leveled pathways (with platforms, ramps, or with the minimum number of stair steps) shall be provided to interconnect the different elevations of the modules, for example:</p> <ul style="list-style-type: none"> - Between the electrical module and the generators power panels room, - Between all places with power generation equipment, - Between the modules of flare system, exportation gas compression and CO2 removal, and - Between all adjacent modules. 	<p>To standardize different module levels, avoiding excessive displacements by stairs, especially when types of equipment are located in other places.</p>  <p>Figure 27. Interconnected modules</p>
<p>2. Platforms shall be provided to connect the devices involved in the same task.</p>	<p>To avoid excessive displacements of operators.</p>
<p>3. Install pad eyes or supporting points for removable ladders where possible.</p>	<p>Facilitate access to equipment and systems maintenance, minimizing the risk of falls caused by platform movements.</p>
<p>4. Stairs and platforms shall be provided to allow maintenance of overhead cranes and elevated equipment.</p>	<p>To minimize scaffolding installation.</p>
<p>5. Reset buttons of emergency valves shall be positioned in an accessible place (considering the equipment's position).</p>	<p>To avoid displacement of operators by stairs or over pipes shutdown periods.</p>
<p>6. Install handrails and guardrails of metallic material near the laydown area.</p>	<p>Reduce damage due to impacts of the cargo handling using the cranes</p>

<p>7. Access to the crane cabin shall occur through vertical type stairs according to the rules listed in this document.</p>	<p>Facilitate access of the crane operator.</p>
<p>8. A second access to the crane cabin shall be provided at the top of the adjacent modules.</p>	<p>Reduce operator displacement through multiple stairs since he is also responsible for operating other material handling devices such as carts and cranes, in addition to the crane.</p>  <p>Figure 28. Cabin and crane with alternate access.</p>
<p>9. Specify ladders' stages to access control cabin of cranes with appropriate dimensions, specifying nonslip material.</p>	<p>To avoid falls during access to the control cabin.</p>
<p>10. Provide access from <i>Topside</i> to Accommodation Module at Starboard and Port. This access shall reach the Accommodation Module at the same level as the pipe rack.</p>	<p>To facilitate emergency access to protected areas of the unit.</p>
<p>11. Provide access between modules in the <i>piperrack</i> to facilitate the movement of operators for inspection control.</p>	<p>Facilitate operators' access to critical modules of the unit.</p>

8.3 STAIRS, LADDERS, AND RAMPS

Stairs, vertical ladders, and ramps are structures used for changes of elevations greater than 500 mm or used as passages over pipes or other equipment.

Skids and/or equipment shall have access (such as steps) where the operator needs to access instruments or valves or perform maintenance.

The design shall consider the characteristics of an FPSO to fulfill their needs, increasing safety and minimizing the risk of accidents.

The detailing of these structures should consider the objective, frequency of use, and angle of inclination.

8.3.1 STAIRS

The stairs shall be used for moving between levels when vertical elevation is greater than 500 mm and when there is space available for inclination between 38° and 45° (Figure 29).

Table 5 presents the main recommendations for the design of stairs and their respective dimensions. When designing these means of displacement, it is important to consider the need to carry equipment or parts, as occurs in the case of maintenance team operators.

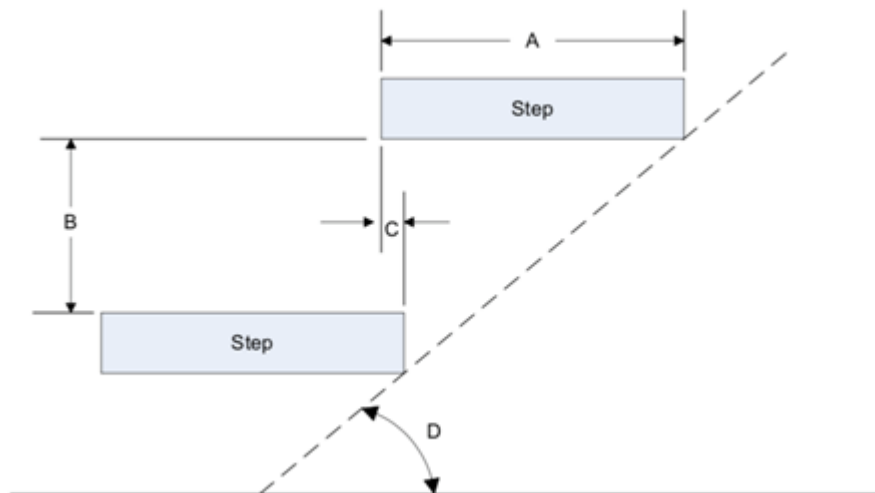

Figure 29. Stair Riser and Step Design (ABS, 2018)

Table 5. Stair Riser and Step Design (adapted from ABS, 2018 and ASTM F-1166)

Dimensions		Requirements
A	Step Depth	230mm to 280mm
B	Vertical distance between steps	178mm to 230mm
C	Step overhang distance	22mm to 25mm
D	Steps angle of inclination	38° to 45°

International Standards (ABS, 2018) recommend that stairways to main pathways, where evacuation is required, should be at least 1,200 mm wide. Other ladders shall be at least 1,000 mm wide. Stairs that are rarely used can be 710 mm wide. These measures provide minimum safety conditions for users, especially on frequently used stairs and emergency situations.

Other requirements for the design of stairs are:

- Consider vertical free space of at least 2,100 mm between all floors serviced by stairs and free of any obstruction located above them.
- Provide obstacle-free spaces at the bottom and top of the ladder with the same stair width and a minimum width of 915 mm.
- Ensure at least 1525 mm width for intermediary levels when the steps change direction.

Other parameters for the design of stairs are indicated in Table presented below.

Table 6. Stairs requirements and purpose.

REQUIREMENTS	PURPOSE
1. Stairs to access utility room (or engine room) should receive special attention during detailing design. These locations have long stairs as escape routes, which connect the main deck to the bottom of the vessel.	Decrease the criticality since they are the stairs with the highest frequency, length, and need for displacements while carrying materials
2. Use standardization for all stairways, keeping the same width, height, and depth of the stairs or any ladder on the platform.	Prevent operators from being injured, especially in emergency situations and while carrying materials. 
3. Provide edge with slip-resistant and bright colored rubber ribbon or similar material, visually highlighting it over the remaining steps.	Avoid slips and falls of operators.
4. Provide a landing on each deck where the ladder is the mean of reaching. The intermediary level shall have the same dimensions as the base levels.	Provide safe and comfortable conditions for using stairs.
5. In places where it is necessary to remove any equipment for maintenance, provide a removable ladder with fixation at the top and bottom. Stairs that serve as a means of escape in emergency situations shall be permanently installed.	Provide safe conditions on the use of stairs.

8.3.2 VERTICAL LADDERS

Vertical ladders are used in cases where there is limited space, and it is not necessary the displacement while carrying loads. This type of ladder shall be avoided as the main escape route, and during usual accesses for maintenance and operation.

Only ladders for occasional use (frequency less than once every 6 months) and which do not constitute an escape route may be higher than 5,0m. Ladders such as flare access and hull cargo tanks, may be longer than 5,0m as long as they have fall arresters.

To ensure safety conditions in operator displacement and prevention of falls, the main parameters for the design of vertical ladders are:

- Consider the maximum distance of 965 mm from the centerline of the ladder to the object reached by a person when using the ladder. The inclination angle shall be between 75° and 90° from the floor for a vertical ladder.
- Install stringers on both sides of the ladder along the entire length, constructed with pipes of the nominal diameter of 40 mm. Stringers shall be between 225 mm and 450 mm apart. Stringers should extend at least 1,350 mm above the intermediary levels or platforms (see Figure 31).
- Install intermediary platforms where the height of the vertical ladder exceeds 6000 mm (ASTM F-1166).
- Maintain a minimum horizontal distance of 180 mm (preferably 205 mm) behind the stairs and 100 mm behind the steps.
- Provide an open area of at least 760 mm wide and length in front of the vertical ladder.
- Limit the distance from the edge of the ladder stringer to the side platform to be accessed by 300 mm, with a preferred distance of 150 mm. There should be a step on the vertical ladder at the same height as the surface of the intermediary platform (see Figure 31).
- Provide a minimum vertical clearance of 2,100 mm above the top step and a horizontal distance of 380 mm between the centerline of the ladder and the nearest obstruction on both sides.
- Use protective cages if the ladder has a height of 3500 mm or more. The cages shall be installed 2000 mm in height from the floor. If it is in an escape route, it shall be 2100 mm in height,
- Safety cage shall be extended 1100 mm above the higher level.
- For all vertical ladders, with height equal or greater than 5,0m, a guided fall arrester or a retractable fall arrester shall be installed. For guided type fall arrester, a vertical cable shall be installed. For retractable fall arrester an anchorage is required.

Provide horizontal separation between two vertical ladders, stringer to stringer, using an intermediary platform. The separation should not be greater than 450 mm (see Figure 31).

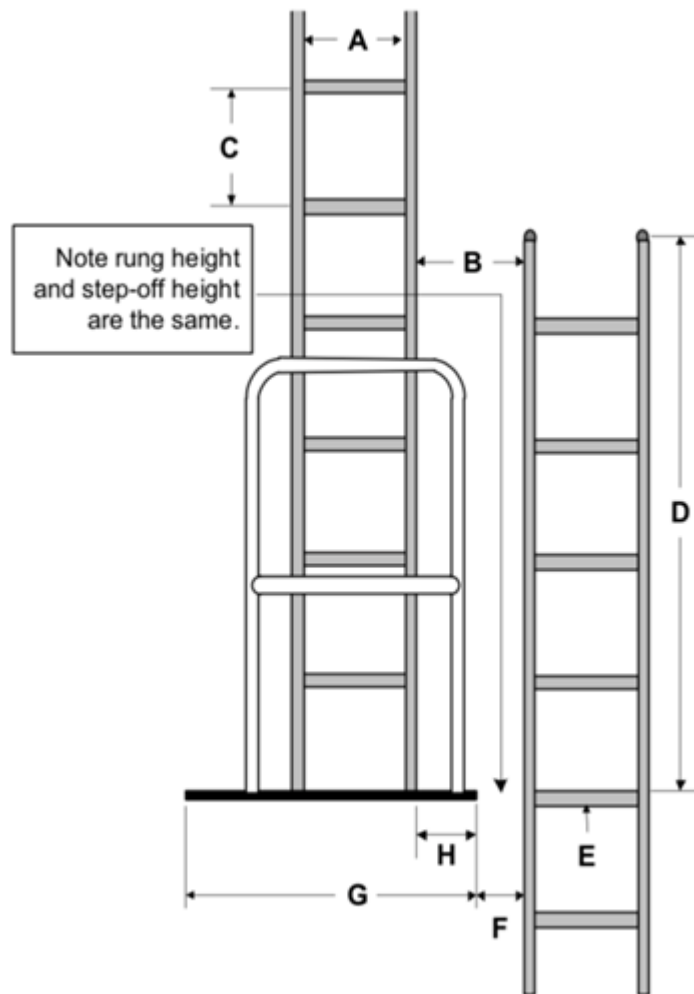

Figure 31. Vertical ladders (ABS, 2018).

Table 7. Requirements for staggered vertical ladder (ABS, 2018)

Dimensions		Requirements
A	Stringers separation	400 to 450mm
B	Horizontal separation between two vertical ladders, stringer to stringer	≥225mm ≤450mm
C	Distance between ladder rungs (evenly spaced throughout the full run of the ladder)	≥270mm ≤300mm
D	Stringer height above landing intermediary platform	≥1350mm
E	Rung Design – (Preferably round. Alternatively, a square bar can be used. Where a square bar is fitted, orientation shall be edge up)	Square bar: 25mm x 25mm Round bar: 25mm diameter
F	Horizontal separation between ladder and platform	≥150mm ≤300mm
G	Landing or intermediary platform width	≥925mm
H	Ladder or platform edge	≥75mm ≤150mm

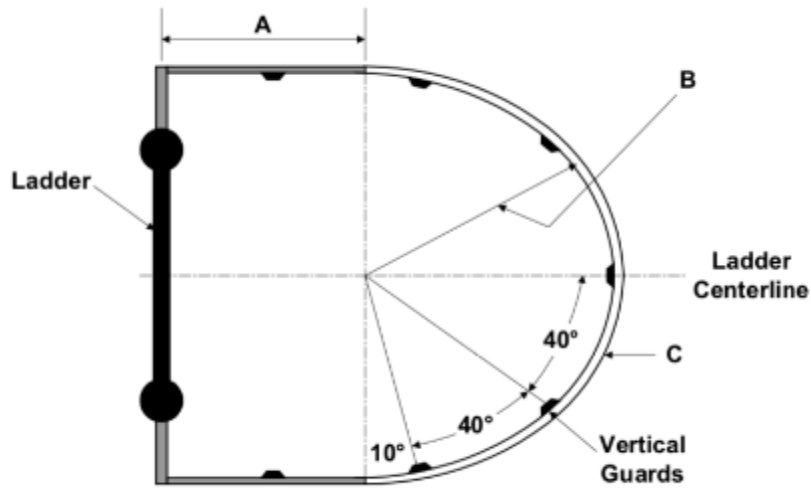

Figure 32. Arrangement for safety cage for a climber or ladder-type vertical (ABS, 2018)

Table 8. Requirements for the arrangement of the climber's safety cage or vertical ladder (ABS, 2018)

Dimensions		Requirements
A	Distance from centerline of ladder rung to the point of radius of safety cage horizontal guards	350 mm
B	Horizontal guard radius	Horizontal guard as the bottom of the cage: 425 mm All other horizontal guards: 350 mm
C	Vertical separation of horizontal guard placement	≤ 1200 mm

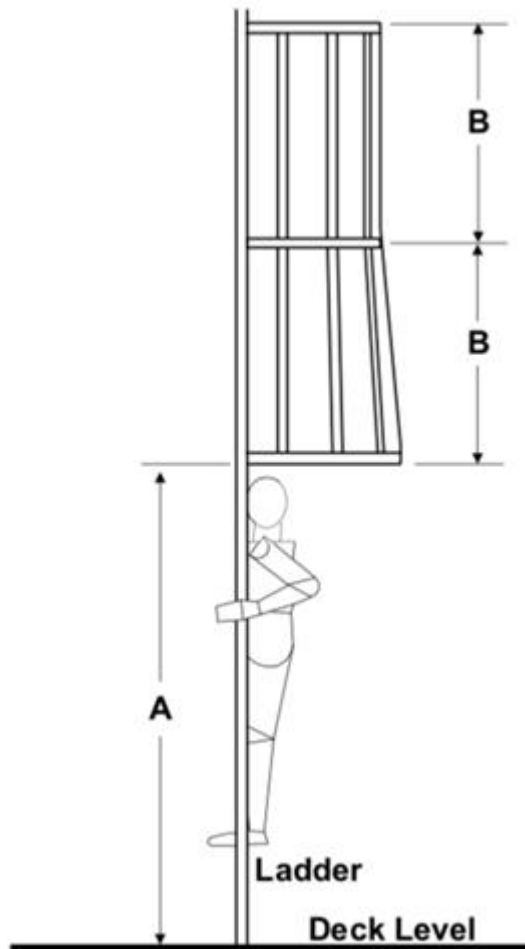

Figure 33. Climber safety cage or vertical ladder - side view (ABS, 2018)

Table 9. Requirements for safety cage of climber or vertical ladder (adapted from ABS, 2018) – side view

Dimensions		Requirements
A	Distance above the upright surface	2000 mm 2100 mm (the escape route)
B	Vertical separation of horizontal protection placement	≥1140mm ≤1220mm

Other recommendations for the design of vertical ladders are shown in Table 10, presented as follows.

Table 10. Requirements and purpose for vertical ladders

REQUIREMENTS	PURPOSE
1. Vertical ladder should be attached to a permanent structure. When a task requires both hands, the vertical ladder is not appropriate, and the workplace should have a platform with a flat, stable surface.	Ensure safe conditions for operators to move.
2. Design landings on a ladder that reach different subsystems.	Reduce the number of ladders, avoiding excessive displacement of operators.
3. Prevent the installation of a ladder next to the equipment, both at the base and at the top of the ladder.	Free up the space required for any intervention in the equipment and allow the use of the ladder without obstruction.
4. Maintain a pattern for the ladder, with uniform spacing between the steps along its entire length, including the distance from the last step to the ground. Where multiple steps are provided to cover the vertical length, the same distance from the steps should be used for each of the ladders.	Ensure safe comfort and conditions for operator swaying, especially in emergency situations and cargo handling.
5. The steps shall have nonslip material finishing.	Ensure safe conditions for operators in the use of stairs, avoiding slips and falls.
6. The vertical ladder shall be fixed to the base floor with a free area at the front and without any unevenness.	Ensure safe conditions for operators in the use of ladders.
7. Intermediary platforms shall be provided with handrails and skirting boards on all sides that are not used to reach the ladder.	Ensure safe conditions for operators in the use of ladders.
8. The handrail shall be installed on the exposed side of any surface of a platform higher than an adjacent platform, from which a person may fall.	Ensure safe conditions of use for operators on platform displacements.
9. Work platforms shall be large enough to perform a task and accommodate all necessary spare parts or equipment.	Provide conditions for activities to be developed in the appropriate and safe space.
10. The platforms used to reach a vertical ladder should provide a flat and clear area in front of the ladder.	Clear the necessary space for the safe use of the vertical ladder.



TECHNICAL SPECIFICATION	Nº I-ET-3010.2Q-1400-196-P4X-001	REV A
MARLIM LESTE E SUL		sheet 43 of 57
TITLE: ERGONOMICS REQUIREMENTS FOR TOPSIDE		INTERNAL
		ESUP

11. Vertical ladders used to access a deck, a work platform, roof installations, or the top of a tank, shall have the last step leveled to the surface.	Ensure safe conditions for the displacement of operators, avoiding falls.
12. Installation height of protective cage shall be appropriate, especially on high frequently used ladders, such as the one used for accessing the crane control cabin. Evaluate the use of safety line, according to NR-35.	Avoid the discomfort of operators in vertical ladders, especially when handling materials displacement is necessary.

8.3.3 ADDITIONAL PROTECTION FROM SECONDARY FALL POINTS

Vertical ladders should not be located in within 1.83m (6 ft) of other nearby potential fall points (including deck edge, cargo holds and lower decks) without additional fall protection such as guardrails.

Additional fall protection should be provided for the ladder climber in these situations:

If vertical ladder (of any height) is located within 1.83m (6 ft) of another nearby potential (secondary) fall point (for example overboard or to a lower deck or landing), and

If the potential fall height is greater than 4.60 m (15 ft). The potential fall distance is the height of the ladder plus the height of the secondary fall, and

If no active fall protection is fitted to the ladder (a safety cage is not considered to provide active protection), then

Additional fall protection to the ladder climber shall be provided, regardless of whether a climber safety cage is fitted to the ladder

Table 11. Requirements for vertical ladders without safety cages or climber safety rails/cables

Dimension		Requirements
A	Horizontal distance between ladder and rails	≤1830 mm (72 in)
B	Vertical distance from top of rail to top of ladder	≤ 760 mm (30 in)

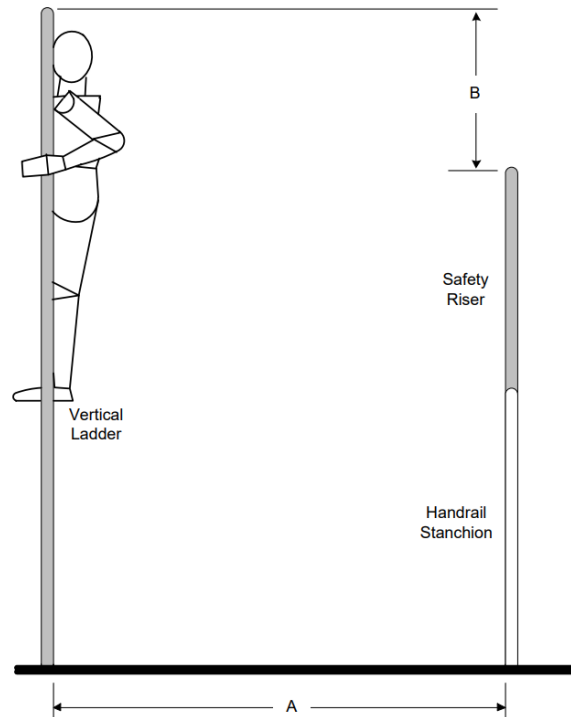

Figure 34. Side view of guardrail requirements for vertical ladders without safety cages or climber safety rails/cables (ABS 2018).

Table 12. Guardrail requirements for vertical ladders with safety cages and without climber safety rails/cables

Dimension	Requirement
Height of vertical guardrail	The height shall extend to within 760 mm (30 in.) of the lower edge of the safety cage
Width of vertical guardrail	Protection shall be provided for a minimum of 1220 mm (48 in.) on each side of the centerline of the ladder
Distance between guardrail extension courses or tiers	A maximum of 460 mm (18 in.) shall be provided between guardrails courses or tiers of the guardrail extension. The measurement shall be taken from the course or tier outside diameter to outside diameter.
Horizontal distance between ladder and rails	1830 mm (72 in.)

Table 13. Guardrail requirements for vertical ladders with safety cages and without climber safety rails/cables

Dimension		Requirements
A	Vertical distance between safety cage and rail	≤ 760mm (30 in.)
B	Vertical distance between safety cage and platform	2130 mm (84 in.)

Note: Assumes that the potential fall distance is greater than 4575 mm (15 ft) where there's a safety cage, but no climber safety rail or cable is present.

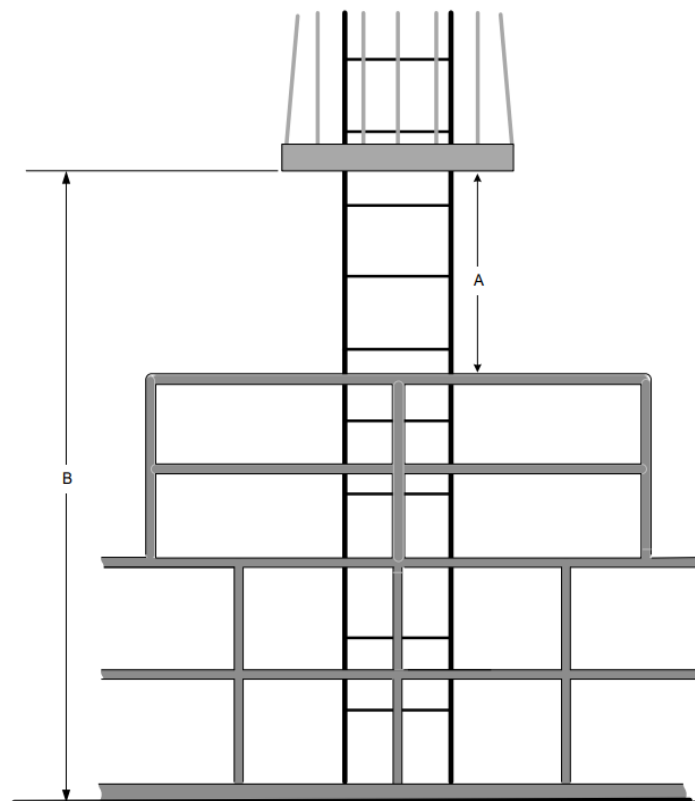
Figure 35. Front view of guardrail requirements for vertical ladders with safety cages and without climber safety rails/ cables (ABS 2018)

8.3.4 HANDRAIL AND GUARDRAILS

In stair design, handrails shall be provided to ensure the workers' safety during their displacement. They prevent falls and assist in maintaining balance while climbing or descending the ladder. Handrails shall be installed on the side of a bulkhead.

An important item to consider is the distance between handrails and bulkheads, which should be sufficient for fitting a hand. Sudden interruptions, which usually occur due to obstacles and usually generate impacts for operators, should be avoided. Another problem is the lack of standardization in handrail profiles, such as the use of square and round profiles installed on the same platform.

The guardrails should be manufactured, avoiding discontinuities, sharp edges on the surface, or any other factor that may cause damage to the health and physical integrity of users. If discontinuity exists, it shall be between 75 and 120 mm.

Table Table 14. Selecting the type of handrail and guardrails shows some parameters for selecting the type of handrail and/or guardrails:

Table 14. Selecting the type of handrail and guardrails

Application	HANDRAIL AND/OR GUARDRAIL
Larger than 1200 mm with a bulkhead on both sides	Handrail on both sides
Less than 1200 mm with bulkhead on both sides	Handrail on one side, preferably on the right side, descending.
Larger than 1200 mm, one side exposed, another side with bulkhead.	Guardrail on exposed side, handrail on bulkhead side.
Less than 1120 mm, one side exposed, the other side with bulks	Guardrail on the exposed side
All widths, both exposed	Guardrail on both sides

Requirements for handrail and guardrail design are pointed out below:

- Provide handrail or guardrail on a stair with three or more steps (about 500 mm).
- Preferably use circular section pipes with 40 mm diameter for the construction of handrails and guardrails and maintain, if possible, this measure on any platform.
- Observe a minimum clearance of 75 mm between the handrail and the bulkhead or other obstruction.
- Provide height of 1,100 mm (center line) for handrail or guardrail of floors and platforms.

Other requirements for the installation of handrail and guardrail are presented in Table 15

Table 15. Requirements for handrail and guardrail

REQUIREMENTS	PURPOSE
The handrail shall have at least two intermediary bars, depending on the user's exposure to falling. Shall be installed on the exposed side (not closed).	Ensure safety while going up and down the ladder, preventing operators from falling.
Installation of squared profiles should be avoided once they do not allow an ergonomic hold on to handrails/guardrails. As a consequence, usage becomes uncomfortable because of its edges.	Ensure safety and comfort for operators.

8.3.5 RAMPS

Ramps are recommended for level changes where the inclination angle with the floor is not greater than 15°. They should be employed when the operator moves bulky cargo through carts and wheeled devices.

Table 3 shows the recommended standards, such as ASTM (2013) and ABS (2018):

Table 16. Situations indicated for ramp usage

RAMP USAGE	RECOMMENDED ANGLE
Pedestrian traffic not handling materials	7° (recommended) – 15° (maximum)
Pedestrian traffic with material handling	4° (recommended) – 7° (maximum)
Manual devices with wheels	4° (maximum)
Motor vehicles	7° (maximum)

The main requirements for the installation of ramps are:

- Ramps that are part of the main evacuation route shall be 1200 mm wide or larger. Ramps that belong to secondary routes shall be 1,000 mm or larger.
- Provide intermediary levels of approximately 1600mm in places where ramps change direction.
- Provide landings with the same ramp width and a minimum length of 1525 mm at the beginning and end of the ramp.

Other requirements for the installation of ramps are presented in Table 17 below:

Table 17. Requirements and purpose ramps

REQUIREMENTS	PURPOSE
1. Provide handrails along the entire ramp.	Ensure safe conditions for operators in the use of ramps.
2. Ramps shall be provided with a nonslip surface.	Ensure safe conditions for operators in the use of ramps, avoiding slips and falls.
3. Provide ramps over pipes and structures located on escape routes.	Ensure safe conditions for operators in platform displacements, particularly in emergency situations.
4. Provide means of access between decks and adjacent modules.	Allow quick and safe access by the operator, minimizing the length of displacements.

9 INSTRUMENTATION

As a classification of the flow measurement points, we have:

- Fiscal: measurement to account for the daily volume produced, where government participation affects.
- Allocation: measurement for production apportionment per well and field for the division of governmental participation among the municipalities, in addition to defining the production potential of each well.
- Custody Transfer: measurement of the volume transferred between units, with ownership change.
- Operational: measurement for monitoring and process control.

The equipment responsible for the Flow Measurement System (FMS) requires constant intervention, both for legal and regulatory compliance issues, as well as for equipment maintenance and due to changes in the operational characteristics of the unit.

As a consequence, FMS equipment shall be installed to facilitate intervention during their operation and maintenance, increasing safety and avoiding ergonomic problems related to the operator actions on handwheels or valve levers, such as:

- Inaccessibility,
- Inadequate posture,
- Restrictions to use / handle,
- Difficulty in handling / opening valve.

It is recommended that the following aspects be considered in FMS design:

TECHNICAL SPECIFICATION	Nº I-ET-3010.2Q-1400-196-P4X-001	REV A
MARLIM LESTE E SUL		sheet 49 of 57
TITLE: ERGONOMICS REQUIREMENTS FOR TOPSIDE		INTERNAL
		ESUP

- All meters shall be accessible to the operator, near the floor or with access platforms, according to the requirements of the category 1 valves, as well as their respective sample collection panels.
- For flowmeters (and their respective straight lengths) classified as fiscal, allocation, and custody transfer, facilities should be provided for cargo handling, to carry out dimensional inspections periodically, landing counters for maintenance, or even moving the flowmeters in the unit.
For treated oil flowmeter of well service, consider that it will be calibrated in the offloading skid, so that it shall be expected to move it in the unit, as well as the diesel flowmeter of well service and export/import gas flowmeters, that they will be calibrated in an onshore laboratory.
- If access to the FMS equipment is undertaken by vertical ladders, provide a cargo handling device for handling in case of maintenance or calibration.
- For oil flowmeters of the test separator, consider that they will be calibrated in the fiscal oil skid so that it shall be expected to move them in the unit.
- All secondary instruments related to metering points (pressure transmitters, differential pressure, temperature, in-line analyzers, and automatic samplers) shall have access and sufficient space to remove calibration equipment.
- Special attention to thermowells, in-line analyzers, and automatic samplers, as they have an insertion probe.
- For senior office fittings (SOF), a space to withdraw the orifice plate and insertion maneuvers shall be considered. Space is required at the top of the SOF to remove the plate and also around the SOF to operate crank and valves for opening valves.
- Sufficient space shall be considered for transducers removal from the ultrasonic flare meters, as well as providing space for dry calibration, taking into account the length of the cable.
- For Coriolis type meters, special attention should be given to the meter's size not to compromise its installation.
- Consider space near compact provers for temporary installation of seraphim tank for prover calibration.
- During detailed design, a list of instruments should be prepared per module, categorized (cat. 1, 2), and confirmed the appropriate access and feasibility for operation and maintenance, providing evidence through the 3D MODEL.
 - Category 1 instruments should be considered those with a display, whether analog or digital,
 - Instruments without a display should be considered as Category 2 instruments,
 - Instrument block valves should be considered as Category 2,
 - Any valve/instrument outside the Category 1 or 2 limits shall be listed and submitted to BUYER for analysis/approval.

All ergonomic requirements described in item 6.7 of I-ET-3010.00-1200-800-P4X-013 (GENERAL CRITERIA FOR INSTRUMENTATION PROJECTS) shall be met.

10 PRESSURE VESSEL

Every pressure vessel shall be installed so that all drains, breather, manways, and level, pressure, inspection windows and temperature gauges, when available, are easily accessible.



TECHNICAL SPECIFICATION	Nº	I-ET-3010.2Q-1400-196-P4X-001	REV A
MARLIM LESTE E SUL		sheet	50 of 57
TITLE:		INTERNAL	
ERGONOMICS REQUIREMENTS FOR TOPSIDE		ESUP	

Access of removable access for manways shall be modeled in 3D model to assure viability of assembly. In case of operations that require more than one operator, ventilation equipment and/or rescue team, the size of the scaffolding system modeled in 3D model shall be compatible with the activity.

All pressure vessel manways and skirt's access openings shall comply with I-ET-3010.00-1200-540-P4X-001 - REQUIREMENTS FOR PRESSURE VESSELS DESIGN AND FABRICATION.

11 SIGNALING / VISUAL COMMUNICATION

Correct and legible signaling of valves and equipment is essential for identifying operating points in the production area. The material for tagging equipment should be checked, especially due to the wear and tear to which they are exposed, to ensure that the information contained therein is preserved.

The manufacture of TAGs (equipment identifier codes) should consider the degrading effects of an offshore environment, especially in open environments, such as the process plant of a platform. Durable TAGs will maintain the integrity of equipment identification, avoiding errors for operators during maneuvers.

In electricity facilities and services, adopt appropriate safety signs, intended for warning and identification, in accordance with the provisions of NR-26 and NR-37, in order to meet the following situations:

- Identification of electrical circuits,
- Locking and blocking of devices and maneuvering systems and controls,
- Restricting and preventing access,
- Area delimitations,
- Signaling of circulation areas, public pathways, vehicles, and cargo handling routes,
- Signaling of energizing impediment,
- Identification of equipment or circuit prevented.

12 READING DEVICES AND MANOMETERS

For the visualization of information in gauges or other reading devices, a height range between 1040 mm and 1780 mm is recommended for the operator in standing position, while the range between 1270 mm and 1650 mm recommended for information with frequent use, requiring accurate reading and / or use in emergency situations (ABS, 2018). The equipment shall be installed in the correct reading direction, always with the reader facing the operator's side, and shall read the instrument.

TECHNICAL SPECIFICATION	Nº I-ET-3010.2Q-1400-196-P4X-001	REV A
MARLIM LESTE E SUL		sheet 51 of 57
TITLE: ERGONOMICS REQUIREMENTS FOR TOPSIDE		INTERNAL
		ESUP

13 LABORATORY

The laboratory work consists of performing analyses on the samples of oil and water received from production, from facilities, and from vessel to verify their quality and suitability.

The laboratory activity is constant and intense and is defined by the types of processes performed in the unit.

The laboratory is located in the production area and operators and technicians perform a constant flow of sample collection / transport between the various process areas and the laboratory. In most platforms, the laboratory operates 24 hours a day, in 2 shifts of 12 hours, with one or two technicians per shift.

In addition to the analyses, the technicians perform an administrative routine of filling in forms and reports and preparing a daily bulletin for controlling samples.

13.1 GENERAL CONSIDERATIONS

The following aspects shall be considered in the laboratory design:

- Types of analyzes foreseen for the laboratory of each platform – can be variable and related to the process type of the unit,
- Location of the most frequent samples collection points – to minimize the successive displacements of operators and technicians with samples,
- Necessary equipment and other needs to water and oil analysis – which will determine the distances and facilities required,

13.2 LAYOUT, FURNITURE, AND EQUIPMENT

13.2.1 LOCATION, ACCESS, AND FLOWS

The laboratory is located in the process area, taking safety issues into account, in the intermediary area between the accommodation module and the process area. It is grouped with other rooms located in the process area, such as the support room for field operators, for example.

- Safety issues shall be considered, respecting the classification of areas and seeking an arrangement between the ideal location and the less dangerous location. In the process area, there are areas with different degrees of hazard.

The laboratory shall have two accesses and consider containers and sample handling. One of these accesses shall be located in the area of analysis. Also, the doors should open in the direction of escape routes. The laboratory's height should allow proper installation of the hoods, and it is recommended to provide an expansion area of 20% for further analysis and future equipment.

13.2.2 DIMENSIONING AND LAYOUT

Due to the odors and hazard of samples and reagents, it is recommended that the laboratory be divided into two distinct areas:

- Office area – where computer equipment is located to prepare reports and fill in forms. Shall allow visualization of the analysis area.
- An analysis area – where the laboratory equipment is located correctly, and the samples are analyzed.
- In addition, it shall be provided:
 - One area for storage, delivery, and reception of samples and another area for sending samples to land
 - Adequate storage space for control samples
 - Appropriate space for storing flammable and constant-use chemical materials which may be located in the analysis area or external to the laboratory, but with easy and quick access and locked with keys.

13.2.3 FURNITURE, EQUIPMENT, DEVICES, AND FACILITIES

Provide equipment needed for each unit. The layout should minimize displacements within the laboratory. The list of laboratory equipment shall be issued in accordance with I-ET-3000.00-8222-941-PJN-001.

In addition, the following aspects should be considered in Laboratory design:

- The eyewash and emergency shower shall be installed near the main entrance of the laboratory.
- An easy-to-access cabinet with keys shall be provided to store the personal protection equipment (PPE) used in the laboratory by the technicians.
- The laboratory floor shall be nonslip, washable, chemical resistant, including oil, and low porosity, to avoid stains.
- Water taps shall be provided next to the floor for the hygiene and maintenance of the compartments.
- Industrial anti-residue door mat shall be used in the laboratory entrance to reduce the dirt in the internal environment.
- Internal doors shall have displays.

Ergonomic work analysis shall evaluate the proper size for storage of chemicals, oil drums and gas cylinders. It is necessary to size the space to store chemicals correctly.

In chemical cabinets, a locker with keys should be provided.

- The use of fire cabinets for flammable substances is recommended.

13.2.4 OFFICE

- Provide a workstation with a computer for the lab technician and space for one more network node for eventual use.
- Provide lockers, files, or shelves for documents.
- Provide separate cabinets for custody of technicians' personal belongings.
- Provide hooks for technicians' and operators' (who go to the laboratory) helmet keeping.
- Provide easy access to drinking water supply points.
- It is recommended that the office chairs have armrests and adjustments to the seat's height, backrest, and armrest.

13.2.5 ANALYSIS AREA

- For units with oil and water analysis, provide two fume hoods and at least two countertops, one for organic and the other for inorganic materials. The fume hoods should preferably be located on opposite sides next to the specific countertops.
- When dimensioning fume hoods, the design shall consider the equipment located inside, allowing the adoption of appropriate postures while using them.
- Particular attention should be paid to the heights of countertops, opening and sealing glass of the fume hood since the poor sizing can hinder equipment and glassware handling.
- Opening for the arm passage may be undertaken horizontally and/or vertically. The position and dimensions of the openings shall be adjustable.
- For horizontal openings, an adjustable height to position fume hood glass is recommended. Adjustment devices should not obstruct the area above the countertop.
- Waste disposal shall be configured according to final equipment Detail Design location and routine, including shelves for storing toxic residues and necessary drains in benches.
- Design dimensions of the exhaust system for each fume hood according to analysis requirements.
- Inside the fume hoods, two taps of kerosene and a compressed air outlet shall be provided to dry the glassware of each hood.

Countertops

- A countertop with a sink shall be provided next to each fume hood.
- Countertops should be designed with space for supporting equipment and sample collection holders.
- Countertop height shall allow working in an upright posture.

Under the countertops, cabinets (shelves and drawers) shall be provided for glassware and chemicals.

- A large number of glass containers are used. It is necessary to properly design these cabinets and the height of the shelves to accommodate all glassware, according to each project's requirements.

- The upper cabinets and fume hoods should be less deep than countertops to avoid head shock when activity occurs.

General facilities and devices:

- The design of electrical, hydraulic, and laboratory facilities should be considered during the detailing design.
- The drainage system for oil and chemicals disposal shall be independent of other water and sewage pipes throughout the laboratory, including hoods.
- Although outlets are not permitted inside the fume hoods, the outlets shall be provided in a place close to them. Many types of equipment (110 V and 220 V) are used in the laboratory. For that reason, an appropriate number of outlets should be designed near the fume hoods and distributed on the countertops.
- Telephone posts shall be provided in both laboratory spaces for internal and external calls. The purpose is to assist communication by technicians. Detail Design Ergonomics team shall verify position of telephone equipment and adjust whenever necessary.
- Geometry of benches, sinks and knuckles shall be detailed and validated with the collaboration of the Ergonomics team, according to the activities carried out on each countertop.
- In the laboratory area, office stools with support for the back and feet should be provided. Seat height and backrest adjustments shall also be foreseen.

14 ELECTRICAL SYSTEMS

Offshore platform electrical systems are composed of distribution panels, UPSs (Uninterrupted Power System, also known as NOBREAK), battery banks, and transformers. Electric panels are devices that distribute the power of the main generator set (turbo generators) to the production systems, vessel, and other facilities systems.

Ergonomic requirements for the electrical systems are described in I-ET-3010.00-5140-700-P4X-005- REQUIREMENTS FOR HUMAN ENGINEERING DESIGN FOR ELECTRICAL SYSTEMS OF OFFSHORE UNITS.

Lighting levels shall meet requirements of I-ET-3010.00-5140-700-P4X-008 – SPECIFICATION FOR LIGHTING AND ELECTRICAL SIGNALLING FOR OFFSHORE.

Specifications in this chapter also reinforce compliance with the requirements set out in NR-10, NR-26 and NR-37.

Note that some electrical systems' **areas** may not be present in the process plant of a platform, so the specifications current in this chapter can also be used to support hull detailing design.

The following general aspects shall be considered in the design of electrical systems:

- Provide space for keeping personal protection equipment (PPE) in rooms where the use of activity-specific PPE is required.
- Provide installation of an eyebolt for each smoke detector in all rooms where detectors are installed on the ceiling to assist preventive maintenance.

- Lamps positioning shall provide homogeneous lighting to allow equipment reading, operation and maintenance.
- Prioritize installation of high lifespan lighting equipment to reduce the need for maintenance and replacement.
- Lamp positioning in the process area shall consider access aspects, minimizing the need for scaffolding assembling. Light posts that are retractable, mobile or allow the easy access to the lamps installed in high position shall be considered.
- Equipment that shall use thermographic inspection shall have its accesses free of obstructions.
- Escape routes located inside electrical rooms shall be distinguished by a color (hue) that is visibly different from the surrounding flooring. The color applied to these routes shall correspond to the escape route color coding, with slight variations in saturation or brightness and have adequate signage to mitigate Human Factors risks.

14.1 PANEL ROOMS

- Access free space next to equipment shall follow I-ET-3010.00-5140-700-P4X-001 - SPECIFICATION FOR ELECTRICAL DESIGN FOR OFFSHORE UNITS.
- Insert the drawer TAG also on the back to facilitate the location of drawers for repairs.
- For digital relays, the incidence range angle cannot allow reflections on the display (e.g., height range from 1650 mm to 1900 mm).
- In the panel room, provide space for circulation and removal of circuit breakers from panels with the cart.
- The height regulation range of the tray support cart shall consider the heights of the circuit breakers of all panels in the room.
- A maximum height of 1600 mm for drawers is recommended. Drawers weighing less than 8 kg can be positioned at higher heights, with a limit of 1850 mm.
- Contacts that require future “retightening” should be positioned in easy viewing places because of electrical hazards to the maintainer.
- Electrical components exposed near the contacts in which bolts are tightened shall have insulating protection.
- In CDC panels, panels with inspection windows should be preferred to improve safety, speed, and efficiency of operations performed on the panels.
- All electrical equipment (non-removable parts) weighing more than 20 kgf shall be equipped with lifting eyebolts or equivalent device for assisting material handling
- Provide a mobile workbench to support tools, instruments and equipment used during maintenance on panels, facilitating access to these items and avoiding unnecessary displacement and movement.



Figure 36. Example of a mobile workbench, suitable for work in panel rooms

- Install conventional sockets close to equipment to assist the use of devices (such as *laptops*) during activities carried out near the panels or in longer-lasting interventions.
- Provide space for the allocation of first-aid devices, such as cardiopulmonary resuscitation device, among others.
- Detail design of arrangement for air conditioning outlets in electrical panel rooms shall provide appropriate temperature, taking into account:
 - Thermal comfort and health of operators and maintainers,
 - Operating equipment, maintaining thermal compliance with its factory specifications, providing durability and proper functioning of devices, and reducing the need for maintenance.
- Cold water pipes for HVAC shall never be routed through electrical, telecom or automation panel rooms or above panels. Water leak or condensation in pipes above panels can cause short-circuit if the liquid drips on a panel.
- Provide adjustable mobile countertop (pantographic or others) for support in electric drawers' assembly and disassembly operations.

14.2 BATTERY ROOMS

- In battery banks, battery identification and its terminals (positive and negative) should be visible to reduce the risk of accidental short-circuit in the battery terminals.
- Battery level parameters and others should be easily visible, with no obstacles to verification.
- Overlapping battery banks – For two levels, the lower level batteries shall have a free space of at least 700 mm above them. For the upper seat batteries, a stable plateau or walkway should be provided, taking into account the unit instability and the risk of the operator's fall on energized terminals. This structure should preferably be sliding not to obstruct access to the lower level when work is carried out.
- For non-sealed battery banks, adequate free space shall be provided for preventive maintenance such as:
 - Filling the batteries,



TECHNICAL SPECIFICATION	Nº I-ET-3010.2Q-1400-196-P4X-001	REV A
MARLIM LESTE E SUL		sheet 57 of 57
TITLE: ERGONOMICS REQUIREMENTS FOR TOPSIDE		INTERNAL
		ESUP

- Density measurement.
- Provide a mobile workbench for tool support during maintenance.
- Provide space and cargo handling devices for battery removal.
- Escape route shall be free, well signaled, and visible in the dark (tape or fluorescent ink) so that it guides the operator along the route even if safety lamps fail.

15 DIVING OPERATIONS

Specific areas for diving services shall be provided, and their dimensions shall meet all diving routines. Facilities shall be provided to enable such services. The aim is to assist the operation of underwater lifting by divers throughout the platform.

When using a diving basket or diving bell, those shall carry at least two divers in a comfortable position. It shall be designed with a chain or door at the entry and exit points and have handrails suitable for divers. The aim is to prevent the fall of divers.

16 VENDOR PACKAGES

All requirements of this technical specification shall be applied to all vendor packages and all skid assembled equipment.

Equipment skids shall follow the same criteria for valve and instrument positioning, as described in items 6 and 9.

Special attention shall be given to drain valves and instruments in compressor skids.